

**B R A Z E D P L A T E**

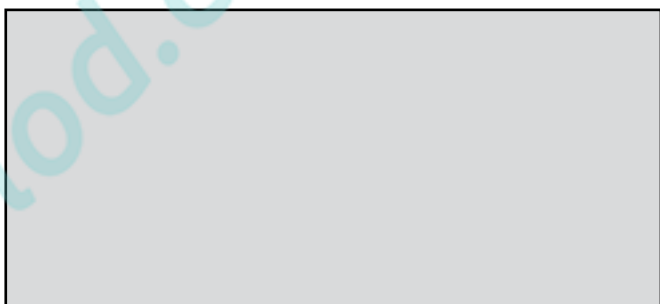

[www.photod.com.ua](http://www.photod.com.ua)

# HEAT EXCHANGERS

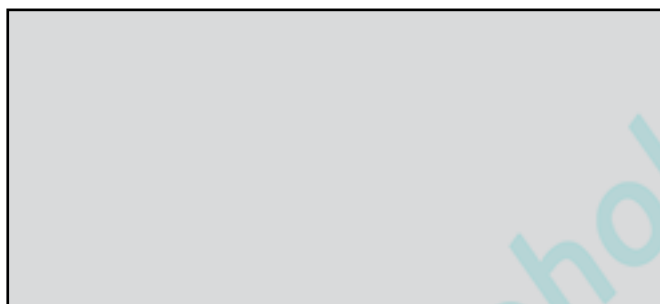

The logo for WTK, featuring a stylized 'W' composed of three curved lines to the left of the letters 'TK'.

The basic concept for a BPHE is stainless steel plates, permanently brazed together with pure copper (99,9% Cu). The plates are stacked together and form flow chambers for two or more medias. Every second plate is alternatively rotated 180° and creates flow chambers for the medias. **WTK** has developed a new type of BPHE for evaporator applications, as well as for high value systems.

The new type BPHE is smaller, cheaper and more secure than other heat exchangers.

#### EV- SYSTEM

**WTK** has invented the latest evaporator distribution system, EV-system in order to avoid bad distribution. It both breaks down the liquid drops in the refrigerant and distributes it over the entire plate package. To make "on-off" systems more precise, **WTK** has found a solution to evaporate the liquid that normally builds up in the BPHE during non-operation.

#### QUALITY

The type **WTK**'BPHE are PED-CE (Dir. 97/23 CE) certified and 100% of the BPHE are pressure and vacuum tested.

Il concetto alla base delle BPHE è l'utilizzo di piastre in acciaio inossidabile, che sono saldobrasate utilizzando rame puro (Cu 99.9%). La costruzione dello scambiatore viene eseguita sovrapponendo le piastre in acciaio ruotate di 180° ed interponendo tra di esse un foglio di rame. In questo modo si vengono a realizzare delle camere in cui i fluidi possono circolare. **WTK** ha sviluppato un nuovo tipo di evaporatore BPHE, ed un nuovo sistema per rendere più sicuri gli impianti. Il nuovo tipo di BPHE è piccolo, economico e più sicuro degli altri tipi di scambiatori.

#### EV- SYSTEM

Per evitare problemi di mal-distribuzione del refrigerante nel BPHE, **WTK** ha inventato il nuovo sistema di evaporazione (EV-System). Questo nuovo sistema fornisce una migliore miscelazione della fase liquida e vapore che caratterizza il refrigerante dopo la valvola di espansione, unita ad una distribuzione uniforme su tutti i piatti del BPHE. In questo modo **WTK** ha trovato la soluzione per evaporare il liquido che normalmente risiede nel BPHE durante il non funzionamento in sistemi "on-off".

#### QUALITA'

Tutti i modelli di BPHE prodotti da **WTK** sono certificati PED-CE (Dir. 97/23 CE) ed hanno superato i test in pressione e sotto vuoto previsti.

Die Plattenwärmeaustauscher werden aus rostfreiem Stahl mit reinem Kupfer verlötet. Die Platten aus Edelstahl werden überlappend geschweisst und um 180° gedreht. Zwischen den Platten werden Kupferbögen gelegt. Die so entstehenden Kammern, in denen später das Medium strömt werden dadurch zu 100% dicht verschlossen. **WTK** hat einen neuen Verdampfer-Typ mit einem Antileckage-System entwickelt, um bessere Sicherheit der Anlagen zu gewährleisten. Diese Baureihe von Plattenwärmeaustauschern ist wesentlich kompakter, preiswerter und betriebssicherer als bekannte Standard-Plattenwärmeaustauscher.

#### EV- SYSTEME

Um Verteilungsprobleme der Kühlflüssigkeit zu vermeiden, hat **WTK** ein neues System bei Plattenverdampfern (EV-System) entwickelt. Das System erzielt eine bessere Mischung in der Flüssigkeits- und Dampfphase des Kältemittels, das nach dem Eintritt eine gleichförmige Verteilung auf alle Platten garantiert. **WTK** hat eine Lösung gefunden, um die Flüssigkeit im Wärmeaustauscher während des "on-off" Betrieb zu verdampfen.

#### QUALITÄT

Alle Wärmeaustauschermodelle **WTK** haben das PED-CE (Dir. 97/23 CE) Qualitätszeugnis bekommen und haben die Prüfungen bestanden.

L'emploi des plaques en acier inoxydable se base sur le concept des échangeurs avec plates soudées. L'échangeur se compose de plaques en acier superposées et tournées de 180°, divisées par une feuille de cuivre. Des chambres de fluides en circulation se réalisent. **WTK** a développé un nouveau type d'évaporateur (échangeurs avec plates soudées) et un nouveau système pour assurer les installations. La nouvelle plaque est plus petite, plus économique et surtout plus sûre d'autres types d'échangeurs.

#### EV- SYSTEME

**WTK** a inventé un nouveau système d'évaporation (EV-Système) pour éviter la mauvaise distribution du réfrigérant dans l'échangeur. Ce système garantie un meilleur mélange du fluide et du vapeur qui caractérise le réfrigérant après la soupape d'expansion, liée à une distribution uniforme sur tous les plats des échangeurs.

**WTK** a trouvé la solution pour évaporer le liquide qui normalement se trouve dans l'échangeur pendant le mauvais fonctionnement dans les systèmes "on-off".

#### QUALITÉ

Tous les modèles d'échangeurs **WTK** sont certifié PED-CE (Dir. 97/23 CE) et ont dépassé les tests de pression et sous vide prévus.

**P7**      **50**      **Ev**      **S**      **/**      **-**      **P**

**P7** Type - Modello - Model - Modéle  
P7  
P15  
P30

**S** Secondary connections circuit Top Plate  
Attacchi circuito secondario Top Plate  
Sekundäre Anschlüsse Stromkreis Top Plate  
Connexions secondaires circuit Top Plate  
- = Without - Senza - Ohne - Sans  
S = Welded - A saldare - Angeschweißt - Soudé  
F = Threaded - Filettati - Betreßt - Fileté  
V = Vitalic connections - Attacco Vitalic  
Vitalic anschübe - Vitalic connexions  
T = Probe connections - Portasonda  
Prüfspitze Anschlüsse - Sonde connexions

**50** Nr. Plates - Nr. Piastre  
Nr. Plattenwärmeaustausche - Nr. de Plates  
P7 = 10 < N° < 100  
P15 = 30 < N° < 120  
P30 = 30 < N° < 200

**Ev** Primary connections circuit Top Plate  
Attacco circuito primario Top Plate  
Primäre Anschlüsse Stromkreis Top Plate  
Connexions premieres circuit Top Plate  
Ev = Evaporator welded connection  
Attacco a saldare evaporatore  
Angeschweißte Anschlüsse Verdampfer  
Connexion soudée evaporateur  
S = Welded connection  
Attacco a saldare  
Angeschweißte Anschlüsse  
Connexion soudée  
F = Threaded primary connections  
Attacco primario filettato  
Betreßte primäre Anschlüsse  
Connexion premières filettées

**-** Secondary connections circuit Bottom Plate  
Attacchi circuito secondario Bottom Plate  
Sekundäre Anschlüsse Stromkreis Bottom Plate  
Connexions secondaires circuit Bottom Plate  
- = Without - Senza - Ohne - Sans  
S = Welded - A saldare - Angeschweißt - Soudé  
F = Threaded - Filettati - Betreßt - Fileté  
V = Vitalic connections - Attacco Vitalic  
Vitalic anschübe - Vitalic connexions  
T = Probe connections - Portasonda  
Prüfspitze Anschlüsse - Sonde connexions

**P** Accessoires - Accessori - Accessoires - Accessoires  
I = Insulation - Isolamento - Stellschraube - Isolation  
P = Bolts - Prigionieri - Stiftschraube - Vis captive  
S = Feet and lifting lugs - Staffe e golfari  
Lasthacken und Standfüße - Crochet de levage  
F = Flanges - Flange - Kupplungsflansch - Brides

**NOMINAL DATA DATI NOMINALI NENNDATEN VERDAMPFER DONNES NOMINALES**

**EVAPORATOR - EVAPORATORI - VERDAMPFER - EVAPORATEUR**

Refrigerant - Refrigerante Kältemittel - Réfrigérant	<b>R22/R407C*</b>
Inlet Water temperature Temperatura entrata acqua Wassertemperatur im Einlauf Température d'entrée eau	<b>12°C</b>
Outlet Water temperature Temperatura uscita acqua Wassertemperatur im Auslauf Température de sortie eau	<b>7°C</b>
Average evaporating temperature Temperatura media di evaporazione Mittlere Verdampfungstemperatur Température d'évaporation moyenne	<b>2°C</b>
Dew evaporating temperature* Temperatura di dew* Verdampfungendetemperatur* Température de rosée*	<b>4,5°</b>

**CONDENSATOR - CONDENSATORI - VERFLUSSIGER - CONDENSATEUR**

Refrigerant - Refrigerante Kältemittel - Réfrigérant	<b>R22/R407C*</b>
Inlet water temperature Temperatura entrata acqua Wassertemperatur im Einlauf Température d'entrée eau	<b>30°C</b>
Outlet Water temperature Temperatura uscita acqua Wassertemperatur im Auslauf Température de sortie eau	<b>35°C</b>
Average condensing temperature Temperatura media di condensazione Mittlere Kondensationstemperatur Température de condensation moyenne	<b>40°C</b>
Bubble condensing temperature* Temperatura di bubble* Verflüssingendetemperatur* Température de bulbe*	<b>37,6°C</b>

**TECHNICAL DATA DATI TECNICI**

Design pressure	<b>30 bar</b>	Min / Max working temperature	<b>-160 / +200 °C</b>
Pressione di progetto	<b>30 bar</b>	Min / Max temp. di lavoro	<b>-160 / +200 °C</b>
Nennndruck	<b>30 bar</b>	Min / Max Arbeitstemperatur	<b>-160 / +200 °C</b>
Pression de project	<b>30 bar</b>	Min / Max temp. de travail	<b>-160 / +200 °C</b>

# P7 DIMENSIONS DIMENSIONI MASSE DIMENSIONS

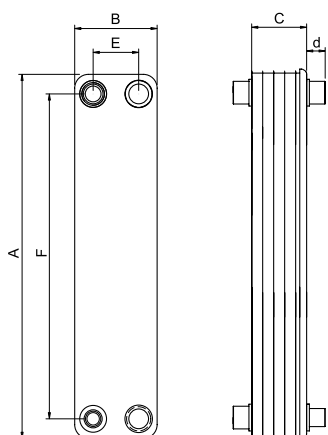

Type Modello Model Modèle	A	B	C	E	F	Vol. per channel Vol. per canale Vol. für Kanal Vol. pour canal	Heat transfer Area per plate Sup. di scambio per piastra Vermischungsfläche für Plattenwärmeaustauscher Surface de circulation pour echang. avec plates soudées	Weight Peso Gewicht Poids
P7	(mm) 526	(mm) 120	(mm) 9+2,57xN*	(mm) 66	(mm) 473	(dm <sup>3</sup> ) 0,12	(m <sup>2</sup> ) 0,07	(kg) 2,3+0,20xN*

\*Nr. Plates - Nr. Piastre - Nr. Plattenwärmeaustauscher - Nr de Plates  
d = 27 mm

## CONNECTIONS CONNESSIONI ANSCHLÜSSEN CONNEXIONS

EV

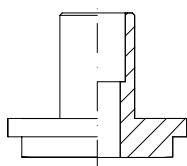

S

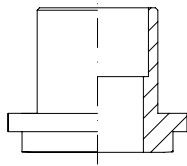

F

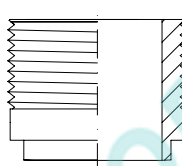

Ev System conn. Ev System conn. Anschlüsse Ev System Ev System conn.	Soldered conn. inner diam Conn. saldate diametro int. Geschweisste Anschlüsse Innerer Durchmesser Plates soudées int. Diam.	Threaded conn. male Conn. filettate Maschio Gewindebohrer Vis Male	Temp. probe female Conn. sonda temp. femmina Temp. Prüfspitze Mutterbohrer Temp. sonde
(mm)	(mm)	(gas BPS)	(gas BPS)
22,2	35,2	1"1/4	1/2"
16,2	28,7	1"	-
-	-	1"1/4 12UNF**	-

**Boldfaced std. Values - In grassetto valori Standard - Std. Werte in fetter Schrift - Std. Valeurs en caracteres gras**

\*\* = Rotalock connection - Attacco Rotalock - Anschlüsse Rotalock - Rotalock connexion

## CAPACITIES POTENZE LEISTUNGEN PUISSANCES

EVAPORATORS - EVAPORATORI - KÜHLERS - EVAPORATEURS					CONDENSERS - CONDENSATORI - KONDENSATOREN - CONDENSEURS				
Type Modello Model Modèle	Nr. Plates Nr. Piastre Nr. Plattenwärmeaust Nr. de plates	Capacity Potenza Leistung Puissance	Water flowrate Portata acqua Kälteträgerstrom Debit fluide	$\Delta p_w$	Type Modello Model Modèle	Nr. Plates Nr. Piastre Nr. Plattenwärmeaust Nr. de plates	Capacity Potenza Leistung Puissance	Water flowrate Portata acqua Kälteträgerstrom Debit fluide	$\Delta p_w$
		kW	m <sup>3</sup> /h	kPa			kW	m <sup>3</sup> /h	kPa
P7	10	5	1,0	15	P7	10	7	2	15
P7	14	8	1,4	15	P7	14	10	2	15
P7	20	11	1,9	15	P7	20	14	3	15
P7	24	13	2,3	15	P7	24	17	4	15
P7	30	17	2,9	15	P7	30	22	5	15
P7	40	22	3,8	16	P7	40	29	6	16
P7	50	28	4,7	16	P7	50	36	8	16
P7	60	33	5,7	16	P7	60	43	10	16
P7	80	43	7,4	16	P7	80	56	13	16

## ACCESSORIES ACCESSORI ACCESSORIES ACCESSOIRES

P = Bolts - Prigionieri - Stiftschraube - Vis captive

I = Insulation - Isolamento - Stellschraube - Isolation

# P15 DIMENSIONS DIMENSIONI MASSE DIMENSIONS

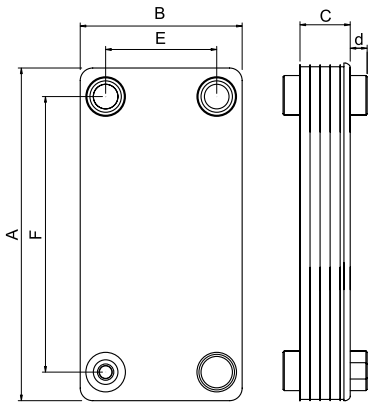

Type Modello Model Modèle	A	B	C	E	F	Vol. per channel Vol. per canale Vol. für Kanal Vol. pour canal	Heat transfer Area per plate Sup. di scambio per piastra Vermischungsfläche für Plattenwärmeaustauscher Surface de circulation pour echang. avec plates soudées	Weight Peso Gewicht Poids
P15	(mm)	(mm)	(mm)	(mm)	(mm)	(dm <sup>3</sup> )	(m <sup>2</sup> )	(kg)
	530	256	10+2,48xN*	177	439	0,27	0,15	8,1+0,41xN*

\*Nr. Plates - Nr. Piastre - Nr. Plattenwärmeaustauscher - Nr de Plates  
d = 27 mm

## CONNECTIONS CONNESSIONI ANSCHLÜSSEN CONNEXIONS

EV

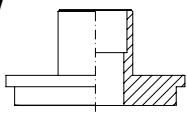

S



F

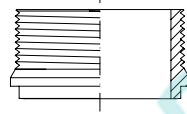

Ev System conn. Ev System conn. Anschlüsse Ev System Ev System conn.	Soldered conn. inner. diam Conn. saldate diametro int. Geschweisste Anschlüsse Innerer Durchmesser Plates soudées int. Diam.	Threaded conn. male Conn. filettate Maschio Gewindebohrer Vis Male	Temp. probe female Conn. sonda temp. femmina Temp. Prüfspitze Mutterbohrer Temp. sonde
(mm)	(mm)	(gas BPS)	(gas BPS)
22,2	54,2	2"	1/2"
28,7	42,4	-	-

Boldfaced std. Values - In grassetto valori Standard - Std. Werte in fetter Schrift - Std. Valeurs en caracteres gras

## CAPACITIES POTENZE LEISTUNGEN PUISSANCES

EVAPORATORS - EVAPORATORI - KÜHLERS - EVAPORATEURS					CONDENSERS - CONDENSATORI - KONDENSATOREN - CONDENSEURS				
Type Modello Model Modèle	Nr. Plates Nr. Piastre Nr. Plattenwärmeaust Nr. de plates	Capacity Potenza Leistung Puissance	Water flowrate Portata acqua Kälteträgerstrom Debit fluide	Δpw	Type Modello Model Modèle	Nr. Plates Nr. Piastre Nr. Plattenwärmeaust Nr. de plates	Capacity Potenza Leistung Puissance	Water flowrate Portata acqua Kälteträgerstrom Debit fluide	Δpw
		kW	m <sup>3</sup> /h	kPa			kW	m <sup>3</sup> /h	kPa
P15	30	29	5,0	12	P15	30	38	6,5	20
P15	40	39	6,6	13	P15	40	50	8,6	22
P15	50	48	8,2	13	P15	50	62	10,7	22
P15	60	57	9,8	13	P15	60	74	12,8	22
P15	80	75	12,9	14	P15	80	98	16,8	24
P15	100	93	16,0	14	P15	100	121	20,8	24

## ACCESSORIES ACCESSORI ACCESSORIES ACCESSOIRES

P = Bolts - Prigionieri - Stiftschraube - Vis captive  
I = Insulation - Isolamento - Stellschraube - Isolation  
S = Feet and lifting lugs - Staffe e Golfari - Lasthacken and Standfüße - Crochet de levage

# P30 DIMENSIONS DIMENSIONI MASSE DIMENSIONS

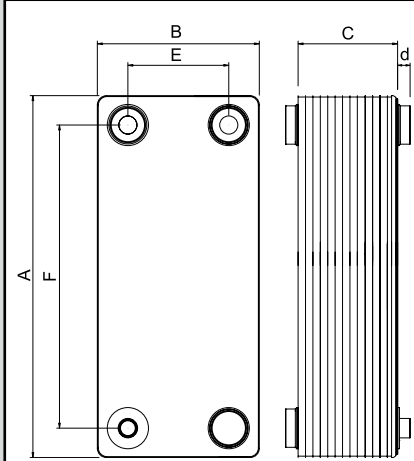

Type Modello Model Modèle	A	B	C	E	F	Vol. per channel Vol. per canale Vol. für Kanal Vol. pour canal	Heat transfer Area per plate Sup. di scambio per piastra Vermischungsfläche für Plattenwärmeaustauscher Surface de circulation pour echang. avec plates soudées	Weight Peso Gewicht Poids
P30	(mm)	(mm)	(mm)	(mm)	(mm)	(dm <sup>3</sup> )	(m <sup>2</sup> )	(kg)
	782	350	11+2,90xN*	220	655	0,53	0,3	16,1+0,86xN*

\*Nr. Plates - Nr. Piastre - Nr. Plattenwärmeaustauscher - Nr de Plates  
d = 27 mm v = 54 mm (viciaulick)

## CONNECTIONS CONNESSIONI ANSCHLÜSSEN CONNEXIONS

EV

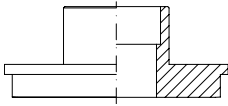

S

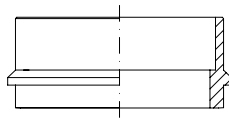

F

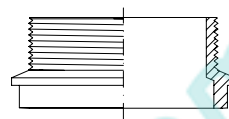

Ev System conn. Ev System conn. Anschlüsse Ev System Ev System conn.	Soldered conn. inner. diam Conn. saldate diametro int. Geschweisste Anschlüsse Innerer Durchmesser Plates soudées int. Diam.	Threaded conn. male Conn. filettate Maschio Gewindebohrer Vis Male	Temp. probe female Conn. sonda temp. femmina Temp. Prufspitze Mutterbohrer Temp. sonda
(mm)	(mm)	(gas BPS)	(gas BPS)
35,2	76,4	2" 1/2	1/2"
-	67,1	-	-
-	88,9	-	-

Boldfaced std. Values - In grassetto valori Standard - Std. Werte in fetter Schrift - Std. Valeurs en caracteres gras

## CAPACITIES POTENZE LEISTUNGEN PUISSANCES

EVAPORATORS - EVAPORATORI - KÜHLERS - EVAPORATEURS					CONDENSERS - CONDENSATORI - KONDENSATOREN - CONDENSEURS				
Type Modello Model Modèle	Nr. Plates Nr. Piastre Nr. Plattenwärmeaust Nr. de plates	Capacity Potenza Leistung Puissance kW	Water flowrate Portata acqua Kälteträgerstrom Debit fluide m <sup>3</sup> /h	Δpw kPa	Type Modello Model Modèle	Nr. Plates Nr. Piastre Nr. Plattenwärmeaust Nr. de plates	Capacity Potenza Leistung Puissance kW	Water flowrate Portata acqua Kälteträgerstrom Debit fluide m <sup>3</sup> /h	Δpw kPa
P30	40	80	13	10	P30	40	104	17	17
P30	50	100	16	10	P30	50	130	21	17
P30	60	118	19	10	P30	60	153	25	17
P30	80	156	25	11	P30	80	203	33	19
P30	100	192	31	16	P30	100	250	40	27
P30	120	230	37	16	P30	120	299	48	27
P30	150	285	46	16	P30	150	371	60	27
P30	200	375	59	16	P30	200	488	77	27

## ACCESSORIES ACCESSORI ACCESSORIES ACCESSOIRES

S = Feet and lifting lugs - Staffe e Golfari - Lasthacken und Standfüße - Crochet de levage

I = Insulation - Isolamento - Stellschraube - Isolation

F = Flanged Connections\* - Flange a corredo\* - Kupplungsflansch\* - Brides\*

\* = with threaded connections - accoppiate ad attacchi filettati - mit betressten Anschlüssen - avec connexions filetéés

# BRAZED PLATE HEAT EXCHANGER P12

As always oriented towards researching innovative solutions capable of meeting the ever changing needs of the cooling industry, WTK introduces its new range of brazed plate heat exchangers. The new P12 is a single circuit brazed plate, designed to provide an high-tech heat exchanger for chiller manufacturers to be used in AC and process cooling applications. P12 can work both as an evaporator and as a condenser with the most commonly used refrigerants: it features an extremely compact design and high capacity per unit (kW/plate) and is therefore the ideal heat exchanger for modern cooling systems where higher capacities and evermore compact designs are now needed.

WTK da sempre orientata alla ricerca di soluzioni innovative capaci di soddisfare al meglio le mutevoli esigenze della tecnica del freddo, presenta la sua rinnovata gamma di scambiatori di calore a piastre saldobrasate. La nuova P12 è una piastra monocircolo che è stata progettata per fornire ai costruttori di chiller per applicazioni in A.C. e raffreddamento di processo un moderno scambiatore evaporante o condensante, ottimizzato per i fluidi frigorigeni di comune impiego. L'estrema compattezza, unita ad una elevata resa frigorifera unitaria (kw/piastra), fanno di P12 lo scambiatore ideale per l'impiego in macchine frigorifere di moderna concezione, chiamate ad esprimere potenze sempre più elevate in ingombri contenuti.

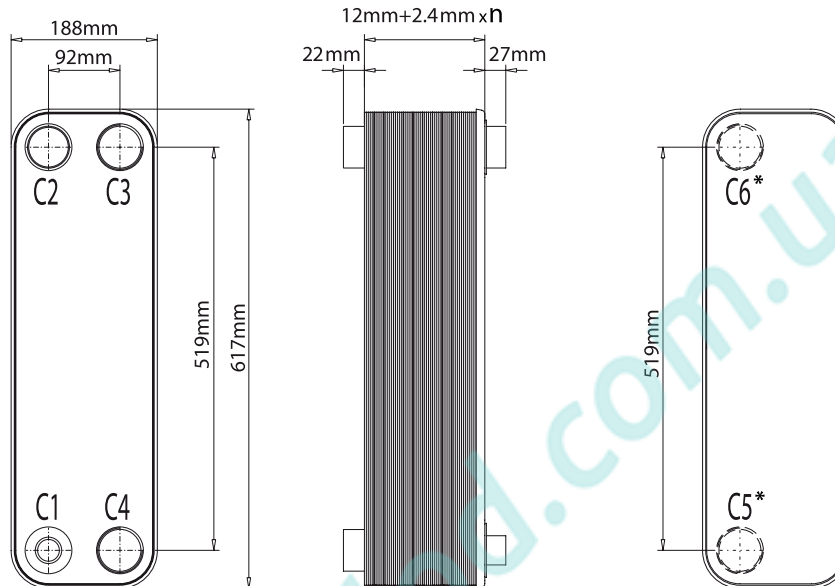

## STANDARD CONNECTIONS / CONNESSIONI STANDARD

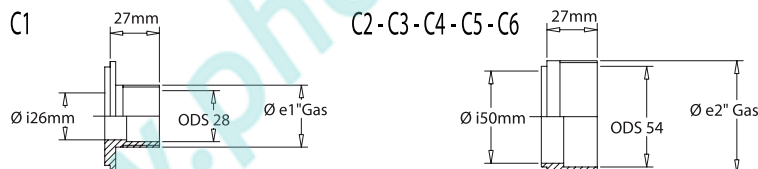

## TECHNICAL DATA - DATI TECNICI

Capacity range (standard nominal conditions) Gamma potenze (condizioni nominali standard)	40 - 230 kW	136600 - 785450 btu/h
Max/Min working temperatures Temperatura di lavoro min/max	-160°C / +200°C	-256°F / 392°F
Max fluid flow rate Portata fluido massima	33 m <sup>3</sup> /h	145 usg/min.
Max number of plates "n" Numero massimo di piastre "n"	200	200
Single circuit volume Volume per circuito	0,20 x (n/2-1) dm <sup>3</sup>	0,05 x (n/2-1) gal.
Weight Peso	7,8+(0,38 x n) kg	17,1+(0,83 x n) lb
Standard refrigerant connections size C1 - C2 Dimensione connessioni standard refrigerante C1 - C2	28 mm - 54 mm ODS	1,095 inch - 2,13 inch ODS
Standard water connections size C3 - C4 Dimensione connessioni standard acqua C3 - C4	2" BSPT	2" BSPT
C5*, C6* = connections available only on request C5*, C6* = connessioni disponibili solo su richiesta	2" BSPT	2" BSPT
Other connections available on request Connessioni differenti disponibili su richiesta		