



Catalogo tecnico
Technical catalog

www.pholod.com.ua

denaline
refrigeration and air conditioning equipment

**Denaline
Refrigeration and air
conditioning equipment**



**Esperienza qualità
e innovazione
nel rispetto
dell'ambiente**
**The experience,
quality and innovation
while being kind
to the environment**

30 Anni di esperienza, 8.500 mq di superficie coperta, più di 1 milione di rubinetti e oltre 300.000 ricevitori prodotti all'anno: denaline ha i numeri, il know-how e la tecnologia di un vero leader.

Realizziamo a Pordenone, nel nord est d'italia, i nostri prodotti controllati, collaudati e distribuiti in tutto il mondo.

L'ottimo rapporto qualità/servizio/prezzo, derivato da scelte responsabili e attente, ci ha permesso di conquistare mercati importanti, per un fatturato estero che raggiunge l'80% del totale.

La nostra azienda è leader in Europa e come tale riconosciuta nel suo mercato di riferimento, perché attenta alla qualità, alla sicurezza e

all'ambiente. I nostri investimenti nella tecnologia e nella formazione, ci hanno consentito di mettere a punto un ciclo produttivo all'avanguardia, con gestione completamente integrata.

Disponiamo di impianti di collaudo ad elio, di un impianto di galvanostegia, di vari centri di lavoro a controllo numerico, di un impianto di verniciatura alle polveri, di forni di brasatura, di impianti di saldatura e molto altro ancora. Ci impegniamo nella produzione di soluzioni per sistemi che richiedono elevate prestazioni e lunghi cicli di vita, senza trascurare lo sviluppo di componenti che utilizzano refrigeranti naturali, ecocompatibili ed a basso impatto ambientale.

30 years of experience, 8,500 sq m of floor space, over 1 million valves and over 300,000 vessels manufactured each year: DENALINE has the figures, know-how and technology you'd expect from a true leader.

Based in Pordenone, in Italy's Northeast, this is where we manufacture, quality-control and test our products, which are then distributed worldwide. The excellent quality/service/price ratio - which comes with responsible, considered choices - has allowed us to gain a strong foothold in important markets, with foreign sales accounting for 80% of our total.

We are a leading name in Europe and recognized as such in our target market by virtue of our focus on quality, safety and the environment.

Our investments in technology and training have allowed us to develop a cutting-edge production cycle, featuring fully integrated management.

We have helium testing systems, an electroplating system, various NC machining centres, a powder coating plant, brazing furnaces, welding systems, and the list goes on...

We are committed to producing solutions for systems that demand high performance and lengthy life cycles, while also developing components that use natural environmentally friendly refrigerants with little environmental impact.



**Organizzazione
efficiente e continui
investimenti in nuove
tecnologie**
Efficient organization
and ongoing
investments
in new technologies

Attraverso un efficiente e attivo servizio di ricerca e sviluppo, offriamo una produzione caratterizzata da originalità, esclusività ed efficacia, per una gamma di applicazioni quanto mai ampia: refrigerazione industriale e commerciale, trasporti a temperatura controllata, applicazioni ferroviarie e marine, impianti di condizionamento, sistemi progettati per settori specifici. Nel corso degli anni, abbiamo messo a punto all'interno dell'azienda molti prodotti esclusivi e coperti da brevetto.

Produciamo ricevitori di liquido, verticali e orizzontali, particolari per ricevitori, rubinetti a saldare, separatori di liquido, silenzianti, rubinetti di vari tipi in acciaio e ghisa, attacchi, raccordi, indicatori di livello e umidità, filtri disidratatori ecc., tutti garantiti e certificati per la massima

sicurezza e qualità e idonei anche ai refrigeranti ecocompatibili (anidride carbonica – ciclo subcritico e transcritico, ammoniaca e idrocarburi).

Our efficient R&D department is always busy working on highly effective products that offer original, exclusive features, coming up with solutions for a whole host of different applications: industrial and commercial refrigeration, temperature-controlled transport, railway and marine applications, air-conditioning systems, and systems designed for specific sectors. Over the years, we have developed many exclusive, patent-protected products in-house. We manufacture both vertical and horizontal liquid vessels, vessel parts, weld-on valves, liquid separators, silencers, stainless steel and cast iron valves of various kinds, fittings, unions, level and moisture indicators, drying filters, etc.. All parts come with the highest levels of quality and safety guaranteed and certified and are also compatible with environmentally friendly refrigerants (carbon dioxide - subcritical and transcritical cycles - ammonia and hydrocarbons).

Stiamo altresì estendendo la nostra gamma con una serie di nuovi prodotti, realizzati in alluminio, acciai speciali e rame, che utilizzano refrigeranti sia artificiali che naturali, quali: separatori d'olio fino a 450lt, valvole by-pass, valvole di sicurezza, valvole a tre vie, indicatori di liquido/gas per sensori elettronici, ricevitori in alluminio, valvole con attacchi in rame e collettori in rame.

We are also extending our range with a series of new products, made from aluminium, special steels and copper, that use both artificial and natural refrigerants, such as: oil separators up to 450l, bypass valves, safety valves, 3-way valves, liquid/gas indicators for electronic sensors, aluminium vessels, valves with copper fittings and copper manifolds.

**Ricerca
all'avanguardia per
soluzioni innovative
e custom design**
Cutting-edge
research for
innovative solutions
and custom design

Oltre alla produzione corrente, offriamo la creazione di prototipi su specifiche richieste del cliente e in tempi rapidi; l'elevato livello di servizio/qualità è garantito non solo dalle risorse interne qualificate e continuamente aggiornate, ma anche da fornitori ormai storici e da società esterne che realizzano le simulazioni e le analisi dei nostri prodotti.

Mettiamo a disposizione uno staff di tecnici esperti e altamente qualificati, in grado di concepire le soluzioni più idonee, con un vero servizio personalizzato e professionale: come un vero e proprio ufficio tecnico del cliente, presso di noi.

In addition to our current range, we can give you a fast turnaround on prototypes tailored to your specific requirements. The high level of service/quality is guaranteed not only by our own qualified human resources who receive regular retraining, but also by our long-standing suppliers and independent companies running simulations and analyses on our products.

Our team of highly qualified expert engineers is here to help, coming up with solutions that best cater to your needs as part of a truly bespoke professional service: like having your very own technical department at our place.



La qualità certificata di un'azienda italiana protagonista nel mondo
The certified quality of a world-leading italian company

La rispondenza alle principali normative internazionali, è un requisito fondamentale per un'azienda ai primi posti nel mercato mondiale. I nostri prodotti sono in conformità con le norme UNI EN ISO 9001:2008, con la direttiva europea 97/23/EC (Pressure Equipment Directive) e con gli Standards UL. Sempre all'avanguardia, ci trovate alle fiere e manifestazioni del settore in Italia e all'estero (Mostra Convegno Expoconfort, Chillventa, China Refrigeration) con la più avanzata tecnologia italiana e la nostra passione sempreverde per l'eccellenza, in ogni aspetto del nostro lavoro.

Being in line with the main international standards is an essential requirement for a company ranking amongst the top players in the world market. Our products meet the requirements of standard UNI EN ISO 9001:2008, European Directive 97/23/EC (Pressure Equipment Directive) and UL standards. Consistently at the cutting edge, we take part in trade shows and exhibitions in Italy and abroad (Mostra Convegno Expocomfort, Chillventa, China Refrigeration), showcasing the most advanced Italian technology and our evergreen passion for excellence in every aspect of our work.



Certificate of Quality Management System UNI EN ISO 9001



CE
Organismo Notificato n. 1131

CERTIFICATO

Sorveglianza della Verifica Finale

In accordo alla Direttiva 97/23/CE
Certificato No.: 05/164-VF2280 Rev.2
Categoria: II

Nome e Indirizzo del Fabbricante: DENALINE S.p.A.
Via Segaluzza, 11B
33170 - Pordenone (PN)

A seguito degli accertamenti effettuati, il Fabbricante è autorizzato ad apporre, in corrispondenza della Marcatura CE, il numero identificativo sottoriportato su ciascuna attrezzatura a pressione prodotta:

CE 1131

Procedura in accordo alla Direttiva 97/23/CE: Controllo di fabbricazione interno e sorveglianza della verifica finale (Modulo A1)

Rapporto di Audit No: 10/038-RA004 del 06/02/2012

Descrizione delle attrezzature a pressione: Ricevitori e Separatori di liquido (Fluido tipo 2)
Dis. 7000.011.0 rev.2
Dis. 7000.012.0 rev.2
Dis. 7000.020.0 rev.3
Dis. 7000.021.0 rev.3
Dis. 7000.022.0 rev.3

Luogo di produzione: c/o DENA LINE S.p.A.
Via Segaluzza, 11B
33170 - Pordenone (PN)

CONSORZIO EUROPEO CERTIFICAZIONE

L'ORGANO DELIBERANTE

Legnano, 6 febbraio 2012

Il Direttore Tecnico
(A. FUGAZZI)

Il Direttore Generale
(M. SCASSO)

CEC - CONSORZIO EUROPEO CERTIFICAZIONE

Sede Legale e Ufficio: Via Piaccave, 45- 20025 LEGNANO (MI) Italy - tel. (+39) 0331 - 442266- fax (+39) 0331- 440054
www.consortiocec.com - info@consortiocec.com - C.F. e P. IVA 1307180155 - Tribunale di Milano 023202020 - C.C.I.A.A. 1632104



CE
Organismo Notificato n. 1131

CERTIFICATO

Sorveglianza della Verifica Finale

In accordo alla Direttiva 97/23/CE
Certificato No.: 0
Categoria: II

Nome e Indirizzo del Fabbricante: DENA LINE S.p.A.
Via Segaluzza, 11B
33170 - Pordenone (PN)

A seguito degli accertamenti effettuati, il Fabbricante è autorizzato ad apporre, in corrispondenza della Marcatura CE, il numero identificativo sottoriportato su ciascuna attrezzatura a pressione prodotta:

CE 1131

Procedura in accordo alla Direttiva 97/23/CE: Controllo di fabbricazione interno e sorveglianza della verifica finale (Modulo A1)

Rapporto di Audit No: 10/038-RA005 del 06/02/2012

Descrizione delle attrezzature a pressione: Ricevitori per fluidi di tipo 1
Dis. 7000.025.0 rev.0

Luogo di produzione: c/o DENA LINE S.p.A.
Via Segaluzza, 11B
33170 - Pordenone (PN)

CONSORZIO EUROPEO CERTIFICAZIONE

L'ORGANO DELIBERANTE

Legnano, 6 febbraio 2012

Il Direttore Tecnico
(A. FUGAZZI)

Il Direttore Generale
(M. SCASSO)

CEC - CONSORZIO EUROPEO CERTIFICAZIONE

Sede Legale e Ufficio: Via Piaccave, 45- 20025 LEGNANO (MI) Italy - tel. (+39) 0331 - 442266- fax (+39) 0331- 440054
www.consortiocec.com - info@consortiocec.com - C.F. e P. IVA 1307180155 - Tribunale di Milano 023202020 - C.C.I.A.A. 1632104

Denaline (II^a cat Fluido 2)

Denaline (II^a cat Fluido 1)



CE
Organismo Notificato n. 1131

CERTIFICATE

Quality-System
Sistema qualità
for Pressure Equipment Manufacturer according to Directive 97/23/EC
per attrezzature a pressione in accordo alla direttiva 97/23/CE
Certificato No.: 05/164- QP2282 Rev. 3

Name and Address of Manufacturer: DENALINE S.p.A.
Nome e Indirizzo del Fabbricante: Via Segaluzza, 11/B
33170 Pordenone - ITALY

It is hereby certified, that the manufacturer had introduced and applies a quality system according to Directive 97/23/EC. The manufacturer is authorised, to affix the following sign to those equipment he produced in the range of validity of this QA-system:

Si certifica che il Fabbricante ha introdotto ed applica un Sistema di Qualità in accordo con la direttiva 97/23/CE. Il Fabbricante è autorizzato ad apporre il numero sottoriportato sulle attrezzature prodotte in accordo e nei limiti della validità del suo Sistema di Qualità.

CE 1131

Audited according to Directive 97/23/EG: QA-system (module D)
Procedura in accordo alla Direttiva 97/23/CE: Garanzia Qualità Produzione (Modulo D)
Report No: 12/023-RA001 del 28/11/2012
Rapporto No:
Validity: 06/11/2015
Validità:

Scope: Vessels (Recipients)
Descrizione delle/le attrezzatura/e a Module B rilasciati da NO.BD n. 0044 (RWTUV)
pressione: 04 202 1 13 | 04 00304/00305/00306/00307/00308/00309

Production facility: DENALINE S.p.A.
Luogo di costruzione: Via Segaluzza, 11/B
33170 Pordenone - ITALY

Legnano, 06 Settembre 2013



PRD n° 1148 ESP n° 6718
Membro degli Accordi di Mutuo Riconoscimento EA, IAF e ILAC
Signatory of EA, IAF and ILAC Mutual Recognition Agreement

CONSORZIO EUROPEO CERTIFICAZIONE
L'ORGANO DELIBERANTE

Il Direttore Tecnico
(A. FUGAZZI)

Il Direttore Generale
(L. TIMOSSO)

CEC - CONSORZIO EUROPEO CERTIFICAZIONE S.C.A.R.L.
Sede Legale e Uffici: Via Pisacane, 46- 20025 LEGNANO (MI) Italy - tel. (+39) 0331 - 442266- fax (+39) 0331- 440054
www.consortiocec.com - info@consortiocec.com - C.F. e P. IVA 13073180155 - Tribunale di Milano 812330285 - C.C.I.A.A. 1813104

Denaline Modulo D

CERTIFICATE OF COMPLIANCE

Certificate Number 20210713 - SA12579
Report Reference SA12579 - 20021018
Issue Date 2012-JULY-13

Issued to: DENA LINE SPA
VIA SEGALUZZA 11/B
33170 PORDENONE, PN ITALY

This is to certify that representative samples of Valves, Refrigerant Refrigerant Shutoff Valves, Models E19, E22, Q20, Q22, Q30, Q35, Q45.

Have been investigated by UL in accordance with the Standard(s) indicated on this Certificate.

Standard(s) for Safety: ANSI/UL 207, "Refrigerant-Containing Components and Accessories, Nonelectrical" and CSA-C22.2 No. 140.3, "Refrigerant-Containing Components for Use in Electrical Equipment."

Additional Information: See the UL Online Certifications Directory at www.ul.com/database for additional information

Only those products bearing the UL Listing Mark for the US and Canada should be considered as being covered by UL's Listing and Follow-Up Service meeting the appropriate requirements for US and Canada.

The UL Listing Mark for the US and Canada generally includes: the UL in a circle symbol with "C" and "US" identifiers: "C" the word "LISTED"; a control number (may be alphanumeric) assigned by UL; and the product category name (product identifier) as indicated in the appropriate UL Directory.

Look for the UL Listing Mark on the product.

William R. Conroy, Director, North American Certification Programs

M. 1115

Any information and documentation involving UL Mark schemes are provided on behalf of UL (L.L.C.) or any authorized licensee of UL. For questions, please contact a local UL Customer Service Representative at www.ul.com/customer



Shutoff Valves Certificate Iron

CERTIFICATE OF COMPLIANCE

Certificate Number 20210713 – SA12579
Report Reference SA12579 - 20040217
Issue Date 2012-JULY-13

Issued to: DENA LINE SPA
VIA SEGALUZZA 11/B
33170 PORDENONE, PN ITALY

This is to certify that representative samples of Valves, Refrigerant Refrigerant Shutoff Valves, Models DN40, DN50, DN70, DN94.

Have been investigated by UL in accordance with the Standard(s) indicated on this Certificate.

Standard(s) for Safety: ANSI/UL 207, "Refrigerant-Containing Components and Accessories, Nonelectrical" and CSA-C22.2 No. 140.3, "Refrigerant-Containing Components for Use in Electrical Equipment."

Additional Information: See the UL Online Certifications Directory at www.ul.com/database for additional information

Only those products bearing the UL Listing Mark for the US and Canada should be considered as being covered by UL's Listing and Follow-Up Service meeting the appropriate requirements for US and Canada.

The UL Listing Mark for the US and Canada generally includes: the UL in a circle symbol with "C" and "US" identifiers;  the word "LISTED"; a control number (may be alphanumeric) assigned by UL; and the product category name (product identifier) as indicated in the appropriate UL Directory.

Look for the UL Listing Mark on the product.

William K. Conroy, Director, North American Certification Programs
SA 110

Any information and documentation involving UL Mark services are provided on behalf of UL, LLC (UL) or any authorized licensee of UL. For questions, please contact a local UL Customer Service Representative at www.ul.com/customer-service.



Certificate of Compliance

Certificate Number 20081006-SA12829
Report Reference SA12829, 2008 October 3
Issue Date 2008 October 8

Page 1 of 1



Issued to: DENA LINE SPA
VIA SEGALUZZA 11/B
33170 PORDENONE PN ITALY

This is to certify that representative samples of

LIQUID INDICATORS, REFRIGERANT

Model: Refrigerant oil and moisture sight glasses, series DL, may be followed by O or U, followed by 15, 18, 19, 22, 28 or 40, may be followed by A.

Have been investigated by Underwriters Laboratories Inc.® in accordance with the Standard(s) indicated on this Certificate.

Standard(s) for Safety: UL 207 - Refrigerant-Containing Components and Accessories, Nonelectrical
CSA/CAN C22.2 No. 140.3 - Refrigerant-Containing Components for Use in Electrical Equipment

Additional Information: Rating - Design pressure 1160 psig

Only those products bearing the UL Listing Mark for the US and Canada should be considered as being covered by UL's Listing and Follow-Up Service meeting the appropriate requirements for US and Canada.

The UL Listing Mark for the US and Canada generally includes: the UL in a circle symbol with "C" and "US" identifiers;  the word "LISTED"; a control number (may be alphanumeric) assigned by UL; and the product category name (product identifier) as indicated in the appropriate UL Directory.

Look for the UL Listing Mark on the product

Issued by
David Marewa, Engineer
Underwriters Laboratories Inc.

Reviewed by
Giulio Bonarri, CAS Manager I
Underwriters Laboratories Inc.

Certificate of Compliance

Certificate Number: 20081000-SA328298
 Report Reference: SA32829, 2008 October 4
 Issue Date: 2008 October 8

Page 1 of 1



Issued to: **DENA LINE SPA**
 VIA SEGALUZZA 11/B
 33170 PORDENONE PN ITALY

This is to certify that
 representative samples of

LIQUID INDICATORS, REFRIGERANT

Model: Refrigeration liquid indicators, Series DL followed by L or M, followed by F or S, followed by 06, 07, 08, 09, 10, 12, 13, 14, 16, 18, 19, 22, 23, 28, 29, 34, 38 or 58, followed by M, F or S, followed by 06, 07, 08, 09, 10, 12, 13, 14, 16, 18, 19, 22, 23, 28, 29, 34, 38 or 58.

Have been investigated by Underwriters Laboratories Inc.® in accordance with the Standard(s) indicated on this Certificate.

Standard(s) for Safety:

UL 207 - Refrigerant-Containing Components and Accessories, Nonelectrical
 CSA/CAN C22.2 No. 140.3 - Refrigerant-Containing Components for Use in Electrical Equipment

Additional Information:

Rating - Design pressure 1160 psig

Only those products bearing the UL Listing Mark for the US and Canada should be considered as being covered by UL's Listing and Follow-Up Service meeting the appropriate requirements for US and Canada.

The UL Listing Mark for the US and Canada generally includes: the UL in a circle symbol with "C" and "US" identifiers; the word "LISTED"; a control number (may be alphanumeric) assigned by UL; and the product category name (product identifier) as indicated in the appropriate UL Directory.

Look for the UL Listing Mark on the product

Issued by:
 Davide Marzoni, Engineer
 Underwriters Laboratories Inc.

Reviewed by:
 Guido Bonardi, CAS Manager
 Underwriters Laboratories Inc.

Indice Index

RICEVITORI DI LIQUIDO LIQUID RECEIVERS

Verticali Tipo AV 45 bar Vertical receivers Type AV 45 bar	p. 1
Verticali Standard Tipo DNL 45 bar Vertical receivers Type DNL 45 bar	p. 2
Orizzontali Tipo AH 45 bar Horizontal receivers Type AH 45 bar	p. 3
Verticali Tipo BV 45 bar Vertical receivers Type BV 45 bar	p. 4
Orizzontali Tipo BH 45 bar Horizontal receivers Type BH 45 bar	p. 5
Verticali Tipo CV 45 bar Vertical receivers Type CV 45 bar	p. 6
Standard Tipo TKV 33 bar Vertical receivers Type TKV 33 bar	p. 7
Orizzontali Tipo CH 45 bar Horizontal receivers Type CH 45 bar	p. 8
Orizzontali Tipo TKH 33 bar Horizontal receivers Type TKH 33 bar	p. 9
Verticali Tipo DLV -CO₂ (R744) 130 bar Vertical receivers Type DLV -CO ₂ (R744) 130 bar	p. 10
Orizzontali Tipo DLH-CO₂ (R744) 130 bar Horizontal receivers Type DLH -CO ₂ (R744) 130 bar	p. 11

COMPONENTI PER RICEVITORI COMPONENTS FOR RECEIVERS

Gomiti-Indicatori di livello/umidità brevettati Elbow connections-moisture sight glasses patented	p. 12
Attacchi ODS-SAE-NPT-O-Ring-Rotalock-Rubinetti a saldare ODS-SAE-NPT-O-Ring connections-soldering valves	p. 13

SEPARATORI DI LIQUIDO SUCTION ACCUMULATORS

Da calotte 34 bar From caps 34 bar	p. 15
Da tubo vol. max. 320lt 45 bar From tube max. capacity 320lt 45 bar	p. 16
Con scambiatore di calore 45 bar With tube condenser 45 bar	p. 17
Per CO₂ (R744) 130 bar For CO ₂ (R744) 130 bar	p. 18

RICEVITORI D'OLIO OIL RECEIVERS

Volumi da 5,7lt a 30lt 45 bar Capacity from 5,7lt up to 30lt 45 bar	p. 19
Da tubo vol. max. 30lt per CO₂ (R744) 130 bar From tube max. capacity 30lt for CO ₂ (R744) 130 bar	p. 20

SILENZIATORI MUFFLERS

Da calotte 45 bar From caps 45 bar	p. 21
Da tubo per CO₂ (R744) 130 bar From tube for CO ₂ (R744) 130 bar	p. 21

SEPARATORI D'OLIO CON RISERVA D'OLIO OIL SEPARATORS WITH OIL RESERVATION

Vol. 0,4÷1,7lt portata volumetrica compressore max. 14m³/h Capacity 0,4÷1,7lt approx. compressor displacement 14m ³ /h	p. 22
Vol. 3,4÷22,0lt portata volumetrica compressore da 10 a 110 m³/h Capacity 3,4÷22,0lt approx. compressor displacement from 10 up to 110m ³ /h	p. 23
Vol. 35÷89lt portata volumetrica compressore da 75 a 300 m³/h Capacity 35÷89lt approx. compressor displacement from 75 up to 300 m ³ /h	p. 24
Vol. 50÷310lt portata volumetrica compressore da 120 a 700 m³/h Capacity 50÷310lt approx. compressor displacement from 120 up to 700 m ³ /h	p. 25
Vol. 2,8÷12,7lt portata volumetrica compressore da 8 a 60 m³/h per CO₂ (R744) Capacity 2,8÷12,7lt approx. compressor displacement from 8 up to 60m ³ /h	p. 26

FILTRI DISIDRATATORI A SETACCIO MOLECOLARE MOLECULAR SIEVE FILTER DRIERS

Con attacchi SAE With SAE connections	p. 27
Con attacchi ODS With ODS connections	p. 28
Con cartuccia ricambiabile Desiccant replaceable cartridge filters	p. 29
Con riserva di liquido With liquid reserve	p. 30

FILTRI MECCANICI MECHANICAL FILTERS

A cartuccia filtrante ricambiabile With replaceable cartridge	p. 31
A filtro non ricambiabile Grid filter non rechargeable	p. 32

RUBINETTI PER I FLUIDI DEL GRUPPO I E II DELLA PED VALVES FOR REFRIGERANT FLUIDS GROUP I AND II PED

Informazioni generali General information	p. 33
Rubinetti rotalock con attacco flare (SAE) Rotalock valve with flare connections	p. 34
Rubinetti rotalock con attacco a saldare (ODS) Rotalock valve with solder connections	p. 36
Rubinetti rotalock con attacco ODS in rame Rotalock valve with copper outlet ODS	p. 39
Rubinetti ad angolo a saldare Angle valves to sold	p. 41
Rubinetti ad angolo per CO₂ (R744) Angle valves for CO ₂ (R744)	p. 44
Rubinetti flangiati con attacco flare (SAE) Flanged valves with outlet flare connections	p. 45
Rubinetti flangiati con attacco ODS Flanged valves with outlet ODS	p. 47
Rubinetti flangiati con attacco ODS in rame Flanged valves with copper outlet ODS	p. 50
Rubinetti a flangia per CO₂ (R744) Flanged valves for CO ₂ (R744)	p. 53
Rubinetti orizzontali rotalock con attacco O-Ring Horizontal rotalock valves with O-Ring outlet	p. 54

Rubinetti per basamenti Valves for panels	p. 55
Rubinetti verticali con staffa Vertical valves with bracket	p. 56
Rubinetti con base filettata e ODS in rame Threading vertical valves with copper ODS	p. 61
Rubinetti con base filettata e ingresso/uscita o SAE o ODS Threading vertical valves with inlet-outlet or ODS or SAE	p. 62
Rubinetti verticali con attacco rotalock in ingresso Vertical valves with rotalock inlet	p. 64
Rubinetti verticali esagonali con ODS in rame Hexagonal valves with copper ODS	p. 66

RUBINETTI DI SCAMBIO A TRE VIE THREE-WAY DUAL SHUT-OFF VALVES

Attacco ingresso NPT o rotalock e attacco uscita NPT Inlet NPT or rotalock connection, outlet NPT	p. 67
Con adattatore With adaptors	p. 68
Per CO₂ (R744) con attacco ingresso NPT For CO ₂ (R744)	p. 69

VALVOLE DI SICUREZZA SAFETY VALVES

A scarico libero Free outlet	p. 70
A scarico convogliato Piped outlet	p. 70
In by-pass per compressori frigoriferi By-pass protection valves for refrigerant compressors	p. 71

RUBINETTI IN GHISA SFEROIDALE DUCTILE CAST IRON VALVES

Per tutti i tipi di freon For refrigerant fluids group II PED	p. 72
Per NH₃ (R717) for NH ₃ (R717)	p. 73
Per CO₂ (R744) for CO ₂ (R744)	p. 74

FLANGE FLANGES

Flange ovali per rubinetti Oval flanges for valves	p. 75
Flange in ghisa sferoidale Cast iron flanges	p. 75

GUARNIZIONI GASKETS

p. 76

RUBINETTI A SFERA BALL VALVES

Per tutti i tipi di freon sino a 45 bar For refrigerant fluids group II PED 45 bar	p. 77
Per CO₂ (R744) sino a 130 bar for CO ₂ (R744) up to 130 bar	p. 78
Per NH₃ (R717) for NH ₃ (R717)	p. 79

INDICATORI DI PASSAGGIO LIQUID AND MOISTURE INDICATORS

Attacchi ODS-SAE-male-female-O-Ring ODS-SAE-male-female-O-Ring connections	p. 80
Indicatori di livello e umidità per tutti i tipi di refrigerante Moisture sight glasses for refrigerant fluids group I and II PED	p. 81
Indicatori di passaggio e umidità per CO₂ (R744) Liquid and moisture indicators for CO ₂ (R744)	p. 82

FLANGE PER RICEVITORI ≥100LT E VALVOLE IN GHISA FLANGES FOR ≥100LT RECEIVERS AND DUCTILE CAST IRON VALVES	p. 83
---	-------

GUARNIZIONI PER FLANGE E VALVOLE IN GHISA GASKETS FOR FLANGES AND DUCTILE CAST IRON VALVES	p. 83
--	-------

ATTACCHI ROTALOCK A GOMITO PER TUTTI I TIPI DI FREON E CO₂ (R744) ELBOW ROTALOCK CONNECTIONS FOR ALL FLUIDS AND CO ₂ (R744)	p. 84
---	-------

ATTACCHI ROTALOCK PER TUTTI I FLUIDI E CO₂ (R744) ROTALOCK CONNECTIONS FOR ALL FLUIDS AND CO ₂ (R744)	p. 85
---	-------

RACCORDI PER TUTTI I FLUIDI REFRIGERANTI ROTALOCK SOLDERING CONNECTIONS FOR ALL FLUIDS	p. 87
--	-------

DADI E GAMBI NUTS AND SHANKS	p. 88
--	-------

RACCORDI SPECIALI A RICHIESTA PER TUTTI I FLUIDI SPECIAL CONNECTIONS ON DEMAND FOR ALL FLUIDS	p. 89
---	-------

GOMITI IN OTTONE BRASS ELBOWS	p. 91
---	-------

RACCORDI IN OTTONE BRASS FITTINGS	p. 92
---	-------

BOCCHETTONI IN OTTONE IN POLLICI E MILLIMETRI NUTS FOR INCH AND METRIC TUBES	p. 94
--	-------

GIUNTI IN OTTONE BRASS TEES	p. 96
---------------------------------------	-------

RACCORDI PER MECCANISMO DI CARICA ACCESS VALVES	p. 100
---	--------

Dati tecnici
Technical data

RICEVITORI DI LIQUIDO VERTICALI - Vertical liquid Receivers - Type AV

ØD mm	H mm	Volume liters	Category PED Fluids Group 1	Category PED Fluids Group 2
Ø65	185	0,50	Art. 3.3	Art. 3.3
	205	0,60	Art. 3.3	Art. 3.3
	105	0,40	Art. 3.3	Art. 3.3
Ø77	160	0,60	Art. 3.3	Art. 3.3
	180	0,70	Art. 3.3	Art. 3.3
	205	0,75	Art. 3.3	Art. 3.3
Ø100	225	0,85	Art. 3.3	Art. 3.3
	280	1,10	Art. 3.3	Art. 3.3
	160	1,00	Art. 3.3	Art. 3.3
Ø120	180	1,10	I	Art. 3.3
	200	1,20	II	I
	220	1,40	II	I
Ø125	240	1,50	II	I
	270	1,70	II	I
	333	2,10	II	I
Ø130	190	1,60	II	I
	250	2,20	II	I
	330	2,50	II	I
Ø150	342	3,50	II	I
	265	2,80	II	I
	280	2,90	II	I
Ø160	315	3,40	II	I
	365	4,00	II	I
	305	4,40	II	I
Ø180	360	5,30	III	II
	265	4,20	II	I
	345	5,70	III	II
Ø200	420	7,00	III	II
	270	5,40	III	II
	330	6,80	III	II
Ø220	395	8,30	III	II
	325	8,10	III	II
	350	8,80	III	II
Ø260	375	9,60	III	II
	365	11,0	III	II
	360	15,0	III	II
Ø280	420	18,0	III	II
	455	22,0	III	II

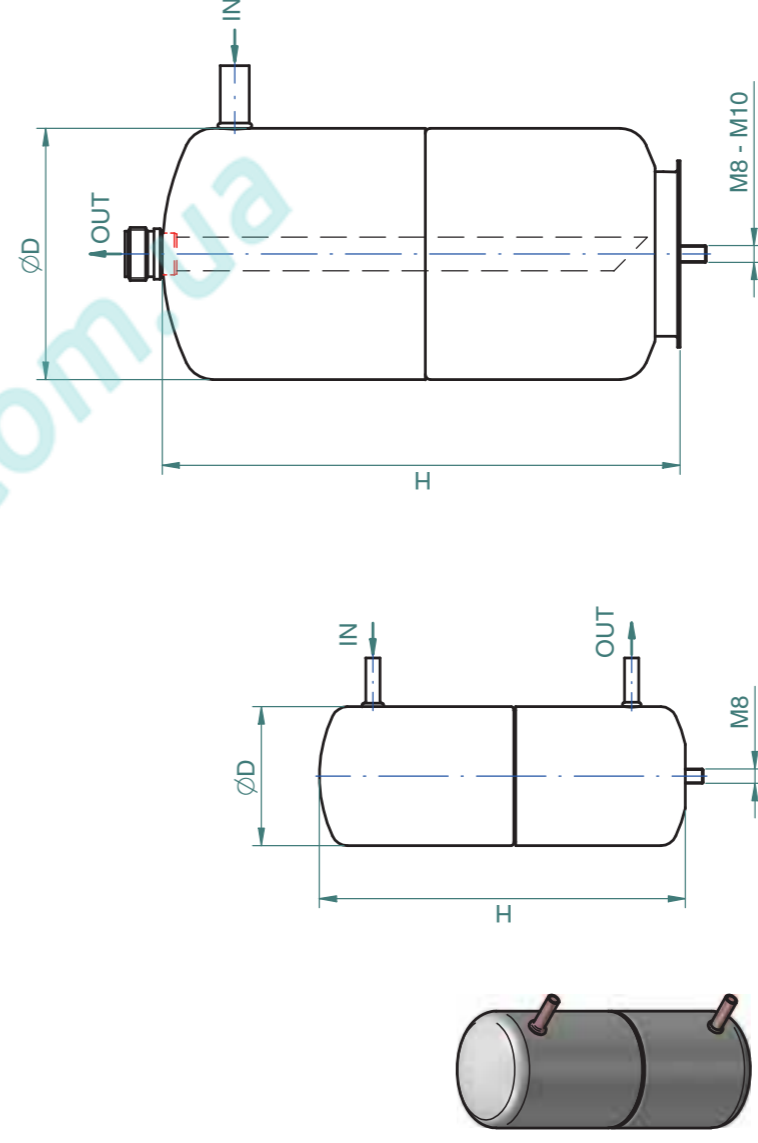

MASSIMA PRESSIONE DI LAVORO Maximum working pressure	PS 45 bar	PS 20 ÷ 33 bar
TEMPERATURA AMMISSIBILE Permissible temperature	TS -10/+120°C	TS -40/+120°C
PRESSIONE DI COLLAUDO Testing pressure	PT 65 bar	
COLORE Colour	BLACK RAL 9005	
RESISTENZA ALLA CORROSIONE IN NEBBIA SALINA DI 250 ORE SECONDO NORMA ASTM-B117. RESISTENZA FINO A 1000 ORE SU RICHIESTA. Corrosion resistance on salt spray at 250 hours according standard ASTM-B117. 1000 hours resistance on customer request.	CONFORME ALLA DIRETTIVA 97/23/CE (PED) According to Directive 97/23/CE (PED)	

COLOUR	BLACK RAL 9005
PERMISSIBLE PRESSURE	PS ON REQUEST
TESTING PRESSURE	PT (PSx1.43) bar
PERMISSIBLE TEMPERATURE	TS -10/+100 °C
REFRIGERANT	GROUP 2 PED

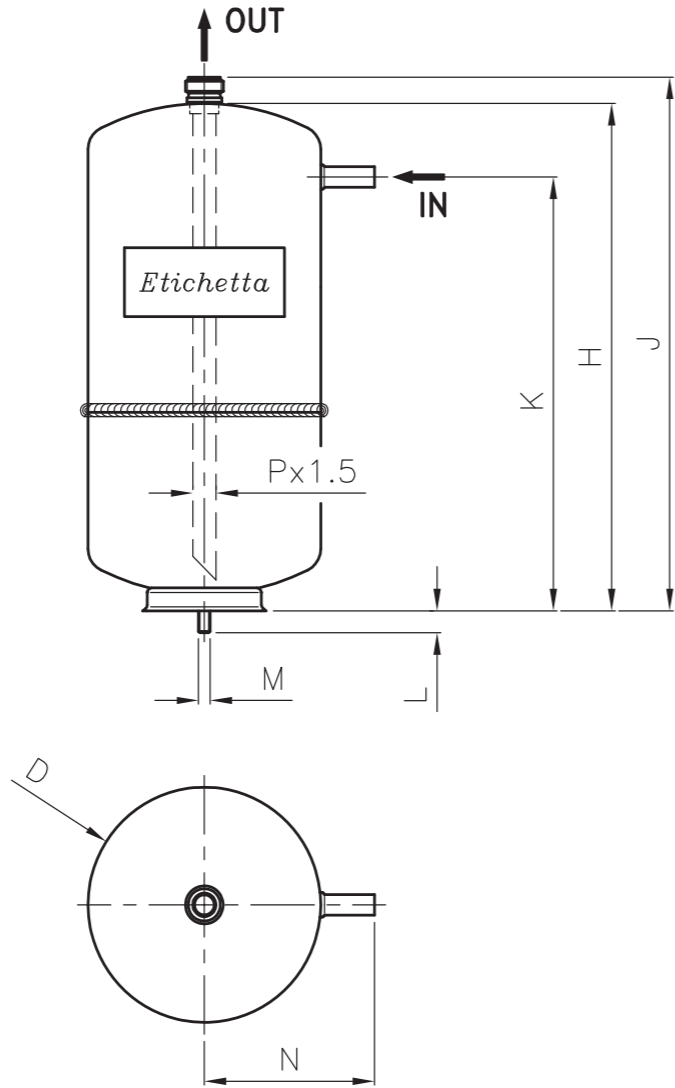
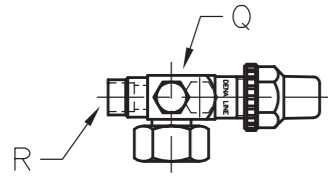

CODE RECEIVERS	VOLUME Liter	D mm	H mm	J mm	K mm	L mm	M mm	N mm	P mm	IN ODS	OUT Rotalock	CODE VALVES	Q mm	R ODS
COO.120.250.0	2.2	Ø120	250	268	215	15	M8	97	Ø16	1/2"	1"-14 UNS	39007R	Ø20	1/2"
COO.130.365.0	4.0	Ø130	365	383	320	15	M8	102	Ø16	1/2"	1"-14 UNS	39007R	Ø20	1/2"
COO.160.345.0	5.7	Ø160	345	363	295	15	M8	117	Ø16	1/2"	1"-14 UNS	39007R	Ø20	1/2"
COO.200.325.A	8.1	Ø200	325	343	265	23	M10	145	Ø16	16	1"-14 UNS	39007R	Ø20	1/2"
COO.220.365.A	11	Ø220	365	388	305	23	M10	155	Ø18	18	1 1/4"-12 UNF	39105R	Ø20	16
COO.260.360.0	15	Ø260	360	383	275	23	M10	175	Ø18	18	1 1/4"-12 UNF	43304R	Ø30	7/8"
DNL.260.420.A	18	Ø260	420	443	335	23	M10	175	Ø18	22	1 1/4"-12 UNF	39105R	Ø20	16
COO.280.455.0	22	Ø280	455	478	365	23	M10	185	Ø18	22	1 1/4"-12 UNF	43304R	Ø30	7/8"
DNL.280.485.0	24	Ø280	485	508	395	23	M10	185	Ø22	22	1 1/4"-12 UNF	43304R	Ø30	7/8"

denaline s.p.a. - PORDENONE - ITALY		DATA	TIPO DI MODIFICA	REV.
	SCALA			
TOLL. GENERALI: ±1.5%	TOLL. ANG.: ±1°	DISEGNATO		
		APPROVATO		
		REVISIONE N°		
Questo disegno e' di proprieta' della DENA-LINE S.p.A., qualsiasi uso improprio verra' perseguito a norma delle vigenti leggi.		DENOMINAZIONE	VERTICAL LIQUID RECEIVERS	DNL1
		CODICE	DNL	

RICEVITORI DI LIQUIDO ORIZZONTALI - Horizontal liquid Receivers - Type AH

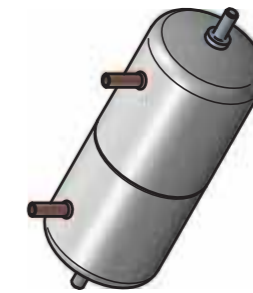
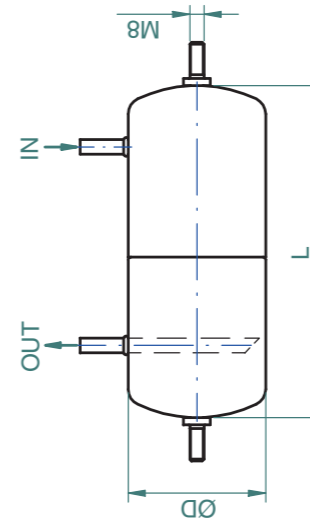
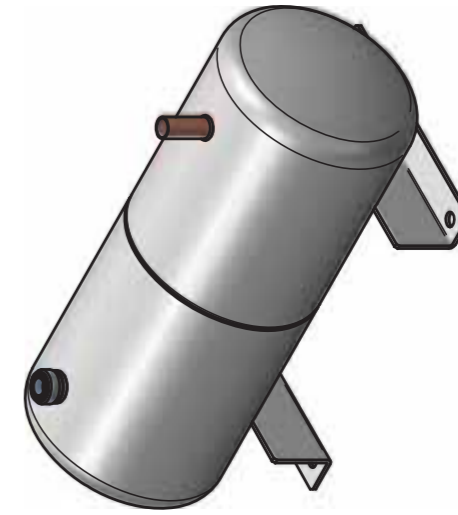
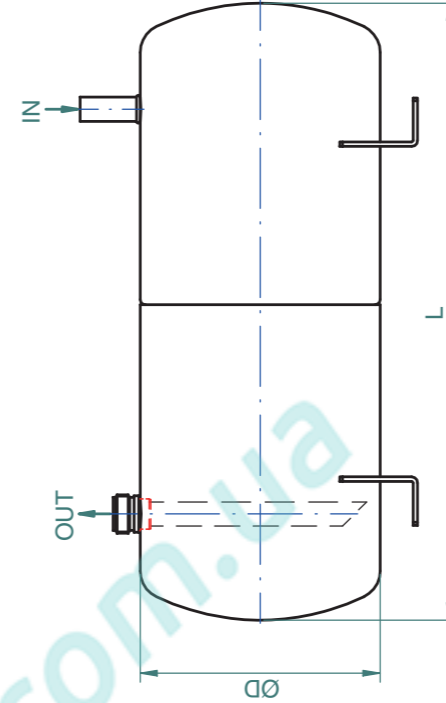

ØD mm	L mm	Volume liters	Category PED Fluids Group 1	Category PED Fluids Group 2
Ø65	185	0,50	Art. 3.3	Art. 3.3
Ø77	205	0,60	Art. 3.3	Art. 3.3
	105	0,40	Art. 3.3	Art. 3.3
Ø100	160	0,60	Art. 3.3	Art. 3.3
	180	0,70	Art. 3.3	Art. 3.3
Ø120	205	0,75	Art. 3.3	Art. 3.3
	225	0,85	Art. 3.3	Art. 3.3
Ø125	280	1,10	Art. 3.3	Art. 3.3
	146	1,00	Art. 3.3	Art. 3.3
Ø130	166	1,10	I	Art. 3.3
	187	1,20	II	I
Ø150	207	1,40	II	I
	228	1,50	II	I
Ø160	257	1,70	II	I
	320	2,10	II	I
Ø180	181	1,60	II	I
	239	2,20	II	I
Ø200	319	2,50	II	I
	331	3,50	II	I
Ø220	254	2,80	II	I
	269	2,90	II	I
Ø260	304	3,40	II	I
	354	4,00	II	I
Ø280	294	4,40	II	I
	349	5,30	III	II
	252	4,20	II	I
	332	5,70	III	II
	407	7,00	III	II
	259	5,40	III	II
	319	6,80	III	II
	384	8,30	III	II
	314	8,10	III	II
	340	8,80	III	II
	362	9,60	III	II
	350	11,0	III	II
	346	15,0	III	II
	406	18,0	III	II
	438	22,0	III	II

MASSIMA PRESSIONE DI LAVORO Maximum working pressure	PS 45 bar	PS 20 ÷ 33 bar
TEMPERATURA AMMISSIBILE Permissible temperature	TS -10/+120°C	TS -40/+120°C
PRESSIONE DI COLLAUDO Testing pressure	PT 65 bar	
COLORE Colour	BLACK RAL 9005	
RESISTENZA ALLA CORROSIONE IN NEBBIA SALINA DI 250 ORE SECONDO NORMA ASTM-B117. RESISTENZA FINO A 1000 ORE SU RICHIESTA. Corrosion resistance on salt spray at 250 hours according standard ASTM-B117. 1000 hours resistance on customer request.	CONFORME ALLA DIRETTIVA 97/23/CE (PED) According to Directive 97/23/CE (PED)	

RICEVITORI DI LIQUIDO VERTICALI - Vertical liquid Receivers - Type BV

ØD mm	H mm	Volume liters	Category PED Fluids Group 1 Art. 3.3	Category PED Fluids Group 2 Art. 3.3
Ø76,1	140	0,50	II	I
	350	1,30	II	I
Ø88,9	410	1,50	II	I
	700	2,70	II	I
Ø101,6	500	2,80	II	I
	630	3,20	II	I
Ø121,0	760	4,00	II	I
	278	1,80	II	I
Ø139,7	311	2,10	II	I
	431	2,90	II	I
Ø152,4	461	3,20	II	I
	845	5,90	III	II
Ø159,0	1011	7,20	III	II
	337	3,20	II	I
Ø168,3	512	5,00	III	II
	557	5,50	III	II
Ø193,7	672	6,70	III	II
	362	4,60	III	II
	495	6,50	III	II
	662	8,80	III	II
	867	11,7	III	II
	593	9,40	III	II
	623	9,90	III	II
	499	8,50	III	II
	561	9,70	III	II
	734	12,9	III	II
	855	15,1	III	II
	454	8,60	III	II
	519	9,90	III	II
	619	12,0	III	II
	654	12,7	III	II
	744	14,6	III	II
	789	15,5	III	II
	994	19,8	III	II
	1316	26,4	IV	III
	439	11,0	III	II
	570	14,6	III	II
	834	21,9	III	II
	964	25,5	IV	III

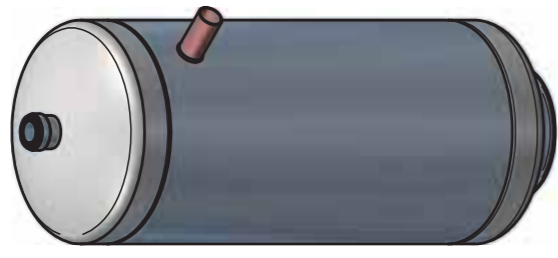
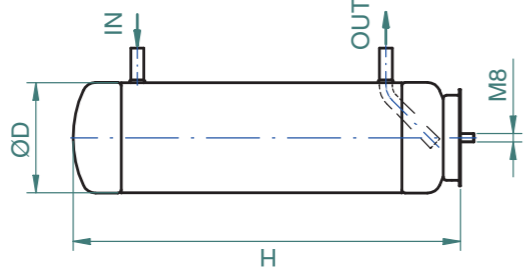
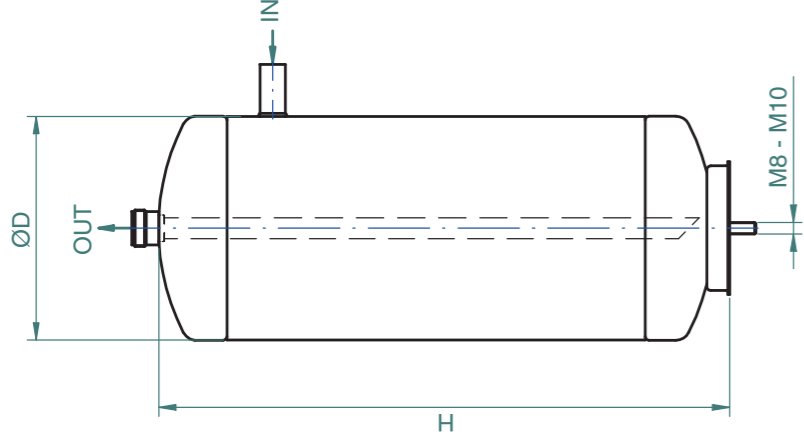

MASSIMA PRESSIONE DI LAVORO Maximum working pressure	PS 45 bar	PS 20 ÷ 33 bar
TEMPERATURA AMMISSIBILE Permissible temperature	TS -10/+120°C	TS -40/+120°C
PRESSIONE DI COLLAUDO Testing pressure	PT 65 bar	
COLORE Colour	BLACK RAL 9005	
RESISTENZA ALLA CORROSIONE IN NEBBIA SALINA DI 250 ORE SECONDO NORMA ASTM-B117. RESISTENZA FINO A 1000 ORE SU RICHIESTA. Corrosion resistance on salt spray at 250 hours according standard ASTM-B117. 1000 hours resistance on customer request.		
CONFORME ALLA DIRETTIVA 97/23/CE (PED) According to Directive 97/23/CE (PED)		

RICEVITORI DI LIQUIDO ORIZZONTALI - Horizontal liquid Receivers - Type BH

ØD mm	L mm	Volume liters	Category PED Fluids Group 1 Art. 3.3	Category PED Fluids Group 2 Art. 3.3
Ø76,1	130	0,50	II	I
	340	1,30	II	I
Ø88,9	400	1,50	II	I
	690	2,70	II	I
Ø101,6	490	2,80	II	I
	620	3,20	II	I
Ø121,0	750	4,00	II	I
	267	1,80	II	I
Ø139,7	300	2,10	II	I
	420	2,90	II	I
Ø152,4	450	3,20	II	I
	834	5,90	III	II
Ø159,0	1000	7,20	III	II
	325	3,20	II	I
Ø168,3	500	5,00	III	II
	545	5,50	III	II
Ø193,7	660	6,70	III	II
	350	4,60	III	II
	483	6,50	III	II
	650	8,80	III	II
	855	11,7	III	II
	580	9,40	III	II
	610	9,90	III	II
	486	8,50	III	II
	548	9,70	III	II
	721	12,9	III	II
	842	15,1	III	II
	440	8,60	III	II
	505	9,90	III	II
	605	12,0	III	II
	640	12,7	III	II
	730	14,6	III	II
	775	15,5	III	II
	980	19,8	III	II
	1302	26,4	IV	III
	425	11,0	III	II
	556	14,6	III	II
	820	21,9	III	II
	950	25,5	IV	III

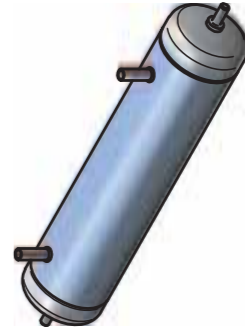
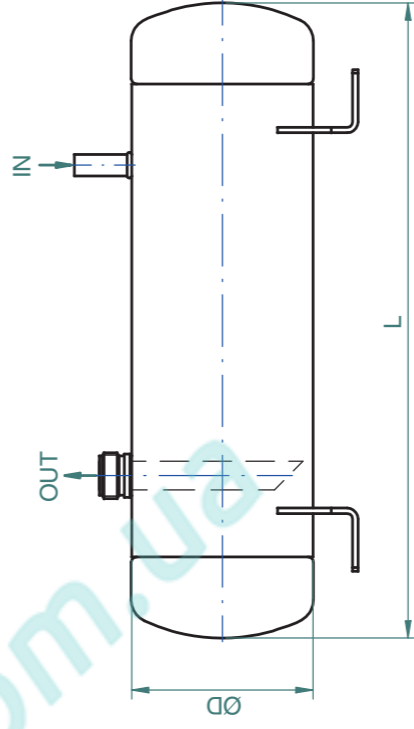
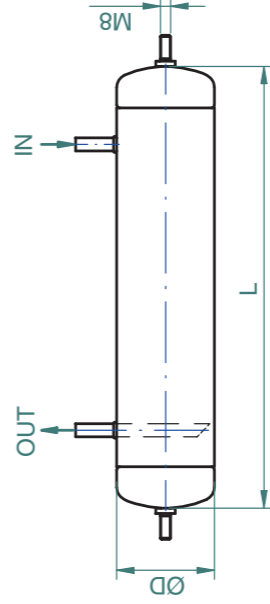

MASSIMA PRESSIONE DI LAVORO Maximum working pressure	PS 45 bar	PS 20 ÷ 33 bar
TEMPERATURA AMMISSIBILE Permissible temperature	TS -10/+120°C	TS -40/+120°C
PRESSIONE DI COLLAUDO Testing pressure	PT 65 bar	
COLORE Colour	BLACK RAL 9005	
RESISTENZA ALLA CORROSIONE IN NEBBIA SALINA DI 250 ORE SECONDO NORMA ASTM-B117. RESISTENZA FINO A 1000 ORE SU RICHIESTA. Corrosion resistance on salt spray at 250 hours according standard ASTM-B117. 1000 hours resistance on customer request.		
CONFORME ALLA DIRETTIVA 97/23/CE (PED) According to Directive 97/23/CE (PED)		

RICEVITORI DI LIQUIDO VERTICALI - Vertical liquid Receivers - Type CV

ØD mm	H mm	Volume liters	ØM mm	ØP mm	Category PED Fluids Group 1	Category PED Fluids Group 2
Ø219,1	925	30	204	Ø11	IV	III
	1075	35	204	Ø11	IV	III
	1345	45	204	Ø11	IV	III
Ø273,0	715	35	220	Ø13	IV	III
	1025	50	220	Ø13	IV	III
	1185	60	220	Ø13	IV	III
Ø323,9	1345	68	220	Ø13	IV	IV
	1245	88	280	Ø13	IV	III
	1345	95	280	Ø13	IV	IV
Ø406,4	1615	115	280	Ø13	IV	IV
	1355	150	350	Ø17	IV	IV
	1645	180	350	Ø17	IV	IV
Ø508,0	1805	200	350	Ø17	IV	IV
	1450	250	430	Ø19	IV	IV
	1805	320	430	Ø19	IV	IV
Ø508,0	2255	400	430	Ø19	IV	IV
	2725	490	430	Ø19	IV	IV

INDICATORE DI LIVELLO A SALDARE CON TECNOLOGIA BREVETTATA.
Sight Glass soldered with patented technology.

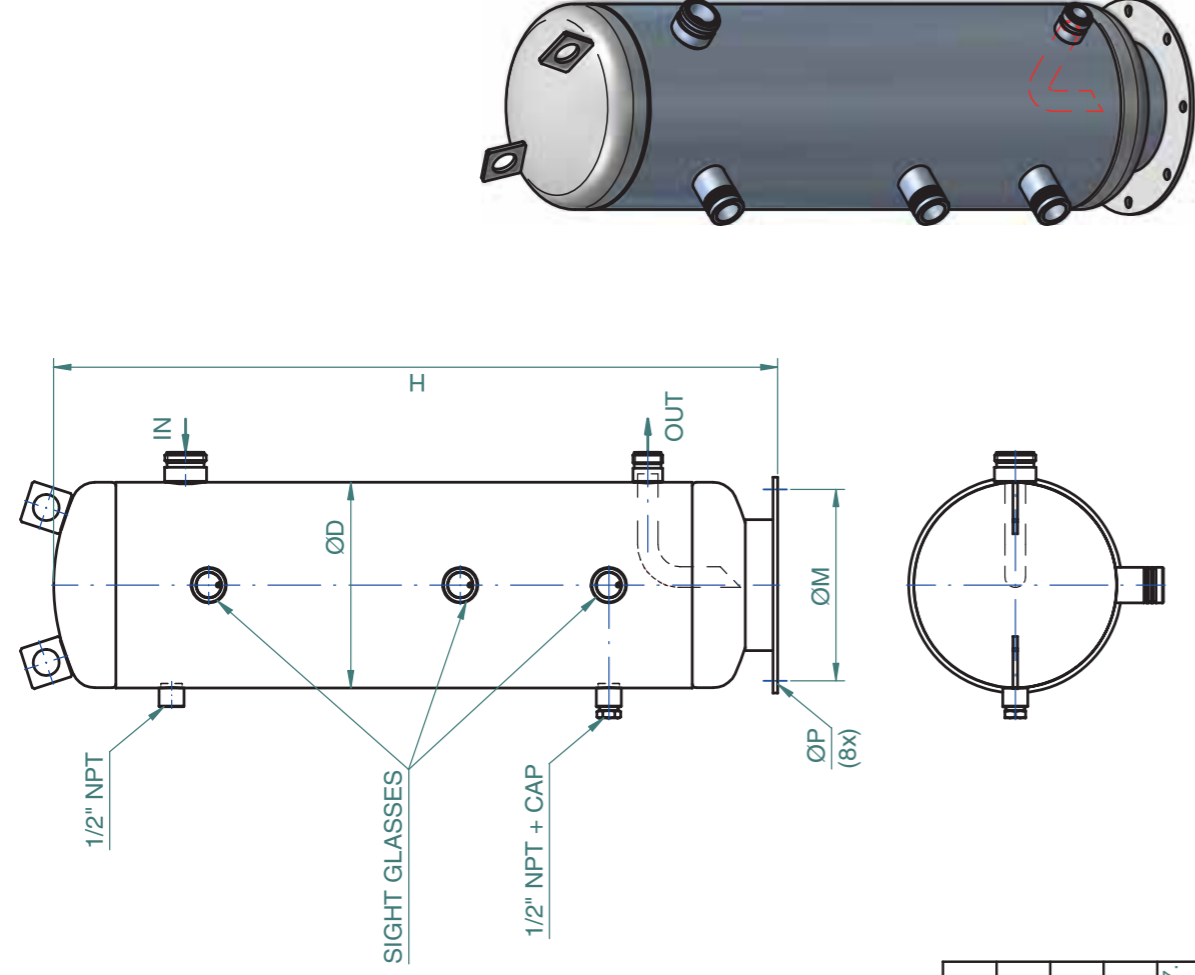

MASSIMA PRESSIONE DI LAVORO Maximum working pressure	PS 45 bar	PS 20 ÷ 33 bar
TEMPERATURA AMMISSIBILE Permissible temperature	TS -10/+120°C	TS -40/+120°C
PRESSIONE DI COLLAUDO Testing pressure	PT 65 bar	
COLORE Colour	BLACK RAL 9005	

RESISTENZA ALLA CORROSIONE IN NEBBIA SALINA DI 250 ORE SECONDO NORMA ASTM-B117.
RESISTENZA FINO A 1000 ORE SU RICHIESTA.
Corrosion resistance on salt spray at 250 hours according standard ASTM-B117.
1000 hours resistance on customer request.

CONFORME ALLA DIRETTIVA 97/23/CE (PED)
According to Directive 97/23/CE (PED)

CODE	VOLUME liter	DIAMETER mm	HEIGHT mm	CATEGORY PED	IN	OUT	A mm	B mm	C mm	D mm	E mm	F mm	G mm	H mm	L mm	M mm	N mm
TKV.219.925.0	30	Ø219,1	925	II	Rotolock 1 3/4"	Rotolock 1 1/4"	140	800	175	345	775	805	/	/	Ø22	Ø204	Ø11
TKV.219.1075.0	35	Ø219,1	1075	III	Rotolock 1 3/4"	Rotolock 1 1/4"	140	950	195	395	895	955	/	/	Ø22	Ø204	Ø11
TKV.219.1345.0 *	45	Ø219,1	1345	III	Rotolock 1 3/4"	Rotolock 1 1/4"	140	1220	235	495	1135	1225	/	/	Ø22	Ø204	Ø11
TKV.273.1025.0	50	Ø273,0	1025	III	Rotolock 1 3/4"	Rotolock 1 3/4"	160	880	185	370	830	885	1055	210	Ø35	Ø220	Ø13
TKV.273.1185.0 *	60	Ø273,0	1185	III	Rotolock 1 3/4"	Rotolock 1 3/4"	160	1040	210	435	985	1045	1215	210	Ø35	Ø220	Ø13
TKV.273.1345.0	70	Ø273,0	1345	III	Rotolock 1 3/4"	Rotolock 1 3/4"	160	1200	240	500	1140	1205	1375	210	Ø35	Ø220	Ø13
TKV.324.1245.0 *	90	Ø323,9	1245	III	Rotolock 2 1/4"	Rotolock 1 3/4"	200	1070	230	465	1055	1085	1275	240	Ø35	Ø280	Ø13
TKV.324.1615.0	120	Ø323,9	1615	IV	Rotolock 2 1/4"	Rotolock 2 1/4"	200	1170	250	510	1165	1185	1375	240	Ø35	Ø280	Ø13
TKV.406.1355.0	150	Ø406,4	1355	IV	Rotolock 2 1/4"	Rotolock 2 1/4"	280	1110	245	495	1110	1155	1380	290	Ø42	Ø280	Ø13
TKV.406.1645.0 *	180	Ø406,4	1645	IV	Rotolock 2 1/4"	Rotolock 2 1/4"	280	1390	280	580	1330	1445	1670	290	Ø42	Ø350	Ø17
TKV.406.1805.0	200	Ø406,4	1805	IV	Rotolock 2 1/4"	Rotolock 2 1/4"	280	1550	305	640	1475	1605	1830	290	Ø42	Ø350	Ø17
TKV.508.1450.0	250	Ø508,0	1450	IV	ODS 2 5/8"	Rotolock 2 1/4"	300	1180	270	535	1180	1230	1465	380	Ø42	Ø430	Ø19
TKV.508.1805.0	320	Ø508,0	1805	IV	ODS 3"	ODS 2 5/8"	300	1530	325	665	1520	1585	1830	380	Ø67	Ø430	Ø19
TKV.508.2255.0	410	Ø508,0	2255	IV	ODS 3"	ODS 3"	300	1980	395	835	1930	2035	2270	380	Ø76	Ø430	Ø19
TKV.508.2725.0	500	Ø508,0	2725	IV	ODS 3"	ODS 3"	300	2450	470	1000	2340	2505	2740	380	Ø76	Ø430	Ø19

* SPECIAL

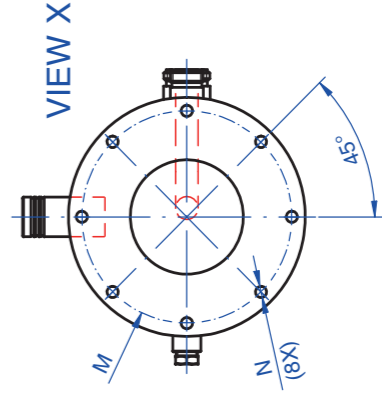
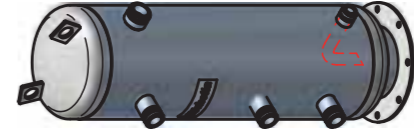
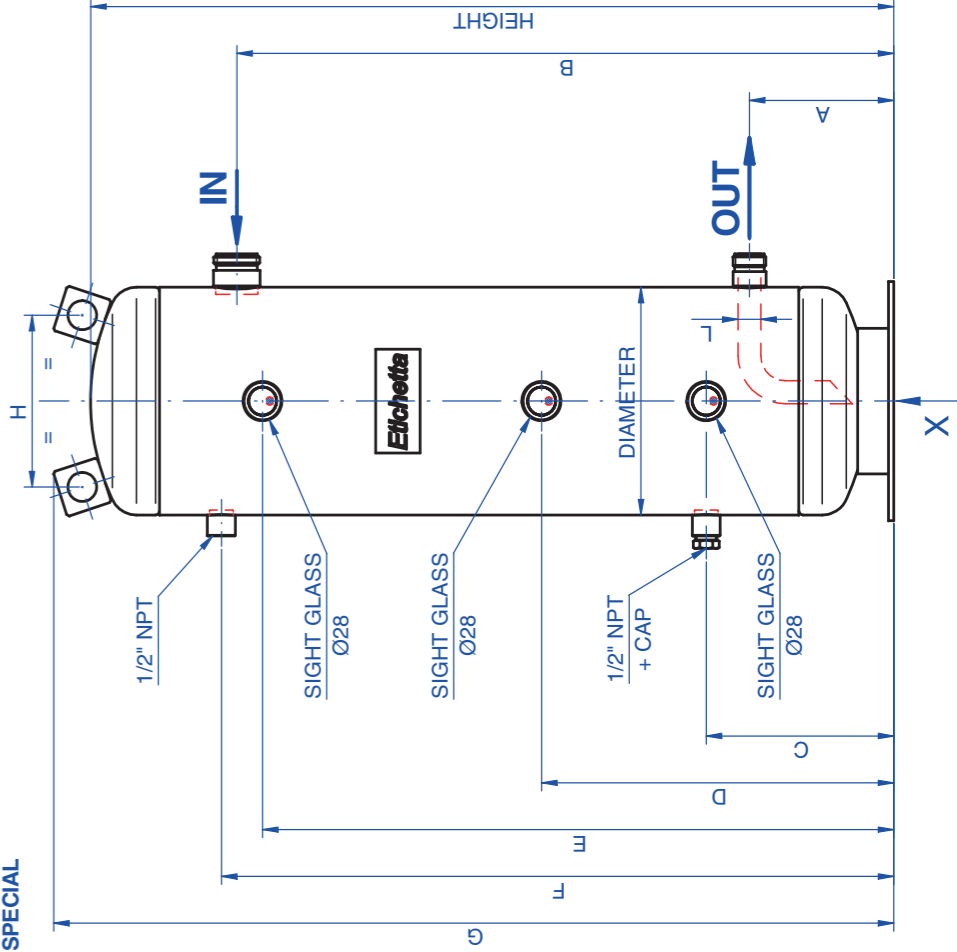

MANUFACTURED ACCORDING TO DIRECTIVE 97/23/CE	
PERMISSIBLE PRESSURE	PS 33 bar
TESTING PRESSURE	PT 47,2 bar
PERMISSIBLE TEMPERATURE	TS -10/+100 C°
REFRIGERANT	GROUP 2 PED
COLOUR	BLACK RAL 9005

TOLLERANZE GENERALI: ± 5%	REVISIONE N°	0	EMMISSIONE DISEGNO	0
TOLLERANZE ANGOLARI: ± 5%	DENOMINAZIONE	VERTICAL RECEIVERS	TIPO DI MODIFICA	REV.
	CODICE	TKV		

RICEVITORI DI LIQUIDO ORIZZONTALI - Horizontal liquid Receivers - Type CH

ØD mm	L mm	Volume liters	M mm	P mm	Category PED Fluids Group 1	Category PED Fluids Group 2
Ø219,1	900	30	180	Ø13X18	IV	III
	1050	35	180	Ø13X18	IV	III
	1320	45	180	Ø13X18	IV	III
Ø273,0	690	35	220	Ø17X22	IV	III
	1000	50	220	Ø17X22	IV	III
	1160	60	220	Ø17X22	IV	III
Ø323,9	1320	68	220	Ø17X22	IV	IV
	1220	88	250	Ø17X22	IV	III
	1320	95	250	Ø17X22	IV	IV
Ø406,4	1590	115	250	Ø17X22	IV	IV
	1330	150	300	Ø19X24	IV	IV
	1620	180	300	Ø19X24	IV	IV
Ø508,0	1780	200	300	Ø19X24	IV	IV
	1425	250	400	Ø19X24	IV	IV
	1780	320	400	Ø19X24	IV	IV
Ø508,0	2230	400	400	Ø19X24	IV	IV
	2700	490	400	Ø19X24	IV	IV

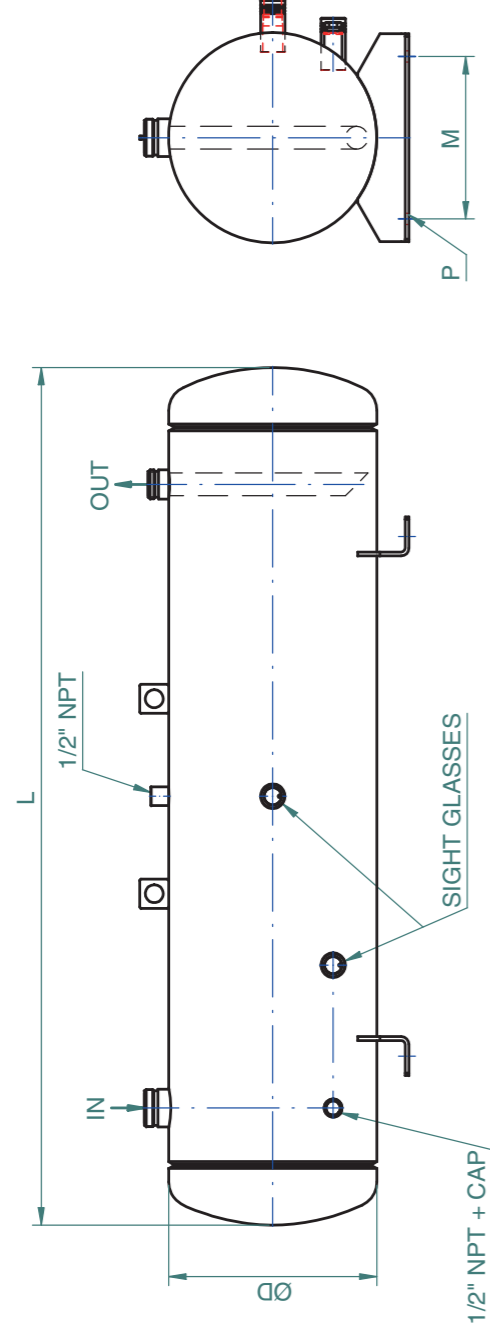

INDICATORE DI LIVELLO A SALDARE CON TECNOLOGIA BREVETTATA. Sight Glass soldered with patented technology.

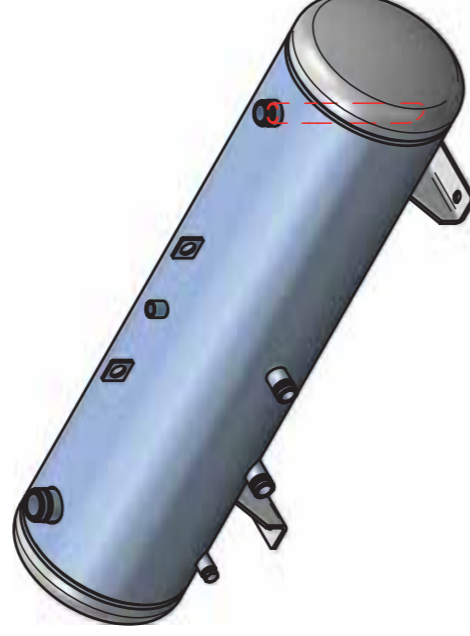

MASSIMA PRESSIONE DI LAVORO Maximum working pressure	PS 45 bar	PS 20 ÷ 33 bar
TEMPERATURA AMMISSIBILE Permissible temperature	TS -10/+120°C	TS -40/+120°C
PRESSIONE DI COLLAUDO Testing pressure	PT 65 bar	
COLORE Colour	BLACK RAL 9005	

RESISTENZA ALLA CORROSIONE IN NEBBIA SALINA DI 250 ORE SECONDO NORMA ASTM-B117.
RESISTENZA FINO A 1000 ORE SU RICHIESTA.
Corrosion resistance on salt spray at 250 hours according standard ASTM-B117.
1000 hours resistance on customer request.

CONFORME ALLA DIRETTIVA 97/23/CE (PED)
According to Directive 97/23/CE (PED)

MANUFACTURED ACCORDING TO DIRECTIVE 97/23/CE	
PERMISSIBLE PRESSURE	PS 33 bar
TESTING PRESSURE	PT 47,2 bar
PERMISSIBLE TEMPERATURE	TS -10/+100 C°
REFRIGERANT	GROUP 2 PED
COLOUR	BLACK RAL 9005

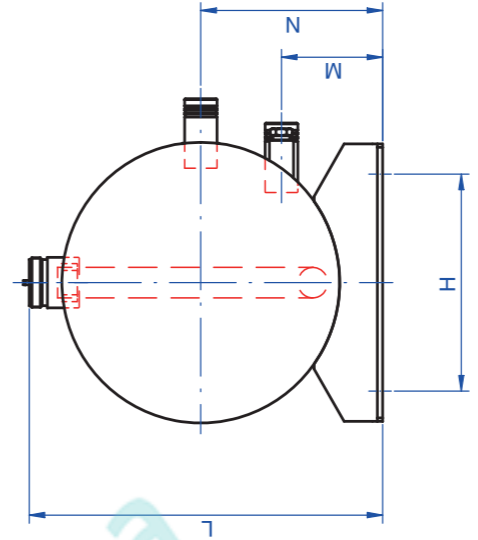
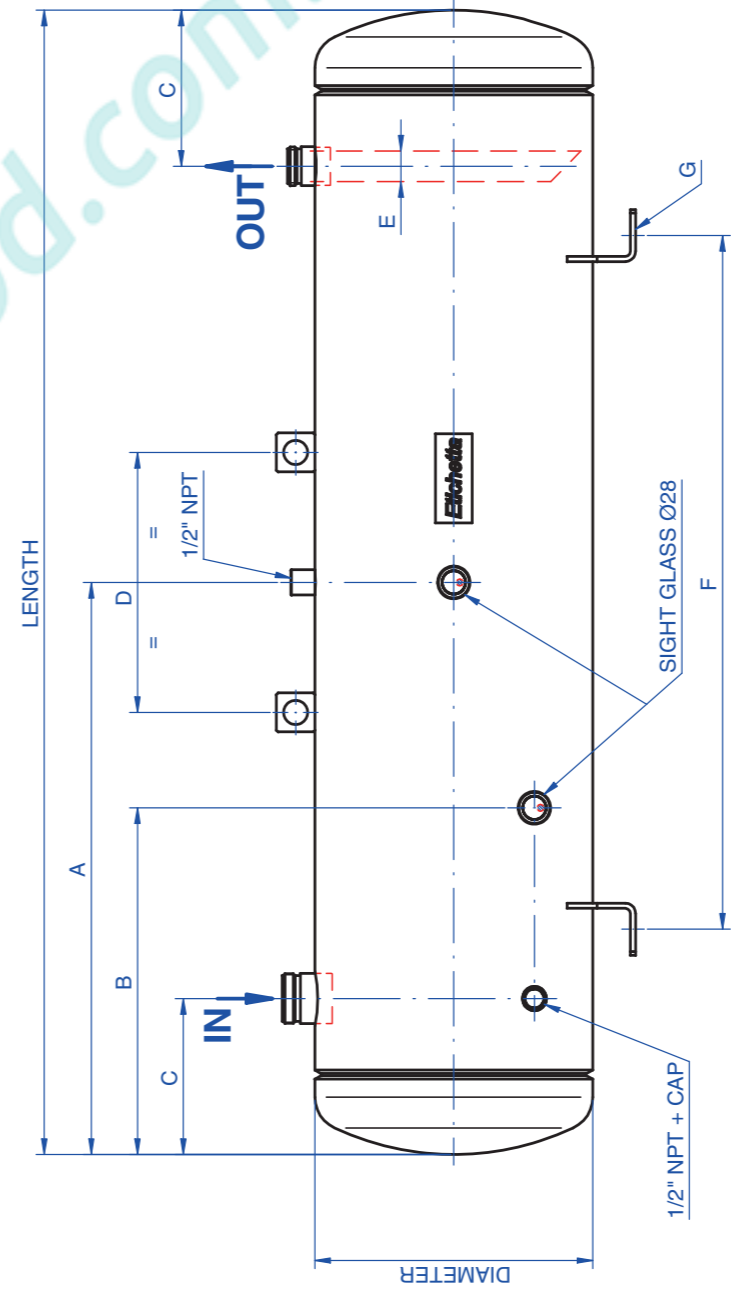

CODE	VOLUME liter	DIAMETER mm	LENGTH mm	CATEGORY PED	IN	OUT	A mm	B mm	C mm	D mm	E mm	F mm	G mm	H mm	L mm	M mm	N mm
TKH.219.900.0	30	Ø219,1	900	II	Rotalock 1 3/4"	Rotalock 1 1/4"	450	290	130	/	Ø22	500	Ø19x18	180	292	94	150
TKH.219.1050.0	35	Ø219,1	1050	III	Rotalock 1 3/4"	Rotalock 1 1/4"	525	330	130	/	Ø22	600	Ø19x18	180	292	94	150
TKH.219.1320.0*	45	Ø219,1	1320	III	Rotalock 1 3/4"	Rotalock 1 1/4"	660	400	130	/	Ø22	800	Ø19x18	180	292	94	150
TKH.273.1000.0	50	Ø273,0	1000	III	Rotalock 1 3/4"	Rotalock 1 1/4"	500	320	160	250	Ø22	550	Ø17x22	220	350	108	177
TKH.273.1160.0*	60	Ø273,0	1160	III	Rotalock 1 3/4"	Rotalock 1 3/4"	580	350	160	300	Ø35	700	Ø17x22	220	350	108	177
TKH.273.1320.0	70	Ø273,0	1320	III	Rotalock 1 3/4"	Rotalock 1 3/4"	660	400	160	300	Ø35	800	Ø17x22	220	350	108	177
TKH.324.1220.0*	90	Ø323,9	1220	III	Rotalock 2 1/4"	Rotalock 1 3/4"	610	380	180	300	Ø35	750	Ø17x22	250	412	118	212
TKH.324.1590.0	120	Ø323,9	1590	IV	Rotalock 2 1/4"	Rotalock 2 1/4"	660	400	180	300	Ø42	800	Ø17x22	250	412	118	212
TKH.406.1330.0	150	Ø406,4	1330	IV	Rotalock 2 1/4"	Rotalock 2 1/4"	795	480	180	300	Ø42	950	Ø17x22	250	412	118	212
TKH.406.1620.0*	180	Ø406,4	1620	IV	Rotalock 2 1/4"	Rotalock 2 1/4"	665	400	240	300	Ø42	800	Ø19x24	300	494	150	253
TKH.406.1780.0	200	Ø406,4	1780	IV	Rotalock 2 1/4"	Rotalock 2 1/4"	810	450	240	350	Ø42	950	Ø19x24	300	494	150	253
TKH.508.1425.0	250	Ø508,0	1425	IV	ODS 2 5/8"	Rotalock 2 1/4"	712,5	450	280	300	Ø42	800	Ø19x24	400	628	195	324
TKH.508.1780.0	320	Ø508,0	1780	IV	ODS 3"	ODS 2 5/8"	890	550	300	400	Ø67	1000	Ø19x24	400	633	195	324
TKH.508.2230.0	410	Ø508,0	2230	IV	ODS 3"	ODS 3"	1115	650	300	500	Ø76	1300	Ø19x24	400	633	195	324
TKH.508.2700.0	500	Ø508,0	2700	IV	ODS 3"	ODS 3"	1350	800	300	600	Ø76	1500	Ø19x24	400	633	195	324



* SPECIAL

TOLLERANZE GENERALI: ± 5%	TOLLERANZE ANGOLARI: ± 5%	REVISIONE N°	0	20/09/13	EMMISSIONE DISEGNO	0
		DENOMINAZIONE	HORIZONTAL RECEIVERS		TIPO DI MODIFICA	REV.
		CODICE	TKH			

RICEVITORI DI LIQUIDO VERTICALI - Vertical liquid receivers - DLV-CO2 (R744)

ØD mm	H1 mm	H2 mm	90 bar		130 bar	
			Volume liters	Category PED	Volume liters	Category PED
Ø76,1	140	130	0,50	Art. 3.3	0,40	Art. 3.3
	350	340	1,30	I	1,10	I
	410	400	1,50	I	1,40	I
	700	690	2,60	II	2,40	II
	278	267	1,80	I	1,60	II
Ø101,6	311	300	2,00	I	1,80	II
	431	420	2,80	II	2,60	II
	461	450	3,00	II	2,80	II
	845	834	5,70	II	5,40	II
	1011	1000	6,90	II	6,40	II
Ø121,0	337	325	3,00	II	2,80	II
	512	500	4,70	II	4,40	II
	557	545	5,20	II	4,80	II
	672	660	6,30	II	5,90	II
	362	350	4,30	II	4,00	II
Ø139,7	495	483	6,00	II	5,70	II
	662	650	8,30	II	7,60	II
	867	855	11,0	II	10,3	III
	454	440	7,90	II	7,50	II
	519	505	9,10	II	8,70	III
Ø168,3	619	605	11,0	II	10,5	III
	654	640	11,8	III	11,1	III
	744	730	13,5	III	12,8	III
	789	775	14,3	III	13,6	III
	994	980	18,3	III	17,3	III
Ø219,1	1316	1302	24,5	III	23,0	III
	345	320	9,30	III	8,80	III
	475	450	13,5	III	12,7	III
	500	475	14,3	III	13,5	III
	590	565	17,3	III	16,2	III
Ø219,1	725	700	21,6	III	20,4	III
	780	755	23,4	III	22,0	III
	925	900	28,1	III	26,5	IV
	975	950	29,7	III	28,0	IV
	1180	1155	36,4	IV	34,2	IV
1610	1585	50,3	IV	47,4	IV	

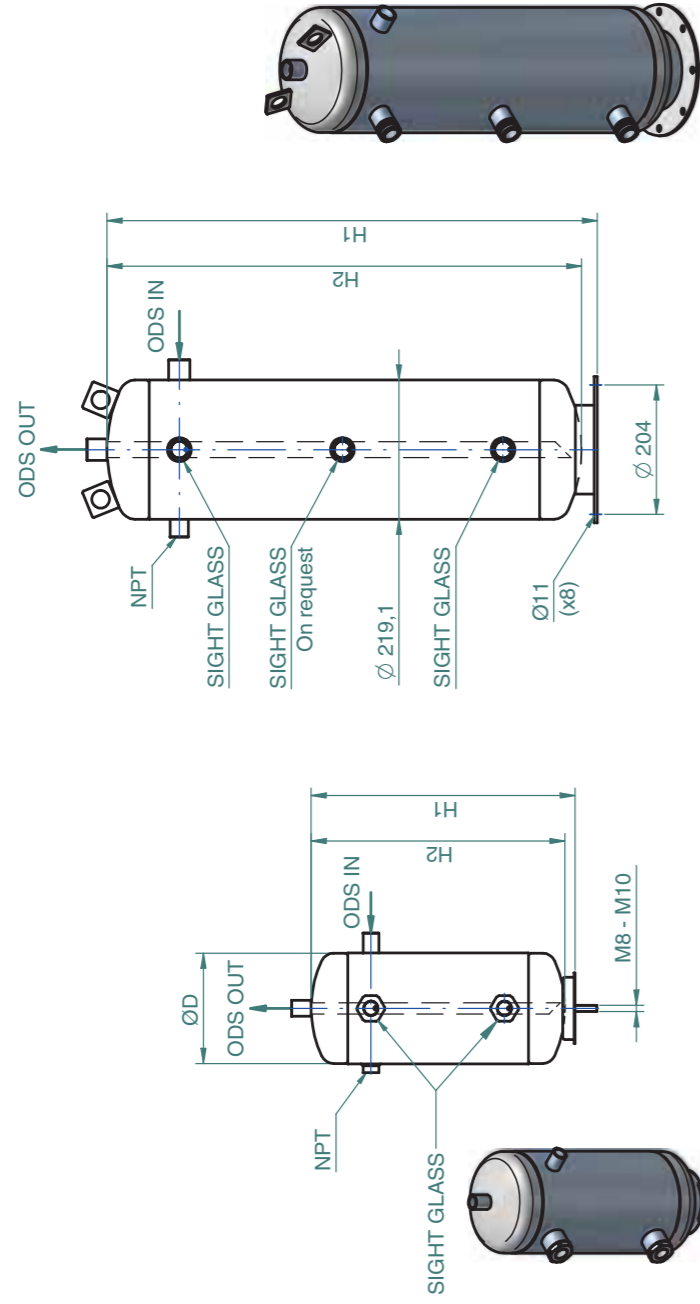

MASSIMA PRESSIONE DI LAVORO Maximum working pressure	PS 90 bar	PS 130 bar
PRESSIONE DI COLLAUDO Testing pressure	PT 128,7 bar	PT 185,9 bar
TEMPERATURA AMMISSIBILE Permissible temperature	TS -30/+120°C	
FLUIDO REFRIGERANTE Refrigerant	GROUP 2 PED	
COLORE Colour	BLACK RAL 9005	
DIMENSIONE ODS ODS dimension	A RICHIESTA DEL CLIENTE On customer request	
RESISTENZA ALLA CORROSIONE IN NEBBIA SALINA DI 250 ORE SECONDO NORMA ASTM-B117. RESISTENZA FINO A 1000 ORE SU RICHIESTA. Corrosion resistance on salt spray at 250 hours according standard ASTM-B117. 1000 hours resistance on customer request.	CONFORME ALLA DIRETTIVA 97/23/CE (PED) According to Directive 97/23/CE (PED)	

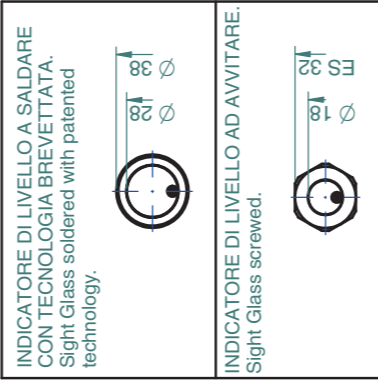

RICEVITORI DI LIQUIDO ORIZZONTALI - Horizontal liquid receivers - DLH-CO2 (R744)

ØD mm	L mm	90 bar		130 bar	
		Volume liters	Category PED	Volume liters	Category PED
Ø76,1	130	0,50	Art. 3.3	0,40	Art. 3.3
	340	1,30	I	1,10	I
	400	1,50	I	1,40	I
	690	2,60	II	2,40	II
	267	1,80	I	1,60	II
Ø101,6	300	2,00	I	1,80	II
	420	2,80	II	2,60	II
	450	3,00	II	2,80	II
	834	5,70	II	5,40	II
	1000	6,90	II	6,40	II
Ø121,0	325	3,00	II	2,80	II
	500	4,70	II	4,40	II
	545	5,20	II	4,80	II
	660	6,30	II	5,90	II
	350	4,30	II	4,00	II
Ø139,7	483	6,00	II	5,70	II
	650	8,30	II	7,60	II
	855	11,0	II	10,3	III
	440	7,90	II	7,50	II
	505	9,10	II	8,70	III
Ø168,3	605	11,0	II	10,5	III
	640	11,8	III	11,1	III
	730	13,5	III	12,8	III
	775	14,3	III	13,6	III
	980	18,3	III	17,3	III
Ø219,1	1302	24,5	III	23,0	III
	320	9,30	III	8,80	III
	450	13,5	III	12,7	III
	475	14,3	III	13,5	III
	565	17,3	III	16,2	III
Ø219,1	700	21,6	III	20,4	III
	755	23,4	III	22,0	III
	900	28,1	III	26,5	IV
	950	29,7	III	28,0	IV
	1155	36,4	IV	34,2	IV

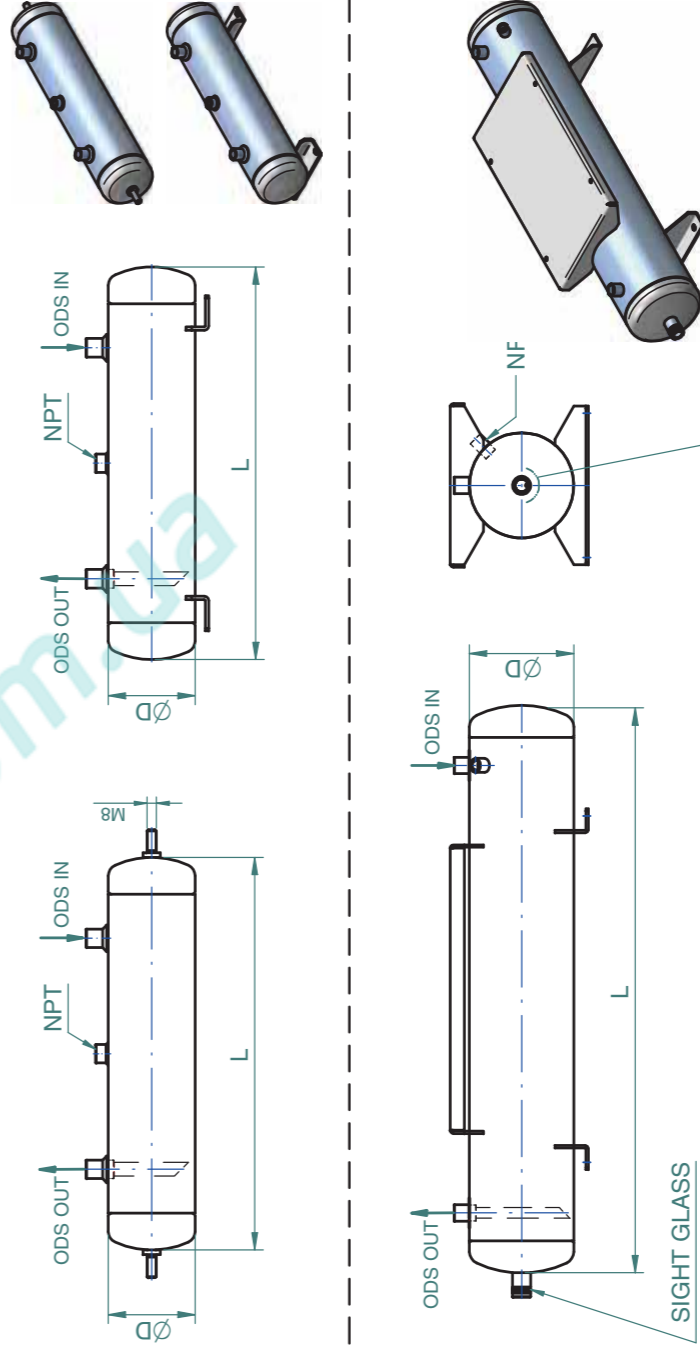

MASSIMA PRESSIONE DI LAVORO Maximum working pressure	PS 90 bar	PS 130 bar
PRESSIONE DI COLLAUDO Testing pressure	PT 128,7 bar	PT 185,9 bar
TEMPERATURA AMMISSIBILE Permissible temperature	TS -30/+120°C	
FLUIDO REFRIGERANTE Refrigerant	GROUP 2 PED	
COLORE Colour	BLACK RAL 9005	
DIMENSIONE ODS ODS dimension	A RICHIESTA DEL CLIENTE On customer request	
RESISTENZA ALLA CORROSIONE IN NEBBIA SALINA DI 250 ORE SECONDO NORMA ASTM-B117. RESISTENZA FINO A 1000 ORE SU RICHIESTA. Corrosion resistance on salt spray at 250 hours according standard ASTM-B117. 1000 hours resistance on customer request.	CONFORME ALLA DIRETTIVA 97/23/CE (PED) According to Directive 97/23/CE (PED)	

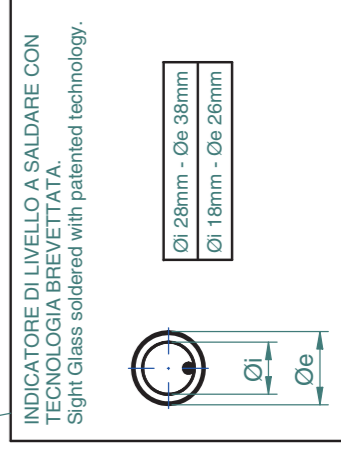

COMPONENTI PER RICEVITORI
Components for receivers

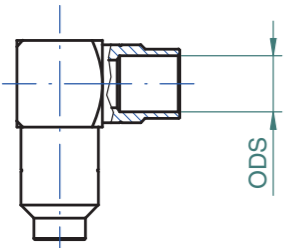
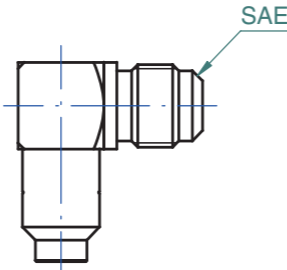
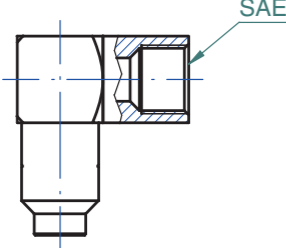
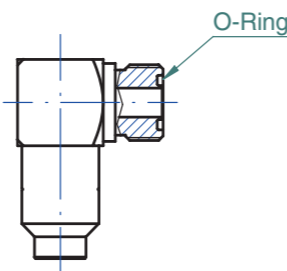
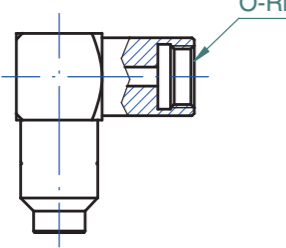
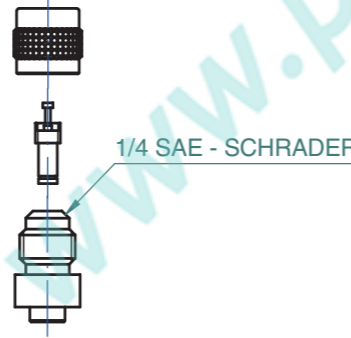
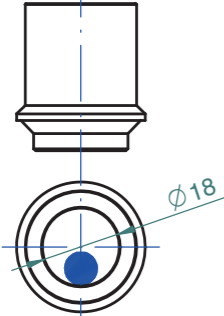
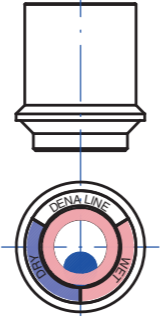
<table border="1"> <thead> <tr> <th>ODS mm</th> <th>ODS inch</th> </tr> </thead> <tbody> <tr><td>6</td><td>/</td></tr> <tr><td>/</td><td>1/4"</td></tr> <tr><td>8</td><td>/</td></tr> <tr><td>/</td><td>3/8"</td></tr> <tr><td>10</td><td>/</td></tr> <tr><td>12</td><td>/</td></tr> <tr><td>/</td><td>1/2"</td></tr> <tr><td>16</td><td>5/8"</td></tr> <tr><td>18</td><td>/</td></tr> <tr><td>/</td><td>3/4"</td></tr> </tbody> </table> <p>GOMITI CON ATTACCO ODS Elbows with ODS connection</p> 	ODS mm	ODS inch	6	/	/	1/4"	8	/	/	3/8"	10	/	12	/	/	1/2"	16	5/8"	18	/	/	3/4"	<table border="1"> <thead> <tr> <th>SAE</th> </tr> </thead> <tbody> <tr><td>1/4"</td></tr> <tr><td>3/8"</td></tr> <tr><td>1/2"</td></tr> <tr><td>5/8"</td></tr> <tr><td>3/4"</td></tr> </tbody> </table> <p>GOMITI CON ATTACCO MASCHIO SAE Elbows with SAE male connection</p> 	SAE	1/4"	3/8"	1/2"	5/8"	3/4"
ODS mm	ODS inch																												
6	/																												
/	1/4"																												
8	/																												
/	3/8"																												
10	/																												
12	/																												
/	1/2"																												
16	5/8"																												
18	/																												
/	3/4"																												
SAE																													
1/4"																													
3/8"																													
1/2"																													
5/8"																													
3/4"																													
<table border="1"> <thead> <tr> <th>SAE</th> </tr> </thead> <tbody> <tr><td>1/4"</td></tr> <tr><td>3/8"</td></tr> <tr><td>1/2"</td></tr> <tr><td>5/8"</td></tr> <tr><td>3/4"</td></tr> </tbody> </table> <p>GOMITI CON ATTACCO FEMMINA SAE Elbows with SAE female connection</p> 	SAE	1/4"	3/8"	1/2"	5/8"	3/4"	<table border="1"> <thead> <tr> <th>O-RING</th> </tr> </thead> <tbody> <tr><td>1/4"</td></tr> <tr><td>3/8"</td></tr> <tr><td>1/2"</td></tr> <tr><td>5/8"</td></tr> </tbody> </table> <p>GOMITI CON ATTACCO MASCHIO O-RING Elbows with O-Ring male connection</p> 	O-RING	1/4"	3/8"	1/2"	5/8"																	
SAE																													
1/4"																													
3/8"																													
1/2"																													
5/8"																													
3/4"																													
O-RING																													
1/4"																													
3/8"																													
1/2"																													
5/8"																													
<table border="1"> <thead> <tr> <th>O-RING</th> </tr> </thead> <tbody> <tr><td>1/4"</td></tr> <tr><td>3/8"</td></tr> <tr><td>1/2"</td></tr> <tr><td>5/8"</td></tr> </tbody> </table> <p>GOMITI CON ATTACCO FEMMINA O-RING Elbows with O-Ring female connection</p> 	O-RING	1/4"	3/8"	1/2"	5/8"	<p>RACCORDO SCHRADER 1/4" SAE 1/4" SAE SCHRADER connections</p> 																							
O-RING																													
1/4"																													
3/8"																													
1/2"																													
5/8"																													
<p>INDICATORE DI LIVELLO A SALDARE CON TECNOLOGIA BREVETTATA Sight Glass soldered with patented technology</p> 	<p>INDICATORE DI UMIDITA' A SALDARE CON TECNOLOGIA BREVETTATA Moisture Sight Glass soldered with patented technology</p> 																												

COMPONENTI PER RICEVITORI
Components for receivers

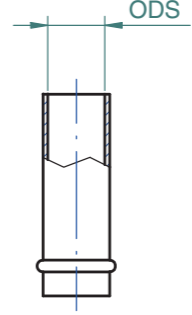
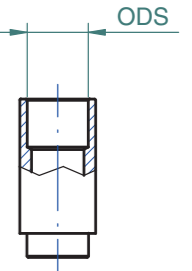
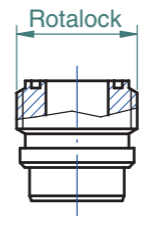
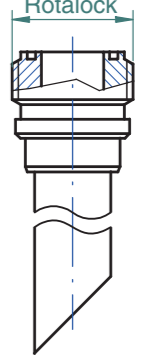
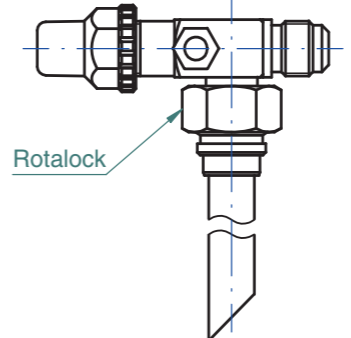
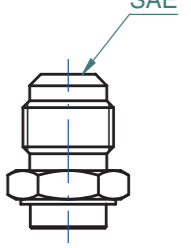
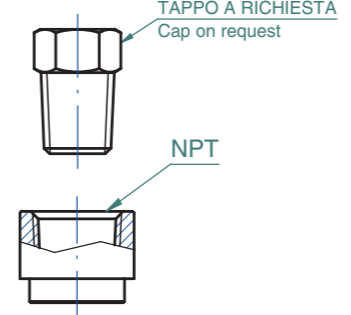
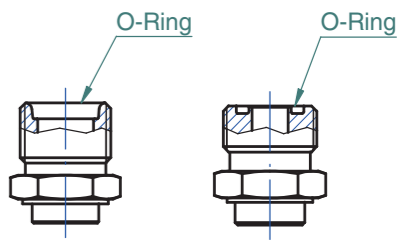
<table border="1"> <thead> <tr> <th>ODS mm</th> <th>ODS inch</th> <th>ODS mm</th> <th>ODS inch</th> </tr> </thead> <tbody> <tr><td>4</td><td>/</td><td>22</td><td>/</td></tr> <tr><td>6</td><td>/</td><td>/</td><td>7/8"</td></tr> <tr><td>/</td><td>1/4"</td><td>28</td><td>/</td></tr> <tr><td>8</td><td>/</td><td>/</td><td>1 1/8"</td></tr> <tr><td>/</td><td>3/8"</td><td>35</td><td>1 3/8"</td></tr> <tr><td>10</td><td>/</td><td></td><td></td></tr> <tr><td>12</td><td>/</td><td></td><td></td></tr> <tr><td>/</td><td>1/2"</td><td></td><td></td></tr> <tr><td>16</td><td>5/8"</td><td></td><td></td></tr> <tr><td>18</td><td>/</td><td></td><td></td></tr> <tr><td>/</td><td>3/4"</td><td></td><td></td></tr> <tr><td>20</td><td>/</td><td></td><td></td></tr> </tbody> </table> <p>TUBI IN RAME A BRASARE Brazed copper Pipes</p> 	ODS mm	ODS inch	ODS mm	ODS inch	4	/	22	/	6	/	/	7/8"	/	1/4"	28	/	8	/	/	1 1/8"	/	3/8"	35	1 3/8"	10	/			12	/			/	1/2"			16	5/8"			18	/			/	3/4"			20	/			<table border="1"> <thead> <tr> <th>ODS mm</th> <th>ODS inch</th> <th>ODS mm</th> <th>ODS inch</th> </tr> </thead> <tbody> <tr><td>4</td><td>/</td><td>22</td><td>/</td></tr> <tr><td>6</td><td>/</td><td>/</td><td>7/8"</td></tr> <tr><td>/</td><td>1/4"</td><td>28</td><td>/</td></tr> <tr><td>8</td><td>/</td><td>/</td><td>1 1/8"</td></tr> <tr><td>/</td><td>3/8"</td><td>35</td><td>1 3/8"</td></tr> <tr><td>10</td><td>/</td><td></td><td></td></tr> <tr><td>12</td><td>/</td><td>42</td><td>/</td></tr> <tr><td>/</td><td>1/2"</td><td>54</td><td>2 1/8"</td></tr> <tr><td>16</td><td>5/8"</td><td>64</td><td>/</td></tr> <tr><td>18</td><td>/</td><td>/</td><td>2 5/8"</td></tr> <tr><td>/</td><td>3/4"</td><td>76</td><td>/</td></tr> <tr><td>20</td><td>/</td><td>/</td><td>3 1/8"</td></tr> </tbody> </table> <p>TUBI IN ACCIAIO A SALDARE Welded steel Pipes</p> 	ODS mm	ODS inch	ODS mm	ODS inch	4	/	22	/	6	/	/	7/8"	/	1/4"	28	/	8	/	/	1 1/8"	/	3/8"	35	1 3/8"	10	/			12	/	42	/	/	1/2"	54	2 1/8"	16	5/8"	64	/	18	/	/	2 5/8"	/	3/4"	76	/	20	/	/	3 1/8"
ODS mm	ODS inch	ODS mm	ODS inch																																																																																																						
4	/	22	/																																																																																																						
6	/	/	7/8"																																																																																																						
/	1/4"	28	/																																																																																																						
8	/	/	1 1/8"																																																																																																						
/	3/8"	35	1 3/8"																																																																																																						
10	/																																																																																																								
12	/																																																																																																								
/	1/2"																																																																																																								
16	5/8"																																																																																																								
18	/																																																																																																								
/	3/4"																																																																																																								
20	/																																																																																																								
ODS mm	ODS inch	ODS mm	ODS inch																																																																																																						
4	/	22	/																																																																																																						
6	/	/	7/8"																																																																																																						
/	1/4"	28	/																																																																																																						
8	/	/	1 1/8"																																																																																																						
/	3/8"	35	1 3/8"																																																																																																						
10	/																																																																																																								
12	/	42	/																																																																																																						
/	1/2"	54	2 1/8"																																																																																																						
16	5/8"	64	/																																																																																																						
18	/	/	2 5/8"																																																																																																						
/	3/4"	76	/																																																																																																						
20	/	/	3 1/8"																																																																																																						
<table border="1"> <thead> <tr> <th>ROTALOCK</th> </tr> </thead> <tbody> <tr><td>3/4" -16 UNF</td></tr> <tr><td>1" -14 UNS</td></tr> <tr><td>1 1/4" -12 UNF</td></tr> <tr><td>1 1/2" -16 UN</td></tr> <tr><td>1 3/4" -12 UN</td></tr> <tr><td>2 1/4" -12 UN</td></tr> </tbody> </table> <p>RACCORDI ROTALOCK Rotalock connections</p> 	ROTALOCK	3/4" -16 UNF	1" -14 UNS	1 1/4" -12 UNF	1 1/2" -16 UN	1 3/4" -12 UN	2 1/4" -12 UN	<table border="1"> <thead> <tr> <th>ROTALOCK</th> </tr> </thead> <tbody> <tr><td>3/4" -16 UNF</td></tr> <tr><td>1" -14 UNS</td></tr> <tr><td>1 1/4" -12 UNF</td></tr> <tr><td>1 1/2" -16 UN</td></tr> <tr><td>1 3/4" -12 UN</td></tr> <tr><td>2 1/4" -12 UN</td></tr> </tbody> </table> <p>RACCORDI ROTALOCK CON PESCANTE Rotalock connections with deep tube</p> 	ROTALOCK	3/4" -16 UNF	1" -14 UNS	1 1/4" -12 UNF	1 1/2" -16 UN	1 3/4" -12 UN	2 1/4" -12 UN																																																																																										
ROTALOCK																																																																																																									
3/4" -16 UNF																																																																																																									
1" -14 UNS																																																																																																									
1 1/4" -12 UNF																																																																																																									
1 1/2" -16 UN																																																																																																									
1 3/4" -12 UN																																																																																																									
2 1/4" -12 UN																																																																																																									
ROTALOCK																																																																																																									
3/4" -16 UNF																																																																																																									
1" -14 UNS																																																																																																									
1 1/4" -12 UNF																																																																																																									
1 1/2" -16 UN																																																																																																									
1 3/4" -12 UN																																																																																																									
2 1/4" -12 UN																																																																																																									
<table border="1"> <thead> <tr> <th>ROTALOCK</th> </tr> </thead> <tbody> <tr><td>3/4" -16 UNF</td></tr> <tr><td>1" -14 UNS</td></tr> <tr><td>1 1/4" -12 UNF</td></tr> <tr><td>1 1/2" -16 UN</td></tr> <tr><td>1 3/4" -12 UN</td></tr> <tr><td>2 1/4" -12 UN</td></tr> </tbody> </table> <p>RUBINETTI ROTALOCK Rotalock Valves</p> 	ROTALOCK	3/4" -16 UNF	1" -14 UNS	1 1/4" -12 UNF	1 1/2" -16 UN	1 3/4" -12 UN	2 1/4" -12 UN	<table border="1"> <thead> <tr> <th>SAE</th> </tr> </thead> <tbody> <tr><td>1/4"</td></tr> <tr><td>3/8"</td></tr> <tr><td>1/2"</td></tr> <tr><td>5/8"</td></tr> <tr><td>3/4"</td></tr> </tbody> </table> <p>RACCORDI MASCHIO SAE SAE male connections</p> 	SAE	1/4"	3/8"	1/2"	5/8"	3/4"																																																																																											
ROTALOCK																																																																																																									
3/4" -16 UNF																																																																																																									
1" -14 UNS																																																																																																									
1 1/4" -12 UNF																																																																																																									
1 1/2" -16 UN																																																																																																									
1 3/4" -12 UN																																																																																																									
2 1/4" -12 UN																																																																																																									
SAE																																																																																																									
1/4"																																																																																																									
3/8"																																																																																																									
1/2"																																																																																																									
5/8"																																																																																																									
3/4"																																																																																																									
<table border="1"> <thead> <tr> <th>NPT</th> </tr> </thead> <tbody> <tr><td>1/8"</td></tr> <tr><td>1/4"</td></tr> <tr><td>3/8"</td></tr> <tr><td>1/2"</td></tr> <tr><td>3/4"</td></tr> <tr><td>1"</td></tr> <tr><td>1 1/4"</td></tr> </tbody> </table> <p>RACCORDI FEMMINA NPT NPT female connections</p> 	NPT	1/8"	1/4"	3/8"	1/2"	3/4"	1"	1 1/4"	<table border="1"> <thead> <tr> <th>O-RING</th> </tr> </thead> <tbody> <tr><td>1/4"</td></tr> <tr><td>3/8"</td></tr> <tr><td>1/2"</td></tr> <tr><td>5/8"</td></tr> <tr><td>3/4"</td></tr> </tbody> </table> <p>RACCORDI O-RING O-Ring connections</p> 	O-RING	1/4"	3/8"	1/2"	5/8"	3/4"																																																																																										
NPT																																																																																																									
1/8"																																																																																																									
1/4"																																																																																																									
3/8"																																																																																																									
1/2"																																																																																																									
3/4"																																																																																																									
1"																																																																																																									
1 1/4"																																																																																																									
O-RING																																																																																																									
1/4"																																																																																																									
3/8"																																																																																																									
1/2"																																																																																																									
5/8"																																																																																																									
3/4"																																																																																																									

RUBINETTI A SALDARE PER RICEVITORI
Soldering Valves for receivers

□ mm	ODS mm	ODS inch
□20	6	/
	/	1/4"
	8	/
	/	3/8"
	10	/
	12	/
	/	1/2"
	16	5/8"
18	/	
/	3/4"	

RUBINETTO ORIZZONTALE CON PRESA CENTRALE
Horizontal valve with central gage port

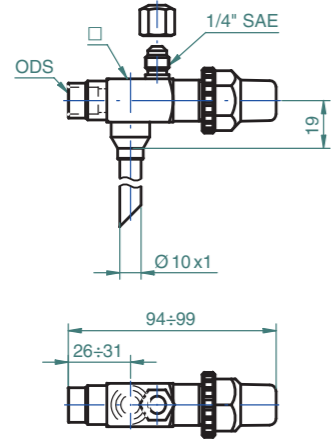

RUBINETTO VERTICALE CON PRESA SCHRADER CENTRALE
Vertical valve with central Schrader gage port

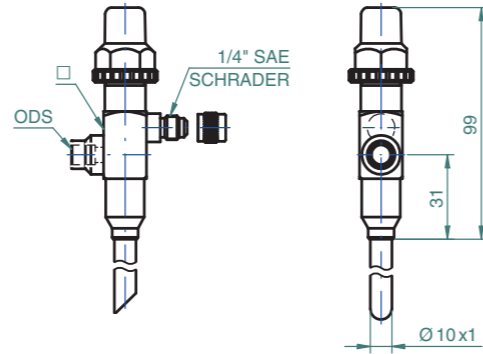

□ mm	SAE	O-RING
□20	1/4"	1/4"
	3/8"	3/8"
	1/2"	1/2"
	5/8"	5/8"
	3/4"	3/4"

RUBINETTO ORIZZONTALE CON PRESA SINISTRA E PRESA SCHRADER DESTRA IN BY-PASS
Horizontal valve with left gage port and right Schrader gage port at By-Pass

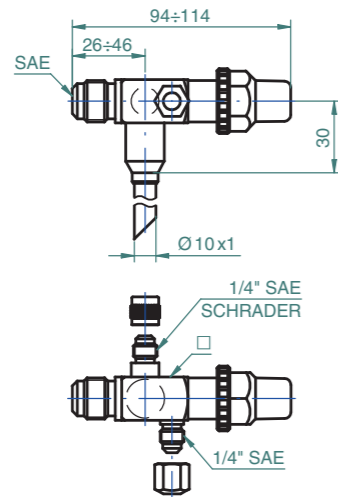

RUBINETTO VERTICALE CON ATTACCO O-RING E PRESA SINISTRA
Vertical valve with O-Ring connection and left gage port

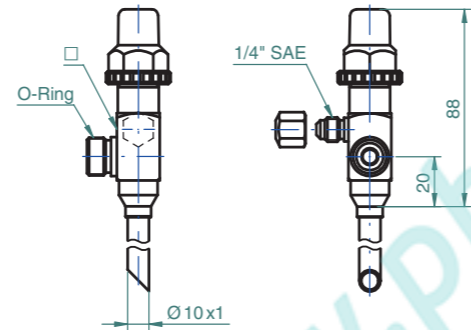

□ mm	ODS mm	ODS inch
□22	16	5/8"
	18	/
	22	3/4"
	/	7/8"

RUBINETTO ORIZZONTALE CON PRESA DESTRA E PRESA SCHRADER SINISTRA IN BY-PASS
Horizontal valve with right gage port and left Schrader gage port at By-Pass

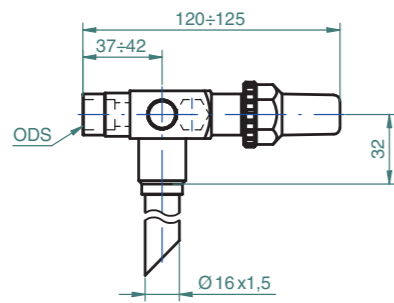

RUBINETTO ORIZZONTALE CON PRESA SINISTRA
Horizontal valve with left gage port

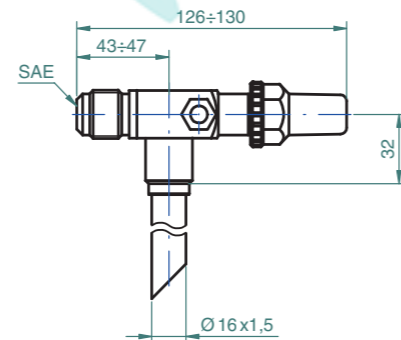

mm	SAE	O-RING
□22	5/8"	5/8"
	3/4"	3/4"

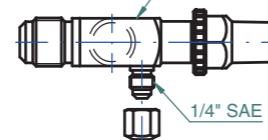
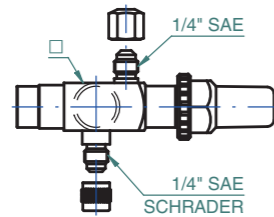

SEPARATORI DI LIQUIDO DA CALOTTE - Suction accumulators from caps

ØD mm	H1 mm	H2 mm	Volume liters	Category PED Fluids Group 2	ODS mm	ODS inch.	A MAX. mm
Ø77	160	197	0,60	Art. 3.3	10 - 12	3/8" - 1/2"	50
	180	217	0,70	Art. 3.3	10 - 12	3/8" - 1/2"	50
	205	242	0,75	Art. 3.3	10 - 12	3/8" - 1/2"	50
	225	262	0,85	Art. 3.3	10 - 12	3/8" - 1/2"	50
	280	317	1,10	Art. 3.3	10 - 12	3/8" - 1/2"	50
Ø100	160	205	1,00	Art. 3.3	12 - 16	1/2" - 5/8"	65
	180	225	1,10	Art. 3.3	12 - 16	1/2" - 5/8"	65
	200	245	1,20	Art. 3.3	12 - 16	1/2" - 5/8"	65
	220	265	1,40	Art. 3.3	12 - 16	1/2" - 5/8"	65
	240	285	1,50	Art. 3.3	12 - 16	1/2" - 5/8"	65
Ø120	270	315	1,70	Art. 3.3	12 - 16	1/2" - 5/8"	65
	333	378	2,10	Art. 3.3	12 - 16	1/2" - 5/8"	65
	190	235	1,60	Art. 3.3	16 - 18	5/8" - 3/4"	80
	250	295	2,20	Art. 3.3	16 - 18	5/8" - 3/4"	80
	330	375	2,50	Art. 3.3	16 - 18	5/8" - 3/4"	80
Ø125	342	387	3,50	Art. 3.3	16 - 18	5/8" - 3/4"	80
	265	310	2,80	Art. 3.3	16 - 18 - 22	5/8" - 3/4" - 7/8"	80
	280	325	2,90	Art. 3.3	16 - 18 - 22	5/8" - 3/4" - 7/8"	80
	315	360	3,40	Art. 3.3	16 - 18 - 22	5/8" - 3/4" - 7/8"	80
	365	410	4,00	Art. 3.3	16 - 18 - 22	5/8" - 3/4" - 7/8"	80
Ø150	305	350	4,40	Art. 3.3	18 - 22	3/4" - 7/8"	95
	360	405	5,30	Art. 3.3	18 - 22	3/4" - 7/8"	95
Ø160	265	310	4,20	Art. 3.3	18 - 22 - 28	3/4" - 7/8" - 1 1/8"	100
	345	390	5,70	Art. 3.3	18 - 22 - 28	3/4" - 7/8" - 1 1/8"	100
	420	465	7,00	Art. 3.3	18 - 22 - 28	3/4" - 7/8" - 1 1/8"	100
Ø180	270	315	5,40	Art. 3.3	22 - 28 - 35	7/8" - 1 1/8" - 1 3/8"	110
	330	375	6,80	Art. 3.3	22 - 28 - 35	7/8" - 1 1/8" - 1 3/8"	110
	395	440	8,30	Art. 3.3	22 - 28 - 35	7/8" - 1 1/8" - 1 3/8"	110
	325	380	8,10	Art. 3.3	22 - 28 - 35	7/8" - 1 1/8" - 1 3/8"	125
	350	405	8,80	Art. 3.3	22 - 28 - 35	7/8" - 1 1/8" - 1 3/8"	125
Ø200	375	430	9,60	Art. 3.3	22 - 28 - 35	7/8" - 1 1/8" - 1 3/8"	125
	365	420	11,0	Art. 3.3	28 - 35 - 42	1 1/8" - 1 3/8" - 1 5/8"	135
	360	415	15,0	Art. 3.3	35 - 42	1 3/8" - 1 5/8"	165
Ø260	420	475	18,0	Art. 3.3	35 - 42	1 3/8" - 1 5/8"	165
	455	510	22,0	Art. 3.3	42 - 54	1 5/8" - 2 1/8"	170

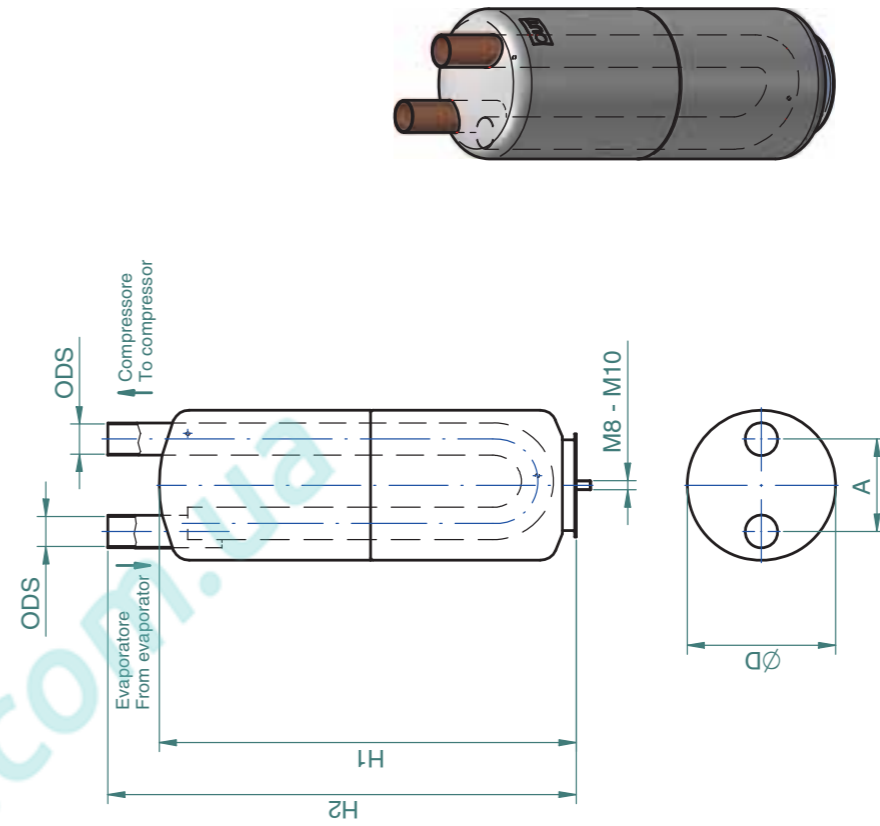

MASSIMA PRESSIONE DI LAVORO Maximum working pressure	PS 34 bar	PS 25 bar
TEMPERATURA AMMISSIBILE Permissible temperature	TS -10/+120°C	TS -40/+120°C
PRESSIONE DI COLLAUDO Testing pressure	PT 50 bar	
FLUIDO REFRIGERANTE Refrigerant	GROUP 2 PED	
COLORE Colour	BLACK RAL 9005	
RESISTENZA ALLA CORROSIONE IN NEBBIA SALINA DI 250 ORE SECONDO NORMA ASTM-B117. RESISTENZA FINO A 1000 ORE SU RICHIESTA. Corrosion resistance on salt spray at 250 hours according standard ASTM-B117. 1000 hours resistance on customer request.		
CONFORME ALLA DIRETTIVA 97/23/CE (PED) According to Directive 97/23/CE (PED)		

SEPARATORI DI LIQUIDO DA TUBO - Suction accumulators from tube

ØD mm	H1 mm	H2 mm	Volume liters	ODS mm	ODS inch	A mm	ØM mm	ØP mm	Category PED Fluids Group 2
Ø219,1	925	980	30	54 ÷ 64	2 1/8" ÷ 2 5/8"	110	204	Ø11	II
	1180	1235	39	54 ÷ 64	2 1/8" ÷ 2 5/8"	110	204	Ø11	III
	1610	1665	54	54 ÷ 64	2 1/8" ÷ 2 5/8"	110	204	Ø11	III
Ø273,0	1125	1190	56	64 ÷ 80	2 5/8" ÷ 3 1/8"	135	220	Ø13	III
	1445	1510	73	64 ÷ 80	2 5/8" ÷ 3 1/8"	135	220	Ø13	IV
	1745	1810	89	64 ÷ 80	2 5/8" ÷ 3 1/8"	135	220	Ø13	IV
Ø355,6	2045	2110	105	64 ÷ 80	2 5/8" ÷ 3 1/8"	135	220	Ø13	IV
	1325	1390	112	80 ÷ 108	3 1/8" ÷ 4 1/8"	175	350	Ø17	IV
	1855	1920	160	80 ÷ 108	3 1/8" ÷ 4 1/8"	175	350	Ø17	IV
Ø508,0	1340	1410	228	159	4 1/2" ÷ 5 1/2"	245	430	Ø19	IV
	1840	1910	320	159	4 1/2" ÷ 5 1/2"	245	430	Ø19	IV

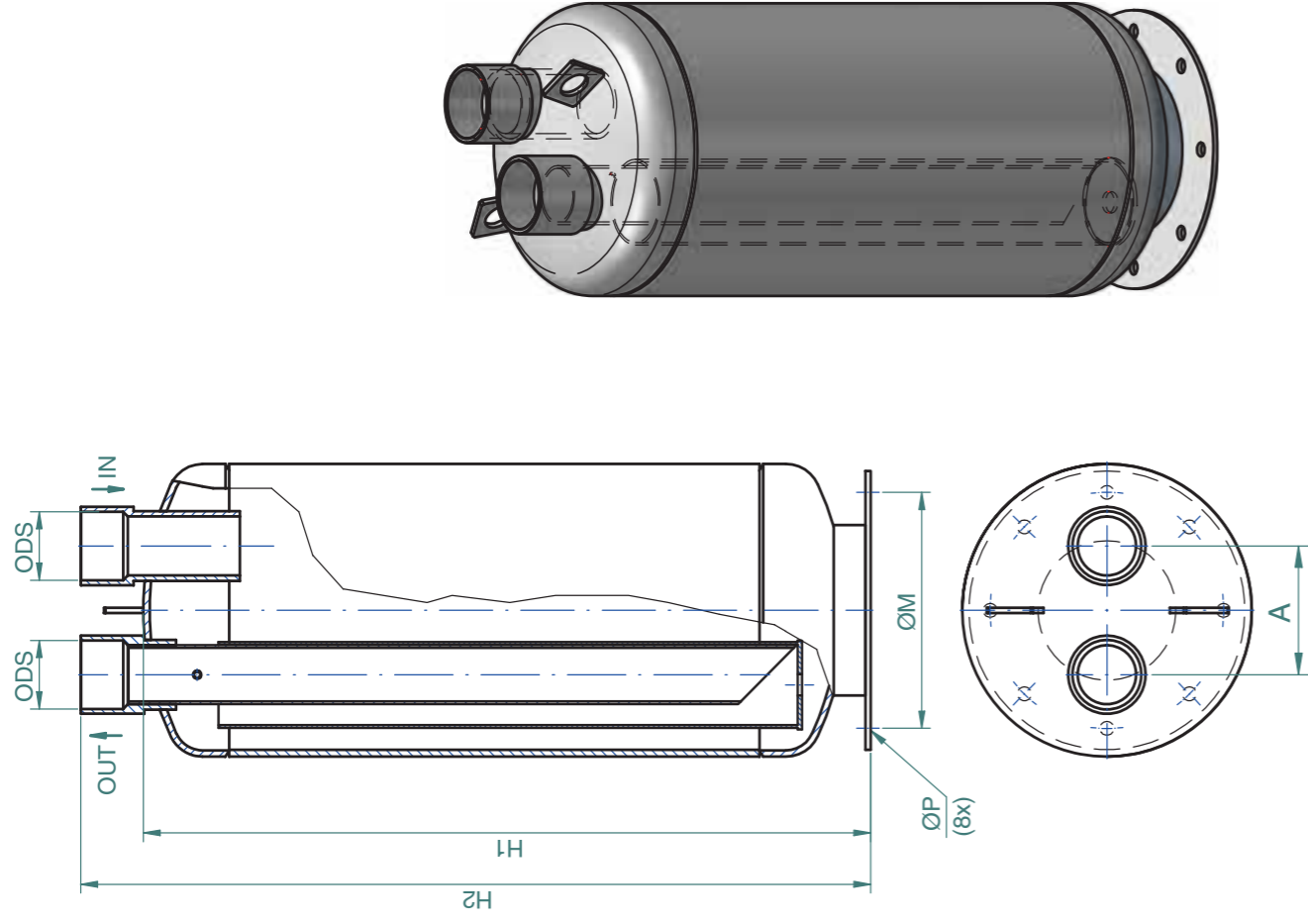

MASSIMA PRESSIONE DI LAVORO Maximum working pressure	PS 45 bar	PS 20 ÷ 33 bar
TEMPERATURA AMMISSIBILE Permissible temperature	TS -10/+120°C	TS -40/+120°C
PRESSIONE DI COLLAUDO Testing pressure	PT 65 bar	
COLORE Colour	BLACK RAL 9005	
RESISTENZA ALLA CORROSIONE IN NEBBIA SALINA DI 250 ORE SECONDO NORMA ASTM-B117. RESISTENZA FINO A 1000 ORE SU RICHIESTA. Corrosion resistance on salt spray at 250 hours according standard ASTM-B117. 1000 hours resistance on customer request.		
CONFORME ALLA DIRETTIVA 97/23/CE (PED) According to Directive 97/23/CE (PED)		

SEPARATORI DI LIQUIDO CON SCAMBIATORE DI CALORE - Suction accumulators with tube condenser

ØD mm	H mm	Volume liters	Category PED	ODS FREON		ODS COIL	
				mm	inch.	mm	inch.
Ø77	180	0,70	Art. 3.3	10 - 12	3/8" - 1/2"	6 - 8	1/4"
	225	0,85	Art. 3.3	10 - 12	3/8" - 1/2"	6 - 8	1/4"
Ø100	200	1,20	I	12 - 16 - 18	1/2" - 5/8"	8 - 10 - 12	3/8" - 1/2"
	240	1,50	I	12 - 16 - 18	1/2" - 5/8"	8 - 10 - 12	3/8" - 1/2"
Ø120	250	2,20	I	16 - 18	5/8" - 3/4"	10 - 12	1/2"
	330	2,50	I	16 - 18	5/8" - 3/4"	10 - 12	1/2"
Ø130	265	2,80	I	16 - 18	5/8" - 3/4"	10 - 12	1/2"
	315	3,40	I	16 - 18	5/8" - 3/4"	10 - 12	1/2"
	365	4,00	I	16 - 18	5/8" - 3/4"	10 - 12	1/2"
Ø160	265	4,20	I	18 - 22	3/4" - 7/8"	12 - 16	1/2" - 5/8"
	345	5,70	II	18 - 22	3/4" - 7/8"	12 - 16	1/2" - 5/8"
	420	7,00	II	18 - 22	3/4" - 7/8"	12 - 16	1/2" - 5/8"
Ø180	270	5,40	II	22 - 28	7/8" - 1 1/8"	16 - 18	5/8" - 3/4"
	330	6,80	II	22 - 28	7/8" - 1 1/8"	16 - 18	5/8" - 3/4"
	395	8,30	II	22 - 28	7/8" - 1 1/8"	16 - 18	5/8" - 3/4"
Ø200	325	8,10	II	22 - 28	7/8" - 1 1/8"	16 - 18	5/8" - 3/4"
	350	8,80	II	22 - 28	7/8" - 1 1/8"	16 - 18	5/8" - 3/4"
	375	9,60	II	22 - 28	7/8" - 1 1/8"	16 - 18	5/8" - 3/4"
Ø220	365	11,0	II	28 - 35	1 1/8" - 1 3/8"	18 - 22	3/4" - 7/8"
	360	15,0	II	28 - 35	1 1/8" - 1 3/8"	18 - 22	3/4" - 7/8"
Ø260	420	18,0	II	28 - 35	1 1/8" - 1 3/8"	18 - 22	3/4" - 7/8"
	455	22,0	II	35 - 42	1 3/8" - 1 5/8"	22 - 28	7/8" - 1 1/8"

Quote "A", "B", "C" da concordare.
Dimension "A", "B", "C" according to the agreement.

MASSIMA PRESSIONE DI LAVORO Maximum working pressure	PS 45 bar	PS 20 ÷ 33 bar
TEMPERATURA AMMISSIBILE Permissible temperature	TS -10/+120°C	TS -40/+120°C
PRESSIONE DI COLLAUDO Testing pressure	PT 65 bar	
FLUIDO REFRIGERANTE Refrigerant	GROUP 2 PED	
COLORE Colour	BLACK RAL 9005	
RESISTENZA ALLA CORROSIONE IN NEBBIA SALINA DI 250 ORE SECONDO NORMA ASTM-B117. RESISTENZA FINO A 1000 ORE SU RICHIESTA. Corrosion resistance on salt spray at 250 hours according standard ASTM-B117. 1000 hours resistance on customer request.		
CONFORME ALLA DIRETTIVA 97/23/CE (PED) According to Directive 97/23/CE (PED)		

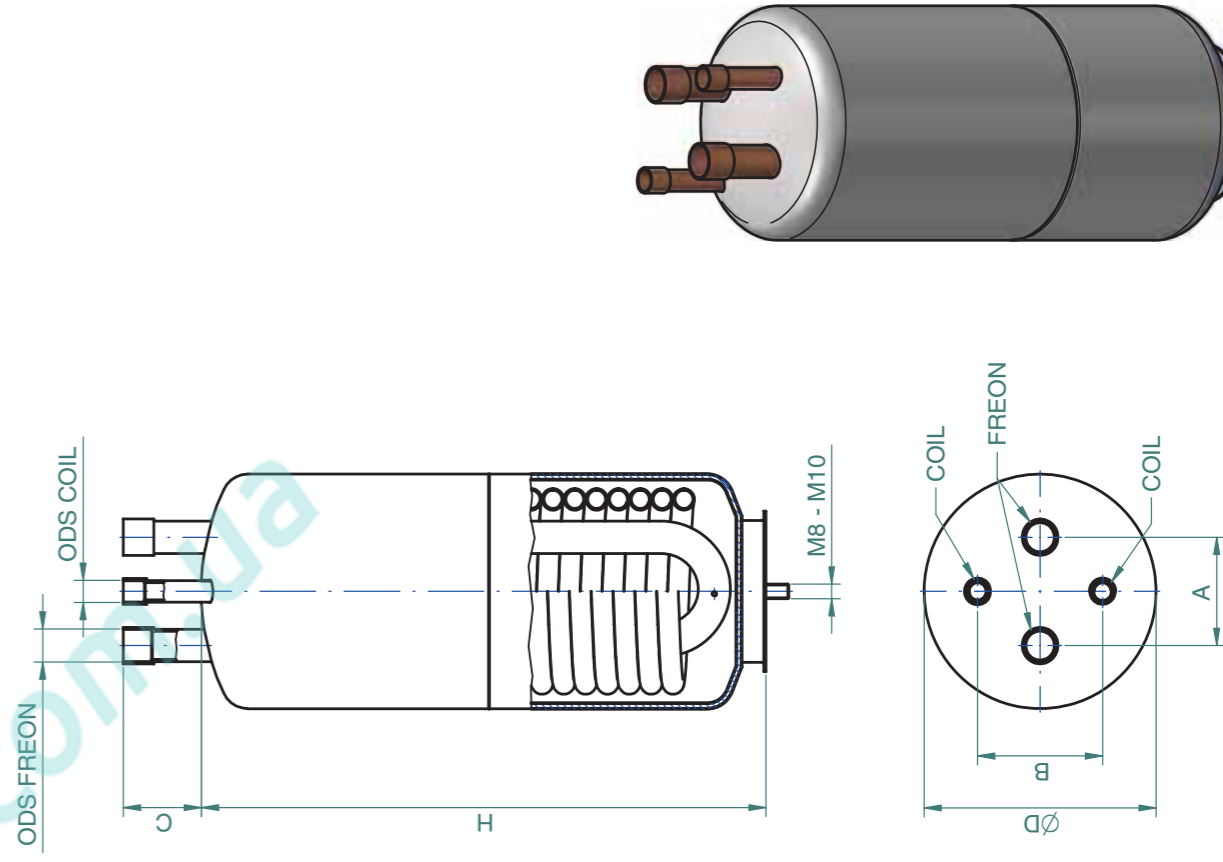

SEPARATORI DI LIQUIDO PER CO2 (R744) - Suction accumulators for CO2 (R744)

ØD mm	H1 mm	H2 mm	Volume liters	Category PED Fluids Group 2	ØDS mm	ØDS inch.	A MAX. mm
Ø101,6	277	322	1,80	II	10 - 12	3/8" - 1/2"	65
	310	355	2,00	II	10 - 12	3/8" - 1/2"	65
	430	475	2,80	II	16 - 18	5/8" - 3/4"	60
	460	505	3,00	II	16 - 18	5/8" - 3/4"	60
	844	889	5,70	II	18 - 22	3/4" - 7/8"	55
Ø121,0	335	380	3,00	II	16 - 18	5/8" - 3/4"	75
	510	555	4,70	II	16 - 18	5/8" - 3/4"	75
	555	600	5,20	II	18 - 22	3/4" - 7/8"	75
	670	715	6,30	II	18 - 22	3/4" - 7/8"	75
	493	538	6,00	II	18 - 22	3/4" - 7/8"	90
Ø139,7	660	705	8,30	III	22 - 28	7/8" - 1 1/8"	80
	865	910	11,0	III	28 - 35	1 1/8" - 1 3/8"	75
	520	565	9,10	III	22 - 28	7/8" - 1 1/8"	105
	620	665	11,0	III	28 - 35	1 1/8" - 1 3/8"	100
	655	700	11,8	III	28 - 35	1 1/8" - 1 3/8"	100
Ø168,3	745	790	13,5	III	28 - 35	1 1/8" - 1 3/8"	100
	790	845	14,3	III	35 - 42	1 3/8" - 1 5/8"	90
	995	1050	18,3	III	35 - 42	1 3/8" - 1 5/8"	90
	475	530	13,5	III	28 - 35	1 1/8" - 1 3/8"	140
	500	555	14,3	III	35 - 42	1 3/8" - 1 5/8"	130
Ø219,1	590	645	17,3	III	35 - 42	1 3/8" - 1 5/8"	130
	725	780	21,6	III	35 - 42	1 3/8" - 1 5/8"	130
	780	835	23,4	IV	42 - 54	1 5/8" - 2 1/8"	120
	925	980	28,1	IV	42 - 54	1 5/8" - 2 1/8"	120
	975	1030	29,7	IV	42 - 54	1 5/8" - 2 1/8"	120
	1180	1235	36,4	IV	54	2 1/8"	120

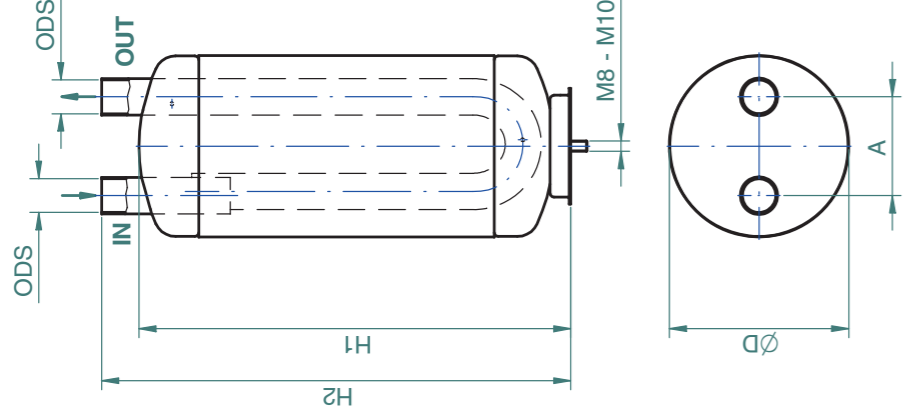

MASSIMA PRESSIONE DI LAVORO Maximum working pressure	PS 130 bar
TEMPERATURA AMMISSIBILE Permissible temperature	TS -10/+120°C
PRESSIONE DI COLLAUDO Testing pressure	PT 186 bar
FLUIDO REFRIGERANTE Refrigerant	GROUP 2 PED
COLORE Colour	BLACK RAL 9005
RESISTENZA ALLA CORROSIONE IN NEBBIA SALINA DI 250 ORE SECONDO NORMA ASTM-B117. RESISTENZA FINO A 1000 ORE SU RICHIESTA. Corrosion resistance on salt spray at 250 hours according standard ASTM-B117. 1000 hours resistance on customer request.	
CONFORME ALLA DIRETTIVA 97/23/CE (PED) According to Directive 97/23/CE (PED)	

RICEVITORI D'OLIO - Oil Receivers

ØD mm	H mm	Volume liters	Category PED Fluids Group 2
Ø130	384	8,3	I
Ø160	332	5,7	II
	407	7,0	II
Ø180	384	8,3	II
Ø220	350	11,0	II

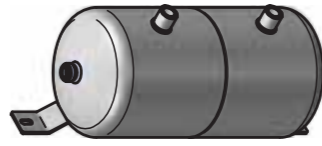
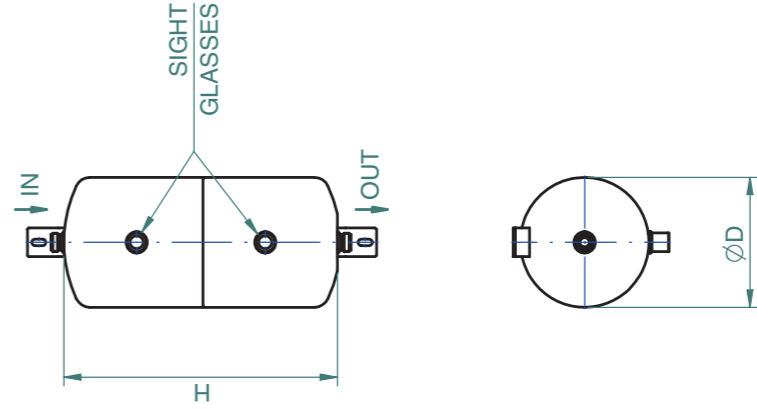

ØD mm	H1 mm	H2 mm	Volume liters	Category PED Fluids Group 2
Ø139,7	483	557	6,5	II
	650	724	8,8	II
	486	560	8,5	II
Ø159,0	548	622	9,7	II
	721	795	12	II
	605	679	12	II
Ø168,3	730	804	14,6	II
	775	849	15,5	II
	611	685	20	II
Ø219,1	760	834	25	III
	900	974	30	III
	622	696	30	III

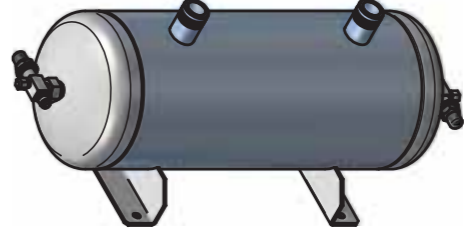
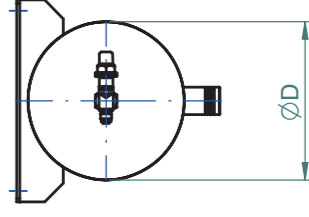
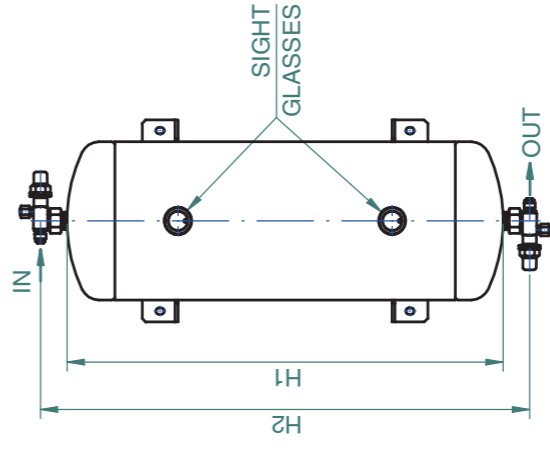

MASSIMA PRESSIONE DI LAVORO Maximum working pressure	PS 45 bar	PS 20 ÷ 33 bar
TEMPERATURA AMMISSIBILE Permissible temperature	TS -10/+120°C	TS -40/+120°C
PRESSIONE DI COLLAUDO Testing pressure	PT 65 bar	PT 65 bar
COLORE Colour	BLACK RAL 9005	
RESISTENZA ALLA CORROSIONE IN NEBBIA SALINA DI 250 ORE SECONDO NORMA ASTM-B117. RESISTENZA FINO A 1000 ORE SU RICHIESTA. Corrosion resistance on salt spray at 250 hours according standard ASTM-B117. 1000 hours resistance on customer request.		
CONFORME ALLA DIRETTIVA 97/23/CE (PED) According to Directive 97/23/CE (PED)		

INDICATORE DI LIVELLO A SALDARE CON TECNOLOGIA BREVETTATA.
Sight Glass soldered with patented technology.

Øi 28mm - Øe 38mm
Øi 18mm - Øe 26mm

RICEVITORI D'OLIO - Oil Receivers - CO₂ (R744)

ØD mm	H1 mm	H2 mm	90 bar		130 bar	
			Volume liters	Category PED	Volume liters	Category PED
Ø139,7	350	424	4,30	II	4,00	II
	483	557	6,00	II	5,70	II
	650	724	8,30	II	7,60	II
	855	929	11,0	II	10,3	III
Ø168,3	440	514	7,90	II	7,50	II
	505	579	9,10	II	8,70	III
	605	679	11,0	II	10,5	III
	640	714	11,8	III	11,1	III
	730	804	13,5	III	12,8	III
	775	849	14,3	III	13,6	III
Ø219,1	980	1054	18,3	III	17,3	III
	1302	1376	24,5	III	23,0	III
	320	394	9,30	III	8,80	III
	450	524	13,5	III	12,7	III
	475	549	14,3	III	13,5	III
	565	639	17,3	III	16,2	III
	700	774	21,6	III	20,4	III
	755	829	23,4	III	22,0	III
	900	974	28,1	III	26,5	IV
	950	1024	29,7	III	28,0	IV

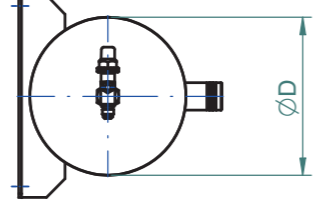
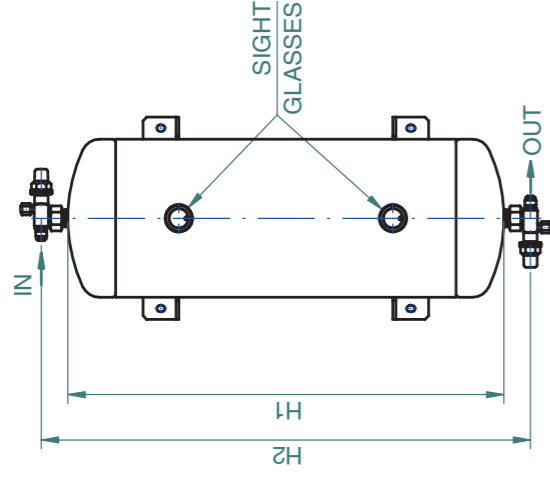
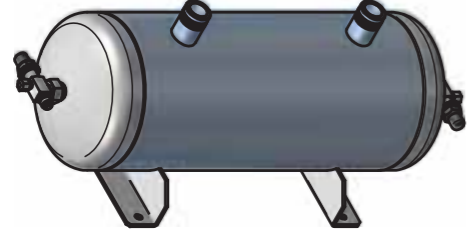

MASSIMA PRESSIONE DI LAVORO Maximum working pressure	PS 90 bar	PS 130 bar
PRESSIONE DI COLLAUDO Testing pressure	PT 128,7 bar	PT 185,9 bar
TEMPERATURA AMMISSIBILE Permissible temperature	TS -30/+120°C	
FLUIDO REFRIGERANTE Refrigerant	GROUP 2 PED	
COLORE Colour	BLACK RAL 9005	
DIMENSIONE RACCORDI Connections Dimension	A RICHIESTA DEL CLIENTE On customer request	
RESISTENZA ALLA CORROSIONE IN NEBBIA SALINA DI 250 ORE SECONDO NORMA ASTM-B117. RESISTENZA FINO A 1000 ORE SU RICHIESTA. Corrosion resistance on salt spray at 250 hours according standard ASTM-B117. 1000 hours resistance on customer request.		
CONFORME ALLA DIRETTIVA 97/23/CE (PED) According to Directive 97/23/CE (PED)		

INDICATORE DI LIVELLO A SALDARE CON TECNOLOGIA BREVETTATA. Sight Glass soldered with patented technology.	
INDICATORE DI LIVELLO AD AVVITARE. Sight Glass screwed.	

SILENZIATORI - Mufflers

ØD mm	Volume liters	H1 mm	H2 mm	ØDS mm	ØDS inch.	O-RING	CATEGORY PED
Ø 60	0,2	93	155	10 - 12	3/8" - 1/2"	1/4" - 3/8"	Art. 3.3
Ø 77	0,6	160	240	16 - 18	5/8" - 3/4"	1/4" - 3/8"	Art. 3.3
Ø 100	1,2	187	267	22 - 28	7/8" - 1 1/8"	3/8" - 1/2"	I
Ø 120	1,6	181	281	35 - 42	1 3/8" - 1 5/8"	1/2" - 5/8"	I
Ø 120	2,2	239	339	35 - 42	1 3/8" - 1 5/8"	1/2" - 5/8"	I
Ø 150	4,4	294	394	42 - 54	2 1/8"	5/8" - 3/4"	I
Ø 150	5,3	349	449	42 - 54	2 1/8"	5/8" - 3/4"	II
Ø 160	5,7	332	452	64	2 5/8"	3/4"	II
Ø 160	7,0	407	527	64	2 5/8"	3/4"	II

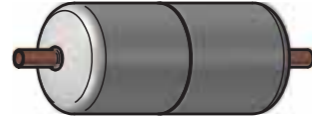
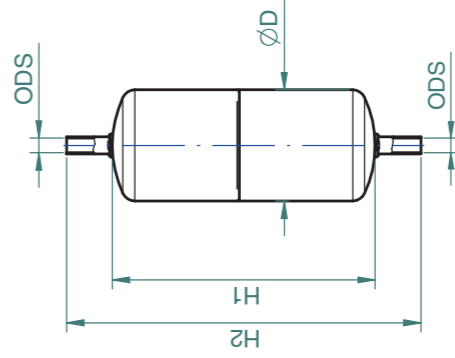

SILENZIATORI PER CO₂ (R744) - CO₂ (R744) Mufflers

ØD mm	Volume liters	H1 mm	H2 mm	ØDS mm	ØDS inch.	CATEGORY PED
Ø 76,1	0,5	130	190	10	3/8"	Art. 3.3
Ø 76,1	1,3	340	400	12	1/2"	I
Ø 76,1	1,5	400	460	12	1/2"	I
Ø 101,6	1,8	267	347	16	5/8"	I
Ø 101,6	2,0	300	380	16	5/8"	I
Ø 101,6	2,8	420	500	18	3/4"	I
Ø 101,6	3,0	450	530	18	3/4"	I
Ø 139,7	4,3	350	450	22	7/8"	I

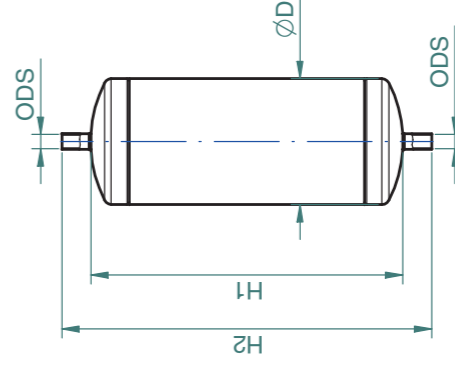

MASSIMA PRESSIONE DI LAVORO Maximum working pressure	PS 45 bar	PS 20-33 bar
TEMPERATURA AMMISSIBILE Permissible temperature	TS -10/+120°C	TS -40/+120°C
PRESSIONE DI COLLAUDO Testing pressure	PT 65 bar	
FLUIDO REFRIGERANTE Refrigerant	GROUP 2 PED	
COLORE Colour	BLACK RAL 9005	
RESISTENZA ALLA CORROSIONE IN NEBBIA SALINA DI 250 ORE SECONDO NORMA ASTM-B117. RESISTENZA FINO A 1000 ORE SU RICHIESTA. Corrosion resistance on salt spray at 250 hours according standard ASTM-B117. 1000 hours resistance on customer request.		
CONFORME ALLA DIRETTIVA 97/23/CE (PED) According to Directive 97/23/CE (PED)		

MASSIMA PRESSIONE DI LAVORO Maximum working pressure	PS 130 bar
TEMPERATURA AMMISSIBILE Permissible temperature	TS -30/+120°C
PRESSIONE DI COLLAUDO Testing pressure	PT 186 bar
FLUIDO REFRIGERANTE Refrigerant	GROUP 2 PED
COLORE Colour	BLACK RAL 9005
RESISTENZA ALLA CORROSIONE IN NEBBIA SALINA DI 250 ORE SECONDO NORMA ASTM-B117. RESISTENZA FINO A 1000 ORE SU RICHIESTA. Corrosion resistance on salt spray at 250 hours according standard ASTM-B117. 1000 hours resistance on customer request.	
CONFORME ALLA DIRETTIVA 97/23/CE (PED) According to Directive 97/23/CE (PED)	

SEPARATORI D'OLIO - Oil Separators

ØD mm	Vol L	MAX RISERVA D'OLIO Max oil reservation L	H mm	A	B	POTENZA FRIGORIFERA (W) ALL'EVAPORATORE (VALORI INDICATIVI) Cooling power (W) at the evaporator (INDICATIVE VALUES)				PRECARICA D'OLIO Oil precharge ml	PORTATA VOLUMETRICA COMPRESSORE INDICATIVA Approximate compressor displacement ml/h		
						R134a		R404A ÷ R507				R407C ÷ R410A	
						-40 °C	+5 °C	-40 °C	+5 °C			-40 °C	+5 °C
Ø77	0,40	0,20	110	3/8" SAE	1/4" SAE	400	7500	1000	8500	600	8000	35	4 ÷ 8
						600	8000	1500	9000	1000	8500	35	4 ÷ 8
						400	7500	1000	8500	600	8000	35	4 ÷ 8
Ø77	0,45	0,25	117	1/2" O-RING	1/4" SAE	1000	8500	2000	9500	1500	9000	35	4 ÷ 8
						1000	8500	2000	9500	1500	9000	35	4 ÷ 8
						1000	8500	2000	9500	1500	9000	35	4 ÷ 8
Ø77	0,50	0,30	128	5/8" O-RING	1/4" SAE	1500	10000	2500	11000	2800	10500	25	4 ÷ 8
						1500	10000	2500	11000	2800	10500	25	4 ÷ 8
						1500	10000	2500	11000	2800	10500	25	4 ÷ 8
Ø77	0,70	0,50	178	5/8" O-RING	1/4" SAE	1900	10500	2800	11500	3200	11000	35	4 ÷ 8
						1900	10500	2800	11500	3200	11000	35	4 ÷ 8
						1900	10500	2800	11500	3200	11000	35	4 ÷ 8
Ø100	1,1	0,70	180	5/8" SAE	1/4" SAE	2500	11500	3500	12000	4000	12000	60	8 ÷ 14
						2500	11500	3500	12000	4000	12000	60	8 ÷ 14
						2500	11500	3500	12000	4000	12000	60	8 ÷ 14
Ø100	1,7	1,1	270	5/8" SAE	1/4" SAE	3000	12000	3800	14000	4500	12500	60	8 ÷ 14
						3000	12000	3800	14000	4500	12500	60	8 ÷ 14
						3000	12000	3800	14000	4500	12500	60	8 ÷ 14

MASSIMA PRESSIONE DI LAVORO Maximum working pressure	PS 20 ÷ 45 bar
TEMPERATURA AMMISSIBILE Permissible temperature	TS -40/+120°C
PRESSIONE DI COLLAUDO Testing pressure	PT = PS x 1,43 (bar)
COLORE Colour	BLACK RAL 9005
RESISTENZA ALLA CORROSIONE IN NEBBIA SALINA DI 250 ORE SECONDO NORMA ASTM-B117. Corrosion resistance on salt spray at 250 hours according standard ASTM-B117. 1000 hours resistance on customer request.	

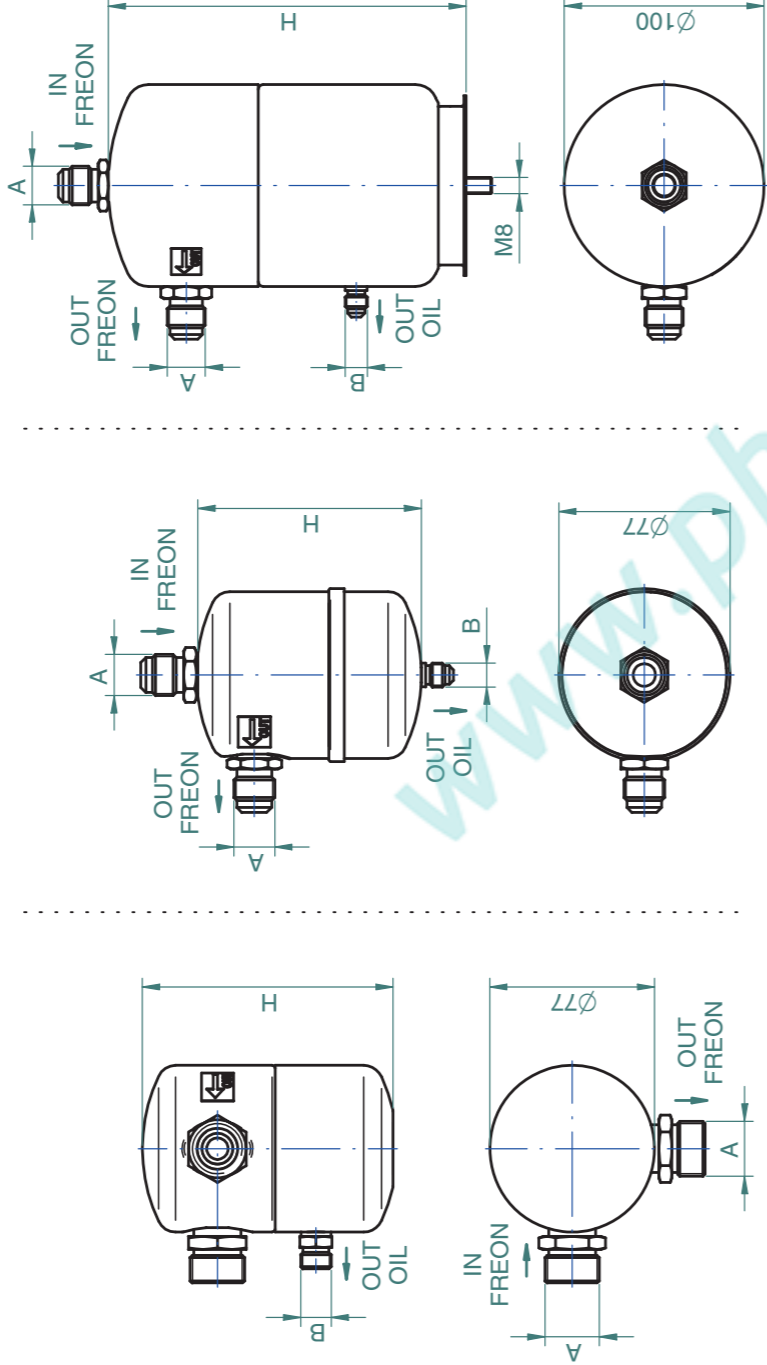
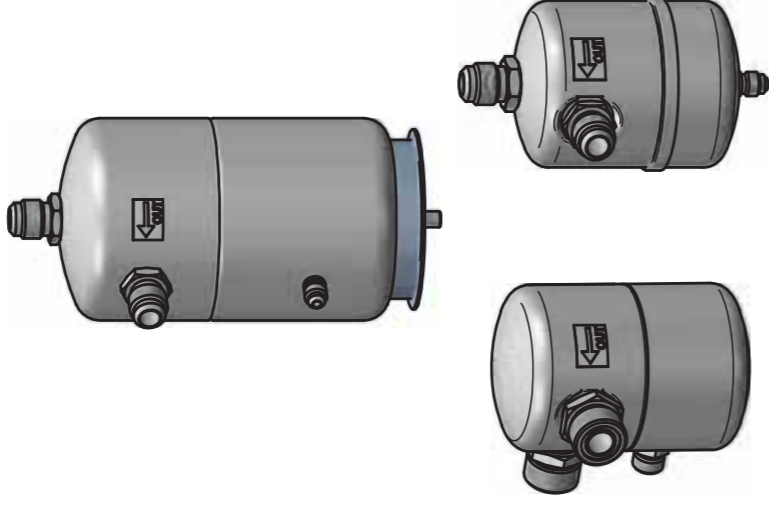

SEPARATORI D'OLIO CON RISERVA D'OLIO E POTENZA FRIGORIFERA MAGGIORE A 14KW ALL'EVAPORATORE - Oil Separators with oil reservation and higher then 14KW cooling power at the evaporator

Vol L	MAX RISERVA D'OLIO Max oil reservation L	ØD mm	H mm	ODS FREON IN - OUT		OUT OIL		POTENZA FRIGORIFERA (KW) ALL'EVAPORATORE (VALORI INDICATIVI) Cooling power (KW) at the evaporator (INDICATIVE VALUES)				PRECARICA D'OLIO Oil precharge L	PORTATA VOLUMETRICA COMPRESSORE INDICATIVA Approximate compressor displacement ml/h	NPT		
				mm	inch.	ROTALOCK	ODS mm	R134a		R404A ÷ R507					R407C ÷ R410A - R22	
								-30 °C	+5 °C	-30 °C	+5 °C				-30 °C	+5 °C
3,4	1,15	Ø130	315	5/8"	16	1" -14 UNS	16	10	15	20	15	14	17	0,20	3/8"	
3,4	1,15	Ø130	315	7/8"	16	1" -14 UNS	16	23	30	35	27	24	30	0,20	3/8"	
3,4	1,15	Ø130	315	1 1/8"	16	1" -14 UNS	16	27	35	40	30	30	38	0,20	3/8"	
5,3	2,20	Ø150	360	5/8"	16	1" -14 UNS	22	28	37	42	31	29	37	0,30	3/8"	
5,3	2,20	Ø150	360	7/8"	22	1" -14 UNS	22	32	42	50	38	35	45	0,30	3/8"	
5,3	2,20	Ø150	360	1 1/8"	22	1" -14 UNS	22	37	49	58	44	40	49	0,30	3/8"	
5,3	2,20	Ø150	360	1 3/8"	35	1" -14 UNS	22	43	56	67	50	46	56	0,30	3/8"	
7,0	3,90	Ø160	420	1 1/8"	28	1 1/4" -12 UNF	28	44	58	75	58	52	64	0,40	3/8"	
7,0	3,90	Ø160	420	1 3/8"	35	1 1/4" -12 UNF	28	49	64	83	65	58	70	0,40	3/8"	
7,0	3,90	Ø160	420	1 5/8"	42	1 1/4" -12 UNF	28	56	73	85	65	60	75	0,40	3/8"	
7,0	3,90	Ø160	420	2 1/8"	54	1 1/4" -12 UNF	28	64	84	98	70	70	88	0,40	3/8"	
11,0	4,90	Ø220	365	42	42	1 1/4" -12 UNF	35	85	110	140	105	100	125	1,00	1/2"	
11,0	4,90	Ø220	365	54	54	1 1/4" -12 UNF	35	98	125	160	120	116	142	1,00	1/2"	
15,0	6,60	Ø260	360	54	54	1 1/4" -12 UNF	35	110	140	180	160	150	185	1,50	1/2"	
15,0	6,60	Ø260	360	67	67	1 1/4" -12 UNF	35	145	190	210	280	200	260	1,50	1/2"	
22,0	10,5	Ø280	455	67	67	1 1/4" -12 UNF	42	110	140	210	160	150	185	1,50	1/2"	
22,0	10,5	Ø280	455	80	80	1 1/4" -12 UNF	42	145	190	280	210	200	260	1,50	1/2"	

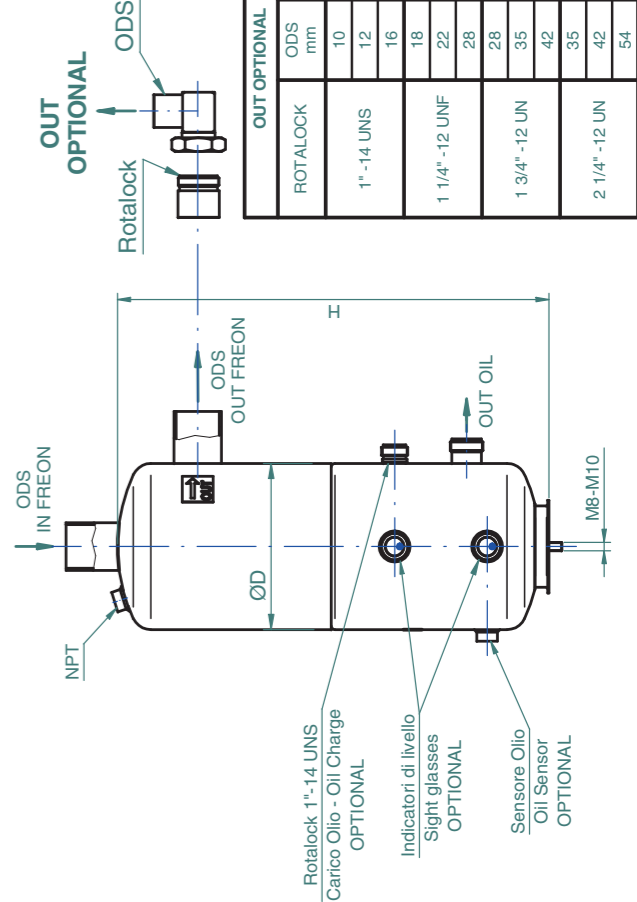

OUT OPTIONAL	
ROTALOCK	ODS inch.
1" -14 UNS	3/8"
1 1/4" -12 UNF	1/2"
1 1/4" -12 UNF	5/8"
1 3/4" -12 UN	3/4"
2 1/4" -12 UN	7/8"
2 1/4" -12 UN	1 1/8"
2 1/4" -12 UN	1 3/8"
2 1/4" -12 UN	1 5/8"
2 1/4" -12 UN	2 1/8"

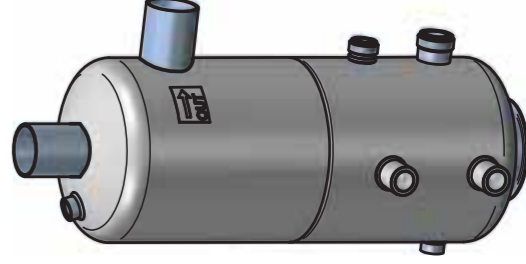

OUT OIL OPTIONAL:
CON RUBINETTO SALDATO
With soldered valve

MASSIMA PRESSIONE DI LAVORO Maximum working pressure	PS 20 ÷ 45 bar
TEMPERATURA AMMISSIBILE Permissible temperature	TS -40/+120°C
PRESSIONE DI COLLAUDO Testing pressure	PT = PS x 1,43 (bar)
COLORE Colour	BLACK RAL 9005
RESISTENZA ALLA CORROSIONE IN NEBBIA SALINA DI 250 ORE SECONDO NORMA ASTM-B117. RESISTENZA FINO A 1000 ORE SU RICHIESTA. Corrosion resistance on salt spray at 250 hours according standard ASTM-B117. 1000 hours resistance on customer request.	

SEPARATORI D'OLIO DA TUBO CON RISERVA D'OLIO E PER PORTATE VOLUMETRICHE DEL COMPRESSORE DA 75 A 300 m³/h - Oil Separators from tube with oil reserve for compressor displacement from 75 to 300 m³/h

Volume L	MAX RISERVA OLIO Max oil reservation L	ØD mm	H mm	ODS FREON IN - OUT		OUT OIL		ATTACCO ROTALOCK CARICO OLIO Oil charge connection	ATTACCO SENSORE OLIO Oil sensor connection	INDICATORE DI LIVELLO Sight-glass	PRECARICA OLIO Oil precharge	PORTATA VOLUMETRICA INDICATIVA COMPRESSORE Approximate compressor displacement	
				mm	inch.	mm	Rotalock					H3 mm	m³/h
35	12,3	273,0	690	54 - 67 - 80	2 1/8" - 2 5/8" - 3 1/8"	490	1 1/4" - 12 UNF	135	1/2" NPT	H2 mm	L	75	120
50	15,5	323,9	675	67 - 80	2 5/8" - 3 1/8"	470	1 1/4" - 12 UNF	200	1/2" NPT	200	4,0	120	200
89	40,5	406,4	800	67 - 80	2 5/8" - 3 1/8"	560	1 1/4" - 12 UNF	225	1/2" NPT	325	6,0	200	300

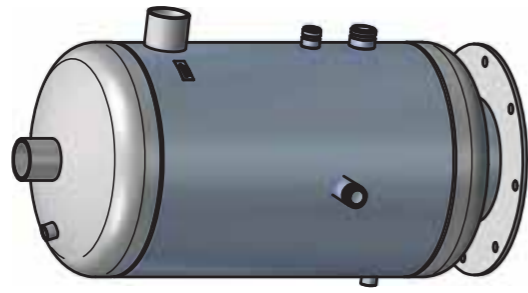
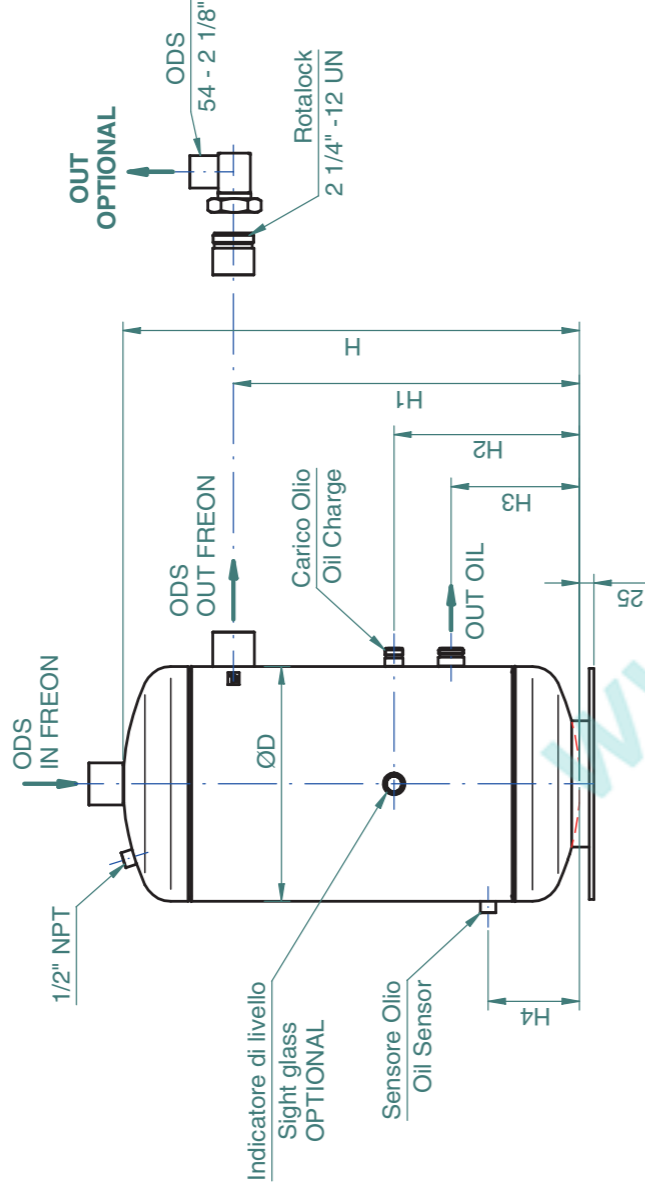

MASSIMA PRESSIONE DI LAVORO Maximum working pressure	PS 20 ÷ 33 bar
TEMPERATURA AMMISSIBILE Permissible temperature	TS -10/+100°C
PRESSIONE DI COLLAUDO Testing pressure	PT = PS x 1,43 (bar)
COLORE Colour	BLACK RAL 9005
RESISTENZA ALLA CORROSIONE IN NEBBIA SALINA DI 250 ORE SECONDO NORMA ASTM-B117. RESISTENZA FINO A 1000 ORE SU RICHIESTA. Corrosion resistance on salt spray at 250 hours according standard ASTM-B117. 1000 hours resistance on customer request.	

OUT OIL OPTIONAL:
CON RUBINETTO ROTALOCK
With Rotalock valve

SEPARATORI D'OLIO PER COMPRESSORI COLLEGATI IN PARALLELO - Oil Separators with compressors connected in parallel

Volume L	MAX RISERVA OLIO Max oil reservation L	ØD mm	H mm	ODS FREON IN - OUT		OUT OIL		ATTACCO ROTALOCK CARICO OLIO Oil charge connection	ATTACCO SENSORE OLIO Oil sensor connection	INDICATORE DI LIVELLO Sight-glass	RESISTENZE ELETTRICHE Electrical resistors	PRECARICA OLIO Oil precharge	PORTATA VOLUMETRICA INDICATIVA COMPRESSORE Approximate compressor displacement	
				mm	inch.	mm	Rotalock						H3 mm	N°
50	15,5	323,9	675	54 - 67 - 80	2 1/8" - 2 5/8" - 3 1/8"	470	1 1/4" - 12 UNF	200	1/2" NPT	H2 mm	2	45	120	200
89	40,5	406,4	800	67 - 80	2 5/8" - 3 1/8"	560	1 1/4" - 12 UNF	225	1/2" NPT	325	3	65	200	300
160	65	508,0	1000	67 - 80	2 5/8" - 3 1/8"	720	1 1/4" - 12 UNF	275	1/2" NPT	350	3	90	300	500
310	133	508,0	1800	120	4 3/4" - 5"	1500	1 3/4" - 12 UN	275	1/2" NPT	700	4	90	500	700

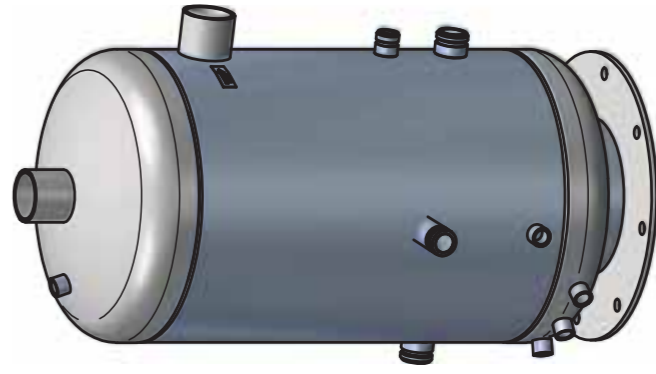
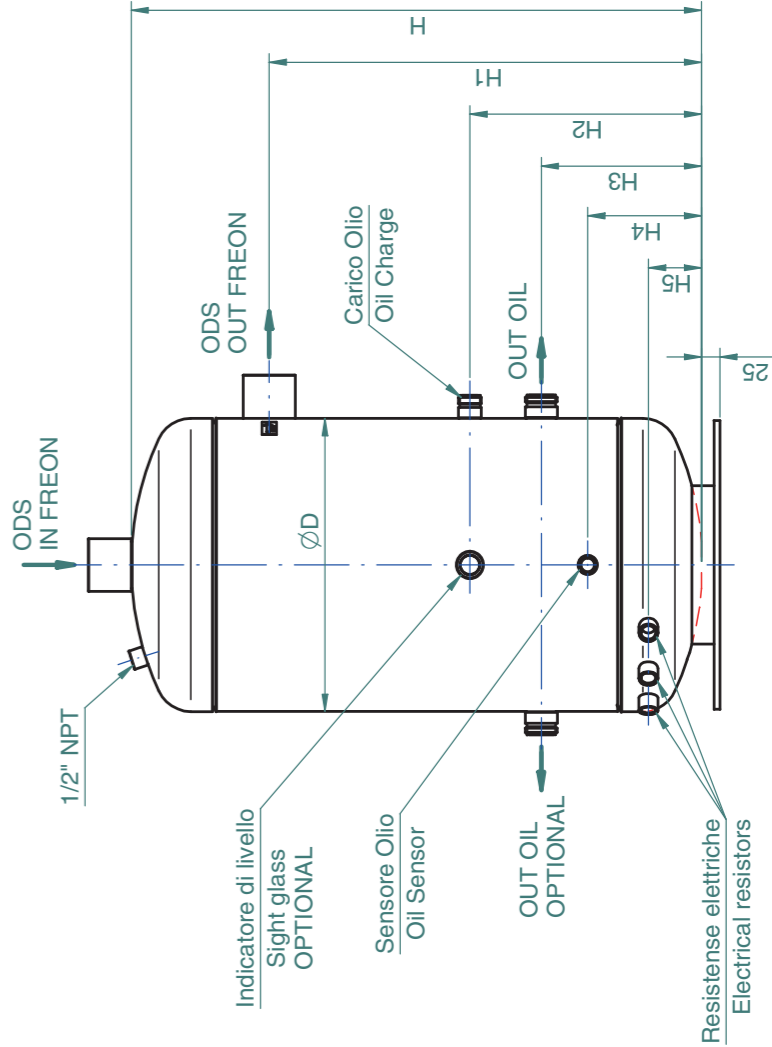

MASSIMA PRESSIONE DI LAVORO Maximum working pressure	PS 20 ÷ 33 bar
TEMPERATURA AMMISSIBILE Permissible temperature	TS -10/+100°C
PRESSIONE DI COLLAUDO Testing pressure	PT = PS x 1,43 (bar)
COLORE Colour	BLACK RAL 9005
RESISTENZA ALLA CORROSIONE IN NEBBIA SALINA DI 250 ORE SECONDO NORMA ASTM-B117. RESISTENZA FINO A 1000 ORE SU RICHIESTA. Corrosion resistance on salt spray at 250 hours according standard ASTM-B117. 1000 hours resistance on customer request.	

OUT OIL OPTIONAL:
CON RUBINETTO ROTALOCK
With Rotalock valve

SEPARATORI D'OLIO PER CO2 (130 bar) - Oil Separators for CO2 (130 bar)

Volume L	MAX RISERVA OLIO Max oil reservation L	ØD mm	H mm	H1 mm	ODS FREON IN - OUT		OUT OIL		ATTACCO SENSORE OLIO Oil sensor connection		ATTACCO ROTALOCK CARICO OLIO Oil charge connection		INDICATORI DI LIVELLO Sight glass		PRECARICA OLIO Oil precharge	PORTATA VOLUMETRICA INDICATIVA COMPRESSORE Approximate compressor displacement	NPT
					mm	inch.	H2 mm	Rotalock / SAE	NPT	H4 mm	1/2" NPT	H3 mm	H4 mm	H3 mm			
2,8	1,0	121	337	325	16	5/8"	245	1/4" SAE	/	90	110	110	90	110	0,2	8 ÷ 14	1/4"
4,0	1,6	139,7	362	350	18	3/4"	260	3/4"-16 UNF	1/4"	100	140	140	100	140	0,3	14 ÷ 20	3/8"
7,5	3,0	168,3	454	440	22	7/8"	345	3/4"-16 UNF	1/4"	110	160	160	110	160	0,4	20 ÷ 35	3/8"
12,7	5,0	219,1	475	450	28	1 1/8"	350	3/4"-16 UNF	1/4"	140	160	160	140	160	1,0	35 ÷ 60	1/2"

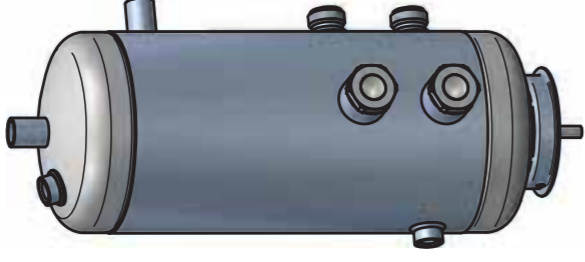
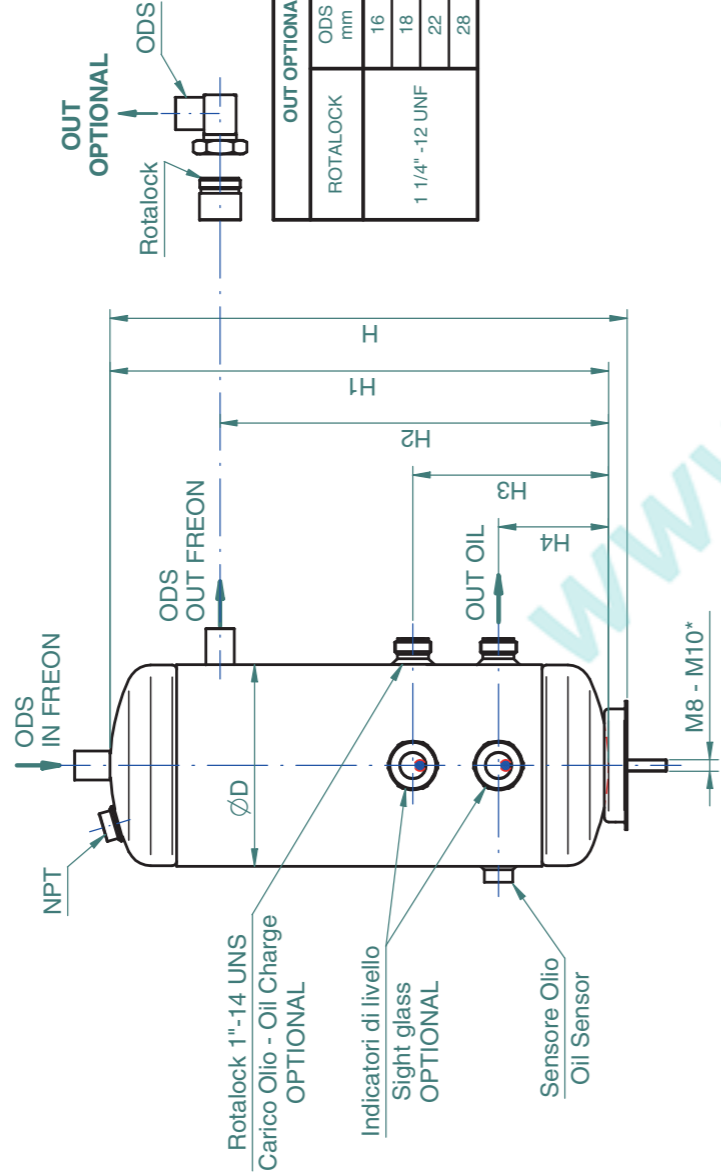

OUT OPTIONAL		
ROTALOCK	ODS mm inch.	
1 1/4" -12 UNF	16	5/8"
	18	3/4"
	22	7/8"
	28	1 1/8"

MASSIMA PRESSIONE DI LAVORO Maximum working pressure	PS 130 bar
TEMPERATURA AMMISSIBILE Permissible temperature	TS -40/+120°C
PRESSIONE DI COLLAUDO Testing pressure	PT 186 bar
COLORE Colour	BLACK RAL 9005
RESISTENZA ALLA CORROSIONE IN NEBBIA SALINA DI 250 ORE SECONDO NORMA ASTM-B117. RESISTENZA FINO A 1000 ORE SU RICHIESTA Corrosion resistance on salt spray at 250 hours according standard ASTM-B117. 1000 hours resistance on customer request.	

* CON PIASTRA PER Ø219
With plate for Ø219

**FILTRI DISIDRATORI A SETACCIO MOLECOLARE E ATTACCHI SAE -
Molecular sieve filter drier with SAE connections**

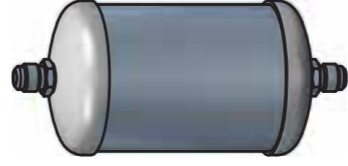
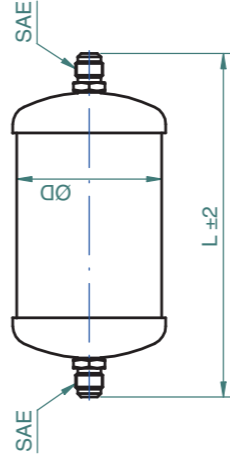

- According to ARI STANDARD 710-86
Tc: condensing temperature +30 °C
Te: evaporating temperature -15 °C
Δp: charge with a drop pressure of 0,07 bar

- Drying capacity is based on following moisture contents in the refrigerants before and after drying:
-R22 from 1050 PPM W to 60 PPM W
-R134a from 1050 PPM W to 75 PPM W
-R404A / R407C / R507 from 1020 PPM W to 30 PPM W
-R410A from 1050 PPM W to 60 PPM W

CODE	SAE	ØD mm	L ±2 mm	VOL. cm³	PESO gr.	WATER ABSORPTION CAPACITY 25°C gr				WATER ABSORPTION CAPACITY 50°C gr				FLOW CAPACITY (kW)				
						R134a	R22	R404A	R407C	R507	R134a	R22	R404A	R407C	R507	R134a	R504A - R507	R22 -R407C -R410A
DLU05214FL	1/4"	48	83	83	260	4,3	4,2	4,6	2,8	4,1	3,6	3,4	4,0	2,8	3,2	6	4	7,5
DLU05338FL	3/8"	48	83	83	290	4,3	4,2	4,6	2,8	4,1	3,6	3,4	4,0	2,8	3,2	15	10	7,5
DLU08214FL	1/4"	48	125	125	310	7,5	7,4	8,1	4,9	7,1	6,3	6,0	7,0	4,9	5,6	8,5	6	10
DLU08338FL	3/8"	63	210	210	490	10,6	10,5	11,3	6,9	10,1	9,0	8,6	10,0	7,0	8,0	21	15	23
DLU08412FL	1/2"	63	230	230	520	13,6	13,5	15,0	9,0	13,3	12,0	11,5	13,5	9,2	10,6	29	22	32
DLU16338FL	3/8"	63	265	265	580	18,0	17,8	19,6	11,8	17,3	15,3	14,6	17,0	11,9	13,6	25	18	27
DLU16412FL	1/2"	63	265	265	590	18,0	17,8	19,6	11,8	17,3	15,3	14,6	17,0	11,9	13,6	34	25	37
DLU16558FL	5/8"	79	450	450	790	29,6	29,3	32,2	19,3	28,3	25,2	24,1	28,0	19,6	22,4	47	33	52
DLU30038FL	3/8"	79	750	750	1100	60,0	59,2	65,1	39,0	57,3	51,5	49,2	57,3	40,1	45,7	26	20	30
DLU30412FL	1/2"	79	750	750	1110	60,0	59,2	65,1	39,0	57,3	51,5	49,2	57,3	40,1	45,7	37	27	41
DLU30558FL	5/8"	79	750	750	1120	60,0	59,2	65,1	39,0	57,3	51,5	49,2	57,3	40,1	45,7	53	39	59
DLU30634FL	3/4"	79	750	750	1200	60,0	59,2	65,1	39,0	57,3	51,5	49,2	57,3	40,1	45,7	65	47	70

FILTRI DISIDRATORI A SETACCIO MOLECOLARE E ATTACCHI ODS - Molecular sieve filter drier with ODS connections

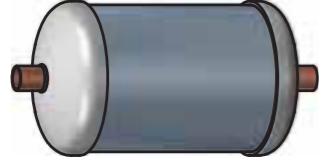
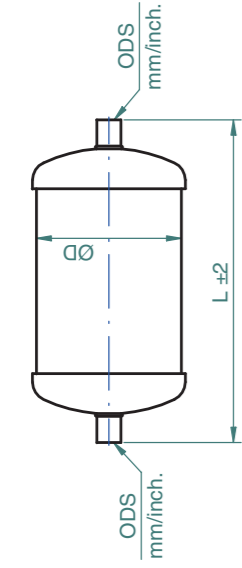

- According to ARI STANDARD 710-86
Tc: condensing temperature +30 °C
Te: evaporating temperature -15 °C
Δp: charge with a drop pressure of 0,07 bar

- Drying capacity is based on following moisture contents in the refrigerants before and after drying:
-R22 from 1050 PPM W to 60 PPM W
-R134a from 1050 PPM W to 75 PPM W
-R404A / R407C / R507 from 1020 PPM W to 30 PPM W
-R410A from 1050 PPM W to 60 PPM W

CODE	ODS		ØD mm	L ±2 mm	VOL. cm³	PESO gr.	WATER ABSORPTION CAPACITY 25°C gr				WATER ABSORPTION CAPACITY 50°C gr				FLOW CAPACITY (kW)			
	mm	inch.					R134a	R22	R404A	R407C	R507	R134a	R22	R404A	R407C	R507	R134a	R504A - R507
DLU0520600	6	1/4"	48	102	83	260	4,3	4,2	4,6	2,8	4,1	3,6	3,4	4,0	3,2	6	4	7,5
DLU0520014		3/8"	48	102	83	260	4,3	4,2	4,6	2,8	4,1	3,6	3,4	4,0	2,8	6	4	7,5
DLU0530038	10		48	112	83	290	4,3	4,2	4,6	2,8	4,1	3,6	3,4	4,0	2,8	15	10	16
DLU0531000	6		48	112	83	290	4,3	4,2	4,6	2,8	4,1	3,6	3,4	4,0	2,8	15	10	16
DLU0820600		1/4"	48	132	125	310	7,5	7,4	8,1	4,9	7,1	6,3	6,0	7,0	4,9	8,5	6	10
DLU0820014		3/8"	48	132	125	310	7,5	7,4	8,1	4,9	7,1	6,3	6,0	7,0	4,9	8,5	6	10
DLU0830038	10		63	136	210	490	10,6	10,5	11,3	6,9	10,1	9,0	8,6	10,0	8,0	21	15	23
DLU0831000	6		63	136	210	490	10,6	10,5	11,3	6,9	10,1	9,0	8,6	10,0	7,0	21	15	23
DLU0841200	12		63	143	230	520	13,6	13,5	15,0	9,0	13,3	12,0	11,5	13,5	9,2	29	22	32
DLU0840012		1/2"	63	143	230	520	13,6	13,5	15,0	9,0	13,3	12,0	11,5	13,5	9,2	29	22	32
DLU1630038	10		63	156	265	580	18,0	17,8	19,6	11,8	17,3	15,3	14,6	17,0	11,9	25	18	27
DLU1631000	6		63	156	265	580	18,0	17,8	19,6	11,8	17,3	15,3	14,6	17,0	11,9	25	18	27
DLU1641200	12		63	156	265	590	18,0	17,8	19,6	11,8	17,3	15,3	14,6	17,0	11,9	34	25	37
DLU1640012		1/2"	63	156	265	590	18,0	17,8	19,6	11,8	17,3	15,3	14,6	17,0	11,9	34	25	37
DLU1651658	16		79	164	450	790	29,6	29,3	32,2	19,3	28,3	25,2	24,1	28,0	19,6	47	33	52
DLU2030038		3/8"	79	232	750	1100	60,0	59,2	65,1	39,0	57,3	51,5	49,2	57,3	40,1	26	20	30
DLU3031000	10		79	232	750	1100	60,0	59,2	65,1	39,0	57,3	51,5	49,2	57,3	40,1	26	20	30
DLU3041200	12		79	232	750	1110	60,0	59,2	65,1	39,0	57,3	51,5	49,2	57,3	40,1	27	20	30
DLU3040012		1/2"	79	232	750	1110	60,0	59,2	65,1	39,0	57,3	51,5	49,2	57,3	40,1	27	20	30
DLU3051658	16		79	240	750	1120	60,0	59,2	65,1	39,0	57,3	51,5	49,2	57,3	40,1	27	20	30
DLU3061934	19		79	240	750	1200	60,0	59,2	65,1	39,0	57,3	51,5	49,2	57,3	40,1	27	20	30

FILTRI DISIDRATORI A CARTUCCIA RICAMBIABILE - Desiccant replaceable cartridge filters

TIPO	ODS		Ø1	Ø2	A	B	C	D	N° CARTUCCE Number of cartridge	CAPACITA' INDICATIVA Indicative flow capacity (kW)			CAPACITA' ASSORBIMENTO Water capacity (g H ₂ O at 25°C)					
	mm	inch.								R134a	R407C R410A	R404A R507	R134a	R407C R410A	R404A R507			
DLFR16058/1	16	5/8"	114	154	131	228	90	210	1	45	45	25						
DLFR22078/1	22	7/8"	114	154	140	230	95	210	1	50	58	32						
DLFR28118/1	28	1 1/8"	114	154	146	236	95	210	1	70	72	40						
DLFR35138/1	35	1 3/8"	114	154	155	245	100	210	1	80	80	55						
DLFR42158/1	42	1 5/8"	114	154	164	254	115	210	1	90	95	70						
DLFR54218/1	54	2 1/8"	114	154	170	265	115	210	1	120	120	95						
DLFR22078/2	22	7/8"	114	154	285	375	95	350	2	75	90	50						
DLFR28118/2	28	1 1/8"	114	154	291	382	95	350	2	95	120	65						
DLFR35138/2	35	1 3/8"	114	154	300	399	100	350	2	115	145	80						
DLFR42158/2	42	1 5/8"	114	154	309	399	105	350	2	125	160	86						
DLFR54218/2	54	2 1/8"	114	154	320	410	105	350	2	130	165	95						
DLFR22078/3	22	7/8"	114	154	425	515	100	490	3	110	120	70						
DLFR28118/3	28	1 1/8"	114	154	438	521	100	490	3	130	140	95						
DLFR35138/3	35	1 3/8"	114	154	440	530	100	490	3	150	165	105						
DLFR42158/3	42	1 5/8"	114	154	449	539	105	490	3	170	210	115						
DLFR54218/3	54	2 1/8"	114	154	460	550	105	490	3	200	235	135						
DLFR28118/4	28	1 1/8"	114	154	571	661	100	630	4	270	280	155						
DLFR35138/4	35	1 3/8"	114	154	580	670	100	630	4	320	320	205						
DLFR42158/4	42	1 5/8"	114	154	589	679	105	630	4	350	370	260						
DLFR54218/4	54	2 1/8"	114	154	600	690	105	630	4	400	390	390						

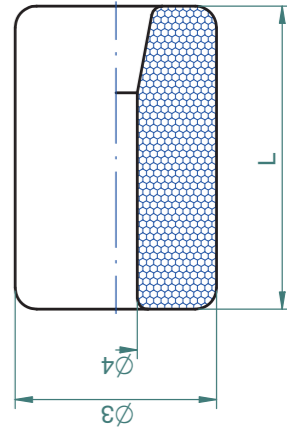
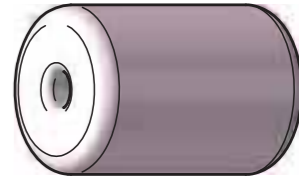
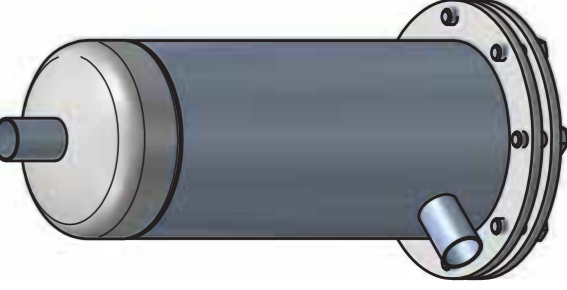
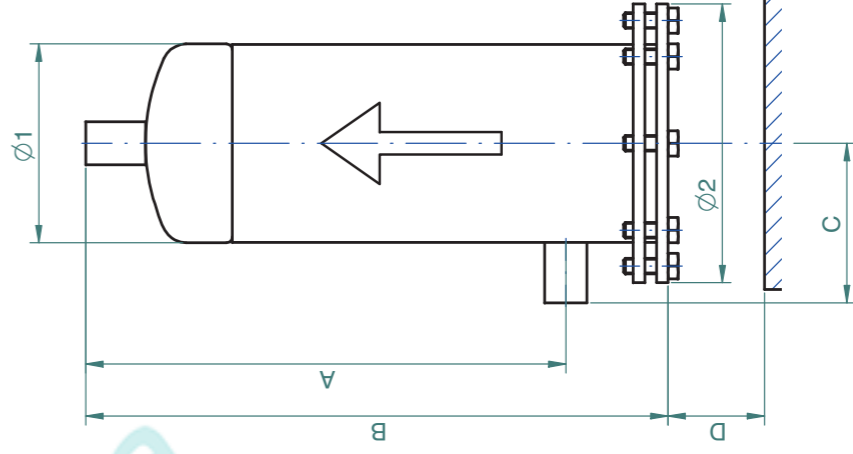

CARTUCCIA RICAMBIABILE - Replaceable cartridge

L	Ø3	Ø4	TIPO
mm	mm	mm	Type
140	94	44	100% MOLECULAR SIEVES
140	94	44	80% M.S. + 20% ACTIVATED ALUMINA
			SCA
			SCB

MASSIMA PRESSIONE DI LAVORO Maximum working pressure	PS 35 bar / 44 bar (CO ₂)
TEMPERATURA AMMISSIBILE Permissible temperature	TS -40/+120°C
PRESSIONE DI COLLAUDO Testing pressure	PT = PS x 1,43 (bar)
COLORE Colour	BLACK RAL 9005
RESISTENZA ALLA CORROSIONE IN NEBBIA SALINA DI 250 ORE SECONDO NORMA ASTM-B117. RESISTENZA FINO A 1000 ORE SU RICHIESTA. Corrosion resistance on salt spray at 250 hours according standard ASTM-B117. 1000 hours resistance on customer request.	

FILTRI DISIDRATORI CON RISERVA DI LIQUIDO
Desiccant Filters with liquid reserve

ODS		ØD	H	Volume
mm	inch.	mm	mm	cm³
6				
	1/4"			
	3/8"	77	148	470
10				
12				
	1/2"			
	5/8"			
16				
	3/8"			
10				
12		77	193	725
	1/2"			
	5/8"			
16				
18				
	3/4"			
12				
	1/2"			
	5/8"			
16		77	213	815
18				
	3/4"			
22				
	7/8"			

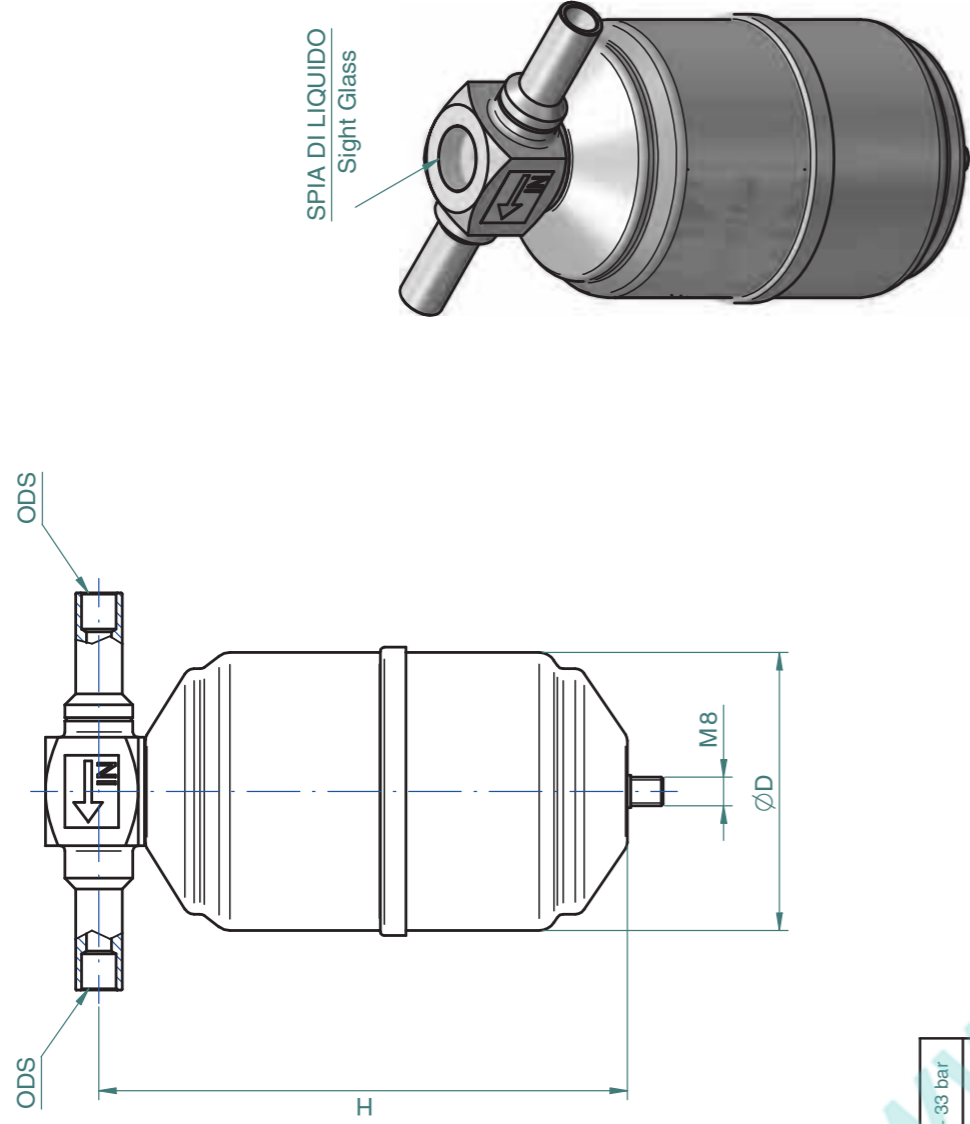

- SOLID CORE 100% MOLECULAR SIEVES

MASSIMA PRESSIONE DI LAVORO Maximum working pressure	PS 45 bar	PS 20 ± 33 bar
TEMPERATURA AMMISSIBILE Permissible temperature	TS -10/+120°C	TS -40/+120°C
PRESSIONE DI COLLAUDO Testing pressure	PT = PS x 1,43 (bar)	
COLORE Colour	BLACK RAL 9005	
RESISTENZA ALLA CORROSIONE IN NEBBIA SALINA DI 250 ORE SECONDO NORMA ASTM-B117. RESISTENZA FINO A 1000 ORE SU RICHIESTA. Corrosion resistance on salt spray at 250 hours according standard ASTM-B117. 1000 hours resistance on customer request.		

FILTRI MECCANICI A CARTUCCIA FILTRANTE RICAMBIABILE -
Mechanical filter with replaceable cartridge

TIPO	Ø1		Ø2		A	B	C	D
Type	mm	inch.	mm	mm	mm	mm	mm	mm
DLFMR22078	22	7/8"	114	154	140	230	95	185
DLFMR28118	28	1 1/8"	114	154	146	236	95	185
DLFMR35138	35	1 3/8"	114	154	155	245	100	185
DLFMR42158	42	1 5/8"	114	154	164	254	115	185
DLFMR54218	54	2 1/8"	114	154	170	265	115	185

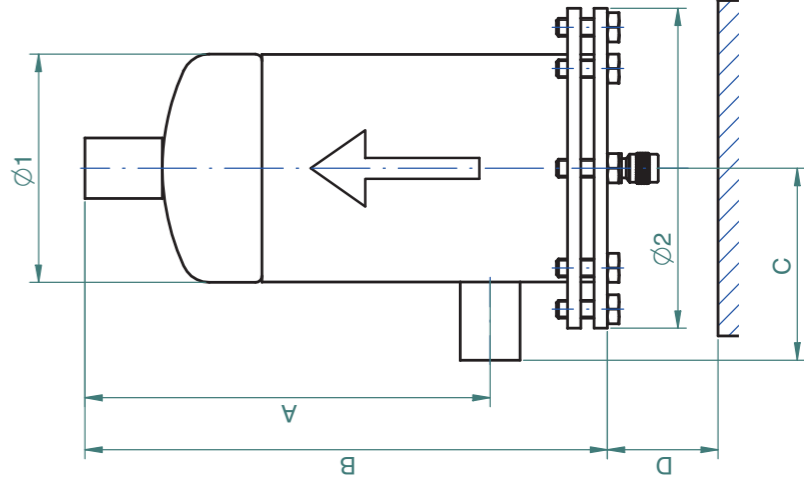
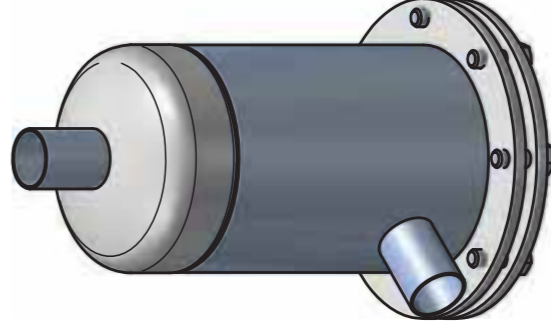

MASSIMA PRESSIONE DI LAVORO Maximum working pressure	PS 35 bar / 44 bar (CO ₂)
TEMPERATURA AMMISSIBILE Permissible temperature	TS -40/+120°C
PRESSIONE DI COLLAUDO Testing pressure	PT = PS x 1,43 (bar)
COLORE Colour	BLACK RAL 9005
RESISTENZA ALLA CORROSIONE IN NEBBIA SALINA DI 250 ORE SECONDO NORMA ASTM-B117. RESISTENZA FINO A 1000 ORE SU RICHIESTA. Corrosion resistance on salt spray at 250 hours according standard ASTM-B117. 1000 hours resistance on customer request.	

FILTRI MECCANICI A RETE NON RICARICABILI (POSSONO ESSERE QUALIFICATI RICEVITORI DI LIQUIDO) - Grid mechanical filter non rechargeable (can be qualified like liquid receivers)

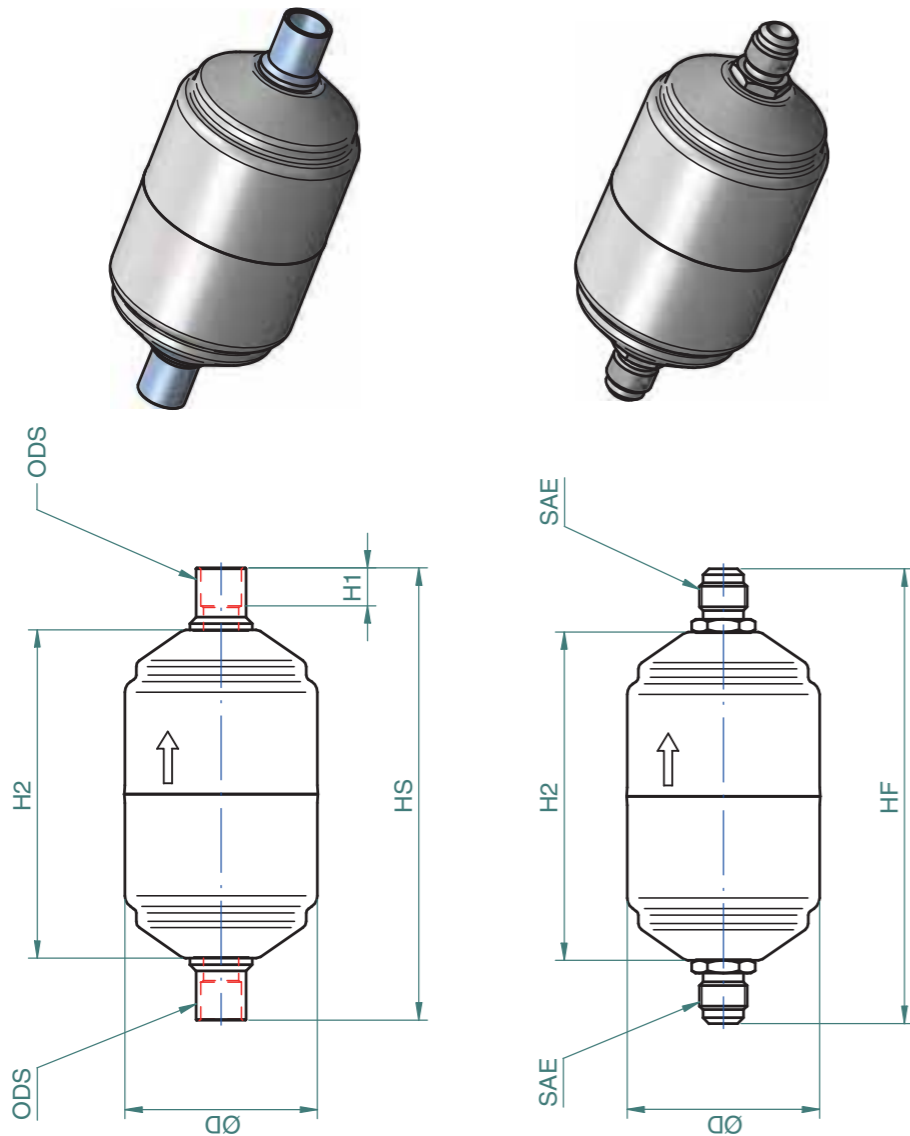

MASSIMA PRESSIONE DI LAVORO Maximum working pressure	PS 45 bar	PS 20 ± 33 bar
TEMPERATURA AMMISSIBILE Permissible temperature	TS -10/+120°C	TS -40/+120°C
PRESSIONE DI COLLAUDO Testing pressure	PT = PS x 1,43 (bar)	
COLORE Colour	BLACK RAL 9005	
RESISTENZA ALLA CORROSIONE IN NEBBIA SALINA DI 250 ORE SECONDO NORMA ASTM-B117. RESISTENZA FINO A 1000 ORE SU RICHIESTA. Corrosion resistance on salt spray at 250 hours according standard ASTM-B117. 1000 hours resistance on customer request.		

TIPO Type	SAE	ODS		ØD	HF (SAE) mm	HS (ODS) mm	H1	H2	Vol. cm³
		mm	inch.						
DLFM053	3/8"	10	3/8"	60	132	125	10	80	185
DLFM083	3/8"	10	3/8"	60	146	141	10	95	230
DLFM084	1/2"	12	1/2"	60	146	148	12	95	230
DLFM164	1/2"	12	1/2"	77	186	188	12	135	470
DLFM165	5/8"	16	5/8"	77	194	196	14	135	470
DLFM304	1/2"	12	1/2"	77	232	233	12	180	725
DLFM305	5/8"	16	5/8"	77	242	241	14	180	725
DLFM307	/	22	7/8"	77	/	249	16	180	725
DLFM415	/	16	5/8"	77	/	261	14	200	815
DLFM417	/	22	7/8"	77	/	269	16	200	815

INFORMAZIONI GENERALI RELATIVE A RUBINETTI TIPO ROTALOCK - RUBINETTI FLANGIATI - RUBINETTI A SALDARE - RUBINETTI VERTICALI - PER FLUIDI REFRIGERANTI DEL GRUPPO 1 E 2 DELLA PED

General information relatives to Rotalock Valves - Flanged Valves - Soldering Valves - Vertical Valves - For Refrigerant Fluid Group 1 and 2 PED

(I) La Dena Line è in grado di fornire rubinetti nel campo della refrigerazione e condizionamento sia ad avvitare con attacchi Rotalock da 3/4" a 2 1/4" sia a saldare su ricevitori di liquido o compressori ermetici. Tutti i rubinetti DENA LINE sono dotati di una speciale guarnizione in grado di resistere al calore sino a 1000°C. Dopo la brasatura in forno, tutti i rubinetti e raccordi sono controllati per verificare l'assenza di difetti; i rubinetti e raccordi finiti sono quindi collaudati a 40 Bar per la perfetta tenuta a pressione. Le eventuali prese di pressione o BY-PASS sono fornite con tappi in acciaio stampato. Tutti i rubinetti DENA LINE sono protetti contro l'ossidazione e possono essere forniti con un trattamento superficiale di nichelatura, stagnatura o ramatura. La DENA LINE è in grado di studiare rubinetti che rispondono alle specifiche esigenze dei propri clienti. Le varie filettature dei raccordi dei rubinetti tengono conto delle norme UNF e SAE. Nella seguente tabella vengono indicate le relative corrispondenze.

(GB) Dena Line is able to supply valves for the air conditioning and refrigeration areas, either to be screwed with Rotalock connections from 3/4" to 2 1/4" or to be soldered on to liquid receivers or hermetic compressors. All the valves are equipped with a special gasket meant to resist to a heat of up to 1000°C. Following furnace brazing, each valve is inspected for possible defects. Once completed, the valves are then tested at 40 Bar pressure for a perfect pressure seal. The optional gage ports or BY-PASS are supplied with pressed steel caps. All DENA LINE valves are protected against oxydation and can be delivered with surface treatment as nickel, copper, and tinned. If needed, DENA LINE can also design a completely new valve meeting all customers' specific requirements. The various thread of the valves fittings are in accordance with UNF and SAE standards. The tables hereafter shows the correspondences.

UNF	SAE	N° Filetti per pollice	Ø esterno filettatura mm
7/16" UNF	1/4" SAE	20	11,113
9/16" UNF	-	18	14,287
5/8" UNF	3/8" SAE	18	15,875
11/16" UN	-	16	17,462
3/4" UNF	1/2" SAE	16	19,050
13/16" UN	-	16	20,637
7/8" UNF	5/8" SAE	14	22,225
1" UNS	-	14	25,400
1 1/16" UNS	3/4" SAE	14	26,988
1 1/4" UNF	7/8" SAE	12	31,750
1 1/2" UN	1 1/8" SAE	16	38,100
1 3/4" UN	-	12	44,450
2 1/4" UN	-	12	57,150

(I) Si ricorda che il termine "filettatura SAE" non si intende la caratteristica della filettatura ma unicamente il diametro esterno del tubo impiegato che va collegato all' attacco mediante un bocchettone con opportuna svasatura. Il termine UNF definisce invece le caratteristiche della filettatura ed il diametro esterno della filettatura stessa. Con la sigla ODS si intende un attacco a saldare il cui diametro in pollici o in millimetri si riferisce al diametro esterno del tubo da inserire nell' attacco stesso (vedi esempio).

(GB) We wish to point out that "SAE threadings" doesn't stand for thread specifications but only for the external diameter of the tube used for the connection with the joint, by means of a flared nut. On the opposite, the term "UNF" describes the thread specifications and its outer diameter. The ODS abbreviation stands for a soldering connection whose diameter in inches or millimeters refers to the external diameter of the tube to be plugged into the connection (see example).

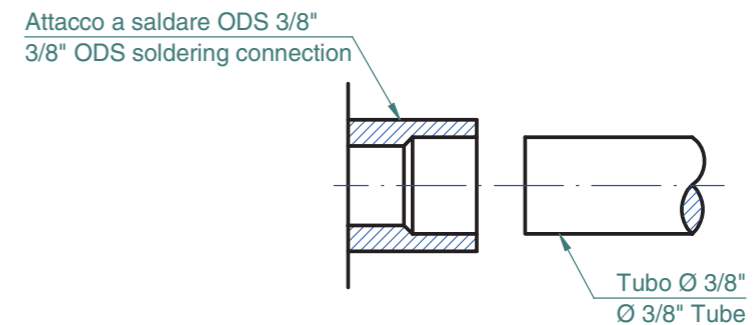

RUBINETTI ROTALOCK CON ATTACCO IN USCITA FLARE (SAE) - Rotalock Valves with Flare Connection (SAE)

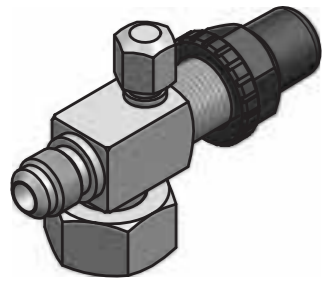
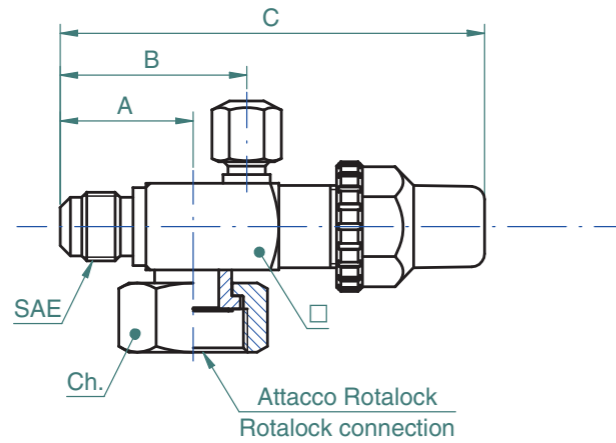

Presca Pressione tipo Cx
Cx Gage port

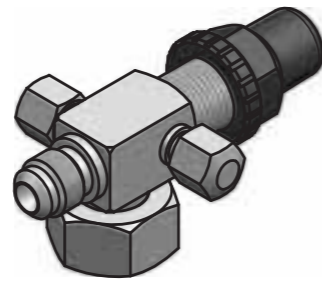

Presca Pressione tipo Sx e Dx in By-Pass
SX Gage port and Dx in By-Pass

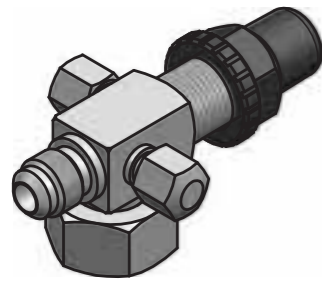

Presca Pressione tipo Dx e Sx in By-Pass
Dx Gage port and Sx in By-Pass



Raccordo Schrader 1/4" SAE
1/4" SAE Schrader connection

□	Attacco Rotalock	Uscita SAE	Presca pressione	By-Pass	A	B	C	Ch.
mm			Cx-Sx-Dx	Cx-Sx-Dx	mm	mm	mm	mm
□20	3/4" -16 UNF	1/4" SAE	Cx		25,5	38	90	24
			Sx	Dx	25,5	38	90	24
			Dx	Sx	25,5	38	90	24
		3/8" SAE	Cx		30,5	43	95	24
			Sx	Dx	30,5	43	95	24
			Dx	Sx	30,5	43	95	24
	1" -14 UNS	1/2" SAE	Cx		33,5	46	98	24
			Sx	Dx	33,5	46	98	24
		1/4" SAE	Cx		25,5	38	90	30
			Sx	Dx	25,5	38	90	30
			Dx	Sx	25,5	38	90	30
			3/8" SAE	Cx		30,5	43	95
Sx	Dx	30,5		43	95	30		
Dx	Sx	30,5		43	95	30		

□	Attacco Rotalock	Uscita SAE	Presca pressione	By-Pass	A	B	C	Ch.
mm			Cx-Sx-Dx	Cx-Sx-Dx	mm	mm	mm	mm
□20	1" -14 UNS	1/2" SAE	Cx		33,5	46	98	30
			Sx	Dx	33,5	46	98	30
			Dx	Sx	33,5	46	98	30
		5/8" SAE	Cx		36,5	49	101	30
			Sx	Dx	36,5	49	101	30
			Dx	Sx	36,5	49	101	30
□22	1" -14 UNS	5/8" SAE	Cx		43	57	124	30
			Sx	Dx	43	57	124	30
			Dx	Sx	43	57	124	30
		3/4" SAE	Cx		47	61	128	30
			Sx	Dx	47	61	128	30
			Dx	Sx	47	61	128	30
□22	1 1/4" - 12 UNF	5/8" SAE	Cx		43	57	124	36
			Sx	Dx	43	57	124	36
			Dx	Sx	43	57	124	36
		3/4" SAE	Cx		47	61	128	36
			Sx	Dx	47	61	128	36
			Dx	Sx	47	61	128	36
□30	1 1/4" - 12 UNF	5/8" SAE	Cx		45	62	134	36
			Sx	Dx	45	62	134	36
			Dx	Sx	45	62	134	36
		3/4" SAE	Cx		45	62	134	36
			Sx	Dx	45	62	134	36
			Dx	Sx	45	62	134	36

MASSIMA PRESSIONE DI LAVORO Maximum working pressure	PS 50 bar	PS 37 bar
TEMPERATURA AMMISSIBILE Permissible temperature	TS -10/+150 °C	TS -40/+150 °C
PRESSIONE DI COLLAUDO Testing pressure	PT 71,5 bar	
FLUIDO REFRIGERANTE Refrigerant	GROUP 2 PED	
CATEGORIA PED Category PED	ARTICLE 3.3	
TRATTAMENTO SUPERFICIALE: RAMATURA, NICHELATURA O STAGNATURA. Surface treatment: copper, nickel or tin plated.		

**RUBINETTI ROTALOCK CON ATTACCO IN USCITA A SALDARE -
Rotalock Valves with solder connection.**

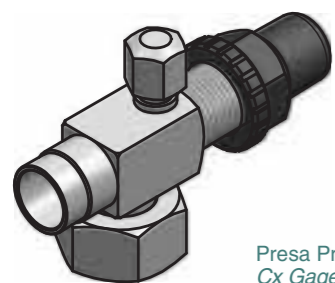
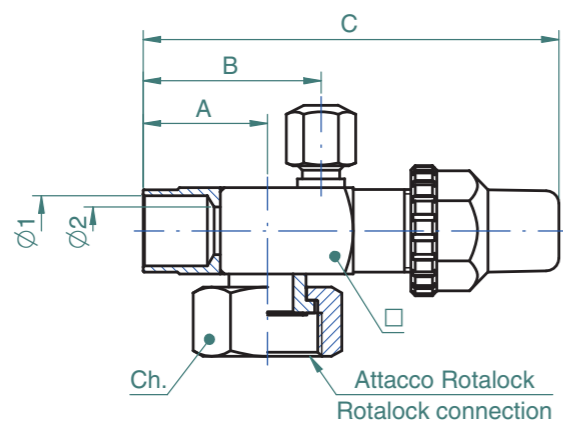

Presca Pressione tipo Cx
Cx Gage port

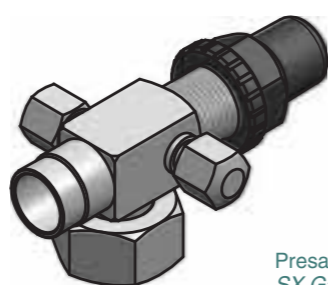

Presca Pressione tipo Sx e Dx in By-Pass
SX Gage port and Dx in By-Pass

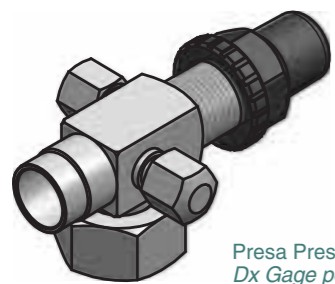

Presca Pressione tipo Dx e Sx in By-Pass
Dx Gage port and Sx in By-Pass



Raccordo Schrader 1/4" SAE
1/4" SAE Schrader connection

□	Attacco Rotalock	Uscita ODS		Presca pressione	By-Pass	Ø1	Ø2	A	B	C	Ch.
		mm	inch.								
□20	3/4" -16 UNF	6	1/4"	Cx		6,2	5	26	38,5	94	24
				Sx	Dx	6,2	5	26	38,5	94	24
				Dx	Sx	6,2	5	26	38,5	94	24
				Cx		6,45	5,5	26	38,5	94	24
				Sx	Dx	6,45	5,5	26	38,5	94	24
				Dx	Sx	6,45	5,5	26	38,5	94	24
		8	1/4"	Cx		8,2	7	26	38,5	94	24
				Sx	Dx	8,2	7	26	38,5	94	24
				Dx	Sx	8,2	7	26	38,5	94	24
				Cx		9,7	8,5	26	38,5	94	24
				Sx	Dx	9,7	8,5	26	38,5	94	24
				Dx	Sx	9,7	8,5	26	38,5	94	24
		10	3/8"	Cx		10,2	9	26	38,5	94	24
				Sx	Dx	10,2	9	26	38,5	94	24
				Dx	Sx	10,2	9	26	38,5	94	24

□	Attacco Rotalock	Uscita ODS		Presca pressione	By-Pass	Ø1	Ø2	A	B	C	Ch.		
		mm	inch.									Cx-Sx-Dx	Cx-Sx-Dx
□20	1" -14 UNS	10	3/8"	Cx		9,7	8,5	26	38,5	94	30		
				Sx	Dx	9,7	8,5	26	38,5	94	30		
				Dx	Sx	9,7	8,5	26	38,5	94	30		
				Cx		10,2	9	26	38,5	94	30		
				Sx	Dx	10,2	9	26	38,5	94	30		
				Dx	Sx	10,2	9	26	38,5	94	30		
				12	3/8"	Cx		12,25	11	29	41,5	97	30
						Sx	Dx	12,25	11	29	41,5	97	30
						Dx	Sx	12,25	11	29	41,5	97	30
		16	1/2"	Cx		12,95	11	29	41,5	97	30		
				Sx	Dx	12,95	11	29	41,5	97	30		
				Dx	Sx	12,95	11	29	41,5	97	30		
				5/8"	Cx		16,2	11	29	41,5	97	30	
					Sx	Dx	16,2	11	29	41,5	97	30	
					Dx	Sx	16,2	11	29	41,5	97	30	
		□22	1 1/4" -12 UNF	16	5/8"	Cx		16,2	13,5	37	51	120	36
						Sx	Dx	16,2	13,5	37	51	120	36
						Dx	Sx	16,2	13,5	37	51	120	36
18	3/4"			Cx		18,25	13,5	37	51	120	36		
				Sx	Dx	18,25	13,5	37	51	120	36		
				Dx	Sx	18,25	13,5	37	51	120	36		
				Cx		19,3	13,5	37	51	120	36		
				Sx	Dx	19,3	13,5	37	51	120	36		
				Dx	Sx	19,3	13,5	37	51	120	36		
□30	1 1/4" -12 UNF			18	3/4"	Cx		18,25	18	40	57	129	36
						Sx	Dx	18,25	18	40	57	129	36
						Dx	Sx	18,25	18	40	57	129	36
		22	7/8"	Cx		19,3	18	40	57	129	36		
				Sx	Dx	19,3	18	40	57	129	36		
				Dx	Sx	19,3	18	40	57	129	36		
				Cx		22,25	18	40	57	129	36		
				Sx	Dx	22,25	18	40	57	129	36		
				Dx	Sx	22,25	18	40	57	129	36		
		28	1 1/8"	Cx		22,45	18	40	57	129	36		
				Sx	Dx	22,45	18	40	57	129	36		
				Dx	Sx	22,45	18	40	57	129	36		
				Cx		28,3	18	53	70	142	36		
				Sx	Dx	28,3	18	53	70	142	36		
				Dx	Sx	28,3	18	53	70	142	36		
				Cx		28,85	18	53	70	142	36		
				Sx	Dx	28,85	18	53	70	142	36		
				Dx	Sx	28,85	18	53	70	142	36		
□30	1 3/4" -12 UN	22	7/8"	Cx		22,25	18	40	57	129	50		
				Sx	Dx	22,25	18	40	57	129	50		
				Dx	Sx	22,25	18	40	57	129	50		
		28	1 1/8"	Cx		22,45	18	40	57	129	50		
				Sx	Dx	22,45	18	40	57	129	50		
				Dx	Sx	22,45	18	40	57	129	50		
				Cx		28,3	18	53	70	142	50		
				Sx	Dx	28,3	18	53	70	142	50		
				Dx	Sx	28,3	18	53	70	142	50		
		Cx		28,85	18	53	70	142	50				
		Sx	Dx	28,85	18	53	70	142	50				
		Dx	Sx	28,85	18	53	70	142	50				

□	Attacco Rotalock	Uscita ODS		Pres. pressione	By-Pass	Ø1	Ø2	A	B	C	Ch.		
		mm	inch.									Cx-Sx-Dx	Cx-Sx-Dx
□35	1 3/4" -12 UN	28		Cx		28,3	26,5	56	79,5	182	50		
				Sx	Dx	28,3	26,5	56	79,5	182	50		
				Dx	Sx	28,3	26,5	56	79,5	182	50		
				Cx		28,85	26,5	56	79,5	182	50		
				Sx	Dx	28,85	26,5	56	79,5	182	50		
				Dx	Sx	28,85	26,5	56	79,5	182	50		
		35	1 3/8"	35	1 3/8"	Cx		35,3	26,5	58	81,5	184	50
						Sx	Dx	35,3	26,5	58	81,5	184	50
						Dx	Sx	35,3	26,5	58	81,5	184	50
						Cx		41,6	26,5	61	84,5	187	50
						Sx	Dx	41,6	26,5	61	84,5	187	50
						Dx	Sx	41,6	26,5	61	84,5	187	50
42		42		Cx		42,35	26,5	61	84,5	187	50		
				Sx	Dx	42,35	26,5	61	84,5	187	50		
				Dx	Sx	42,35	26,5	61	84,5	187	50		
				Cx		54,4	34	74	101	209	65		
				Sx	Dx	54,4	34	74	101	209	65		
				Dx	Sx	54,4	34	74	101	209	65		

MASSIMA PRESSIONE DI LAVORO Maximum working pressure	PS 50 bar	PS 37 bar
TEMPERATURA AMMISSIBILE Permissible temperature	TS -10/+150 °C	TS -40/+150 °C
PRESSIONE DI COLLAUDO Testing pressure	PT 71,5 bar	
FLUIDO REFRIGERANTE Refrigerant	GROUP 2 PED	
CATEGORIA PED Category PED	ARTICLE 3.3	
TRATTAMENTO SUPERFICIALE: RAMATURA, NICHELATURA O STAGNATURA. Surface treatment: copper, nickel or tin plated.		

RUBINETTI ROTALOCK CON ODS IN USCITA IN RAME -
Rotalock Valves with copper outlet ODS

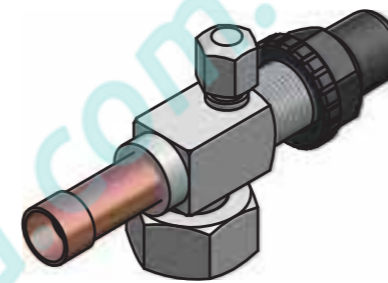
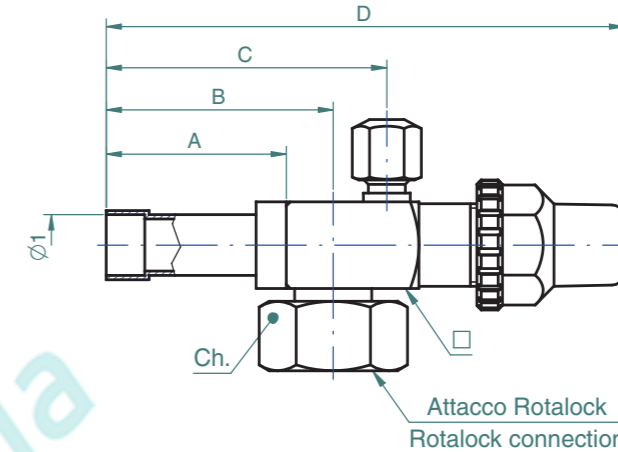

Pres. Pressione tipo Cx
Cx Gage port

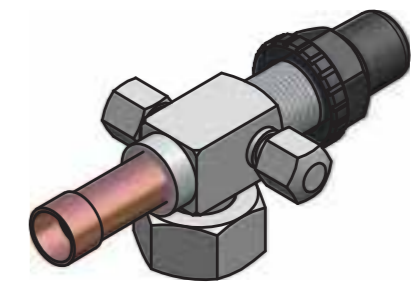

Pres. Pressione tipo Sx e Dx in By-Pass
SX Gage port and Dx in By-Pass

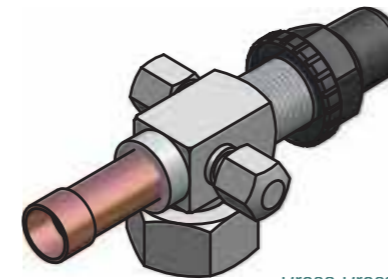

Pres. Pressione tipo Dx e Sx in By-Pass
Dx Gage port and Sx in By-Pass



Raccordo Schrader 1/4" SAE
1/4" SAE Schrader connection

□	Attacco Rotalock	Uscita ODS		Pres. pressione	By-Pass	Ø1	A	B	C	D	Ch.		
		mm	inch.									Cx-Sx-Dx	Cx-Sx-Dx
□20	3/4" -16 UNF	6	1/4"	Cx		6,2	35	46	58,5	114	24		
				Sx	Dx	6,2	35	46	58,5	114	24		
				Dx	Sx	6,2	35	46	58,5	114	24		
				Cx		6,5	35	46	58,5	114	24		
				Sx	Dx	6,5	35	46	58,5	114	24		
				Dx	Sx	6,5	35	46	58,5	114	24		
		8	3/8"	8	3/8"	Cx		8,2	35	46	58,5	114	24
						Sx	Dx	8,2	35	46	58,5	114	24
						Dx	Sx	8,2	35	46	58,5	114	24
						Cx		9,7	35	46	58,5	114	24
						Sx	Dx	9,7	35	46	58,5	114	24
						Dx	Sx	9,7	35	46	58,5	114	24
10		10		Cx		10,2	35	46	58,5	114	24		
				Sx	Dx	10,2	35	46	58,5	114	24		
				Dx	Sx	10,2	35	46	58,5	114	24		

□	Attacco Rotalock	Uscita ODS		Pres. pressione	By-Pass	Ø1	A	B	C	D	Ch.			
		mm	inch.									Cx-Sx-Dx	Cx-Sx-Dx	
□20	1" -14 UNS	10	3/8"	Cx		9,7	35	46	58,5	114	30			
				Sx	Dx	9,7	35	46	58,5	114	30			
				Dx	Sx	9,7	35	46	58,5	114	30			
			12	Cx		10,2	35	46	58,5	114	30			
				Sx	Dx	10,2	35	46	58,5	114	30			
				Dx	Sx	10,2	35	46	58,5	114	30			
		16	1/2"	Cx		12,2	35	46	58,5	114	30			
				Sx	Dx	12,2	35	46	58,5	114	30			
				Dx	Sx	12,2	35	46	58,5	114	30			
			5/8"	Cx		12,8	35	46	58,5	114	30			
				Sx	Dx	12,8	35	46	58,5	114	30			
				Dx	Sx	12,8	35	46	58,5	114	30			
		□22	1 1/4" -12 UNF	16	5/8"	Cx		16,2	35	50	64	133	36	
						Sx	Dx	16,2	35	50	64	133	36	
						Dx	Sx	16,2	35	50	64	133	36	
					18	Cx		18,2	52	67	81	150	36	
						Sx	Dx	18,2	52	67	81	150	36	
						Dx	Sx	18,2	52	67	81	150	36	
3/4"	Cx				19,2	52	67	81	150	36				
	Sx			Dx	19,2	52	67	81	150	36				
	Dx			Sx	19,2	52	67	81	150	36				
	□30			1 1/4" -12 UNF	18	3/4"	Cx		18,2	52	69	86	158	36
							Sx	Dx	18,2	52	69	86	158	36
							Dx	Sx	18,2	52	69	86	158	36
22						Cx		22,2	52	69	86	158	36	
						Sx	Dx	22,2	52	69	86	158	36	
						Dx	Sx	22,2	52	69	86	158	36	
28					7/8"	Cx		22,4	52	69	86	158	36	
						Sx	Dx	22,4	52	69	86	158	36	
						Dx	Sx	22,4	52	69	86	158	36	
		1 1/8"	Cx			28,2	52	69	86	158	36			
			Sx		Dx	28,2	52	69	86	158	36			
			Dx		Sx	28,2	52	69	86	158	36			
□35		1 3/4" -12 UN	28		1 1/8"	Cx		28,8	52	69	86	158	36	
						Sx	Dx	28,8	52	69	86	158	36	
						Dx	Sx	28,8	52	69	86	158	36	
					35	1 3/8"	Cx		28,8	52	75	98,5	201	50
							Sx	Dx	28,8	52	75	98,5	201	50
							Dx	Sx	28,8	52	75	98,5	201	50
	35		1 3/8"	Cx		35,2	52	75	98,5	201	50			
				Sx	Dx	35,2	52	75	98,5	201	50			
				Dx	Sx	35,2	52	75	98,5	201	50			

MASSIMA PRESSIONE DI LAVORO Maximum working pressure	PS 50 bar	PS 37 bar
TEMPERATURA AMMISSIBILE Permissible temperature	TS -10/+150 °C	TS -40/+150 °C
PRESSIONE DI COLLAUDO Testing pressure	PT 71,5 bar	
FLUIDO REFRIGERANTE Refrigerant	GROUP 2 PED	
CATEGORIA PED Category PED	ARTICLE 3.3	
TRATTAMENTO SUPERFICIALE: RAMATURA, NICHELATURA O STAGNATURA. Surface treatment: copper, nickel or tin plated.		

RUBINETTI AD ANGOLO A SALDARE -
Angle Valves to sold

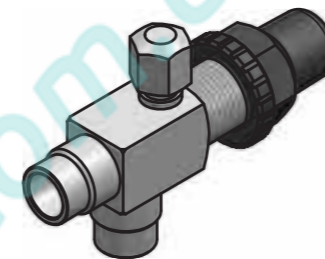
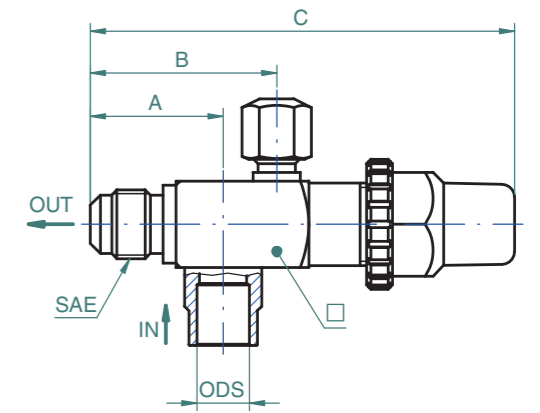
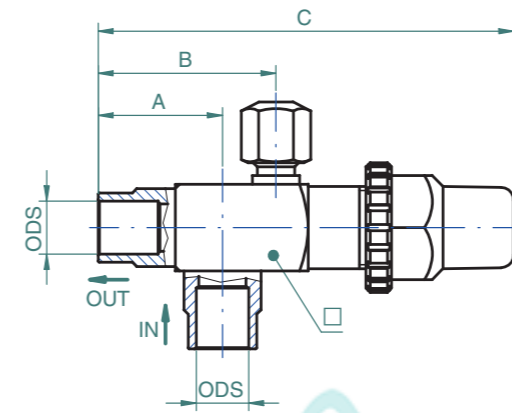

Attacco ODS in uscita e Presa Pressione tipo Cx
ODS outlet connection and Cx Gage port

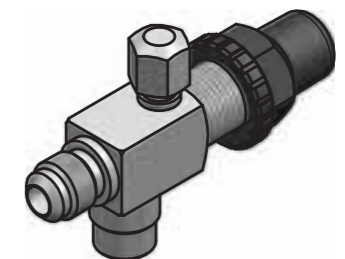

Attacco SAE in uscita e Presa Pressione tipo Cx
SAE outlet connection and Cx Gage port

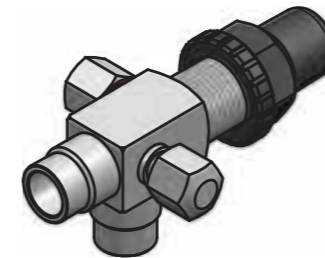

Pres. Pressione tipo Dx e Sx in By-Pass
Dx Gage port and Sx in By-Pass

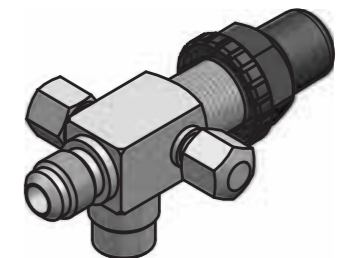

Pres. Pressione tipo Sx e Dx in By-Pass
Sx Gage port and Dx in By-Pass

□	Attacco IN		Attacco OUT		Pres. pressione	By-Pass	A	B	C	
	mm	inch.	mm	inch.						
□20	6	1/4"	6	1/4"	1/4"	Cx		26	38,5	94
						Sx	Dx	26	38,5	94
						Dx	Sx	26	38,5	94
		1/4"	Cx			26	38,5	94		
			Sx	Dx		26	38,5	94		
			Dx	Sx		26	38,5	94		
	8	1/4"	8	1/4"	1/4"	Cx		26	38,5	94
						Sx	Dx	26	38,5	94
						Dx	Sx	26	38,5	94

□	Attacco IN		Attacco OUT			Pres. pressione	By-Pass	A	B	C	
	ODS		ODS		SAE						
	mm	inch.	mm	inch.							
□20	8	3/8"		3/8"		Cx		26	38,5	94	
						Sx	Dx	26	38,5	94	
						Dx	Sx	26	38,5	94	
		3/8"		3/8"		Cx		26	38,5	94	
						Sx	Dx	26	38,5	94	
						Dx	Sx	26	38,5	94	
		10		10		Cx		26	38,5	94	
						Sx	Dx	26	38,5	94	
						Dx	Sx	26	38,5	94	
	12		12		Cx		29	41,5	97		
					Sx	Dx	29	41,5	97		
					Dx	Sx	29	41,5	97		
	1/2"	1/2"		1/2"		Cx		29	41,5	97	
						Sx	Dx	29	41,5	97	
						Dx	Sx	29	41,5	97	
		1/2"		1/2"		Cx		29	41,5	97	
						Sx	Dx	29	41,5	97	
						Dx	Sx	29	41,5	97	
		1/2"	1/2"		1/2"		Cx		29	41,5	97
							Sx	Dx	29	41,5	97
							Dx	Sx	29	41,5	97
	5/8"		5/8"	16	5/8"		Cx		37	51	120
							Sx	Dx	37	51	120
							Dx	Sx	37	51	120
5/8"				5/8"		Cx		37	51	120	
						Sx	Dx	37	51	120	
						Dx	Sx	37	51	120	
18		18	18			Cx		37	51	120	
						Sx	Dx	37	51	120	
						Dx	Sx	37	51	120	
	3/4"		3/4"			Cx		37	51	120	
						Sx	Dx	37	51	120	
						Dx	Sx	37	51	120	
	3/4"	18		3/4"		Cx		37	51	120	
						Sx	Dx	37	51	120	
						Dx	Sx	37	51	120	
3/4"			3/4"			Cx		37	51	120	
						Sx	Dx	37	51	120	
						Dx	Sx	37	51	120	
□30		22	22			Cx		40	57	129	
						Sx	Dx	40	57	129	
						Dx	Sx	40	57	129	
	7/8"		7/8"			Cx		40	57	129	
						Sx	Dx	40	57	129	
						Dx	Sx	40	57	129	
	22		3/4"			Cx		40	57	129	
						Sx	Dx	40	57	129	
						Dx	Sx	40	57	129	
	7/8"		3/4"			Cx		40	57	129	
						Sx	Dx	40	57	129	
						Dx	Sx	40	57	129	

□	Attacco IN		Attacco OUT			Pres. pressione	By-Pass	A	B	C
	ODS		ODS		SAE					
	mm	inch.	mm	inch.						
□35	28		28			Cx		56	79,5	182
						Sx	Dx	56	79,5	182
						Dx	Sx	56	79,5	182
						Cx		56	79,5	182
						Sx	Dx	56	79,5	182
						Dx	Sx	56	79,5	182
	35	1 3/8"	35	1 3/8"		Cx		58	81,5	184
						Sx	Dx	58	81,5	184
						Dx	Sx	58	81,5	184
						Cx		61	84,5	187
						Sx	Dx	61	84,5	187
						Dx	Sx	61	84,5	187
	42	1 5/8"	42	1 5/8"		Cx		61	84,5	187
						Sx	Dx	61	84,5	187
						Dx	Sx	61	84,5	187
						Cx		61	84,5	187
						Sx	Dx	61	84,5	187
						Dx	Sx	61	84,5	187
□45	35	1 3/8"	35	1 3/8"		Cx		64	91	199
						Sx	Dx	64	91	199
						Dx	Sx	64	91	199
	1 5/8"		1 5/8"			Cx		69	96	204
						Sx	Dx	69	96	204
						Dx	Sx	69	96	204
	42		42			Cx		69	96	204
						Sx	Dx	69	96	204
						Dx	Sx	69	96	204
	54	2 1/8"	54	2 1/8"		Cx		74	101	209
						Sx	Dx	74	101	209
						Dx	Sx	74	101	209

MASSIMA PRESSIONE DI LAVORO Maximum working pressure	PS 50 bar	PS 37 bar
TEMPERATURA AMMISSIBILE Permissible temperature	TS -10/+150 °C	TS -40/+150 °C
PRESSIONE DI COLLAUDO Testing pressure	PT 71,5 bar	
FLUIDO REFRIGERANTE Refrigerant	GROUP 2 PED	
CATEGORIA PED Category PED	ARTICLE 3.3	
TRATTAMENTO SUPERFICIALE: RAMATURA, NICHELATURA O STAGNATURA. Surface treatment: copper, nickel or tin plated.		

RUBINETTI AD ANGOLO PER CO₂ (R744)
Angle Valves for CO₂ (R744)

□ mm	ODS mm	ODS inch	A mm	B mm	C mm	D mm	E mm
□20	6	/	26	38,5	94	8	25
	/	1/4"	26	38,5	94	8	25
	8	/	26	38,5	94	8	25
	/	3/8"	26	38,5	94	10	25
	10	/	26	38,5	94	10	25
	12	/	29	41,5	97	14	28
	/	1/2"	29	41,5	97	14	28
	16	5/8"	29	41,5	97	15	28
□22	18	/	31	43,5	99	16	30
	/	3/4"	31	43,5	99	16	30
	16	5/8"	37	51	120	15	33
	18	/	37	51	120	15	33
□30	22	/	42	56	125	17	36
	/	7/8"	42	56	125	17	36
	16	5/8"	40	57	129	15	38
	18	/	40	57	129	15	38
□35	22	/	56	79,5	182	20	50,5
	/	7/8"	56	79,5	182	20	50,5
	28	/	56	79,5	182	20	50,5
	/	1 1/8"	56	79,5	182	20	50,5
□45	35	1 3/8"	58	81,5	184	22	52,5
	/	1 5/8"	61	84,5	187	25	52,5
	42	/	61	84,5	187	25	52,5
	/	1 5/8"	69	96	204	25	62,5
□45	42	/	69	96	204	25	62,5
	54	2 1/8"	74	101	209	30	67,5

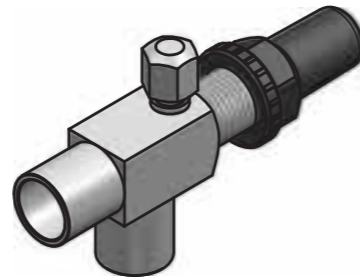
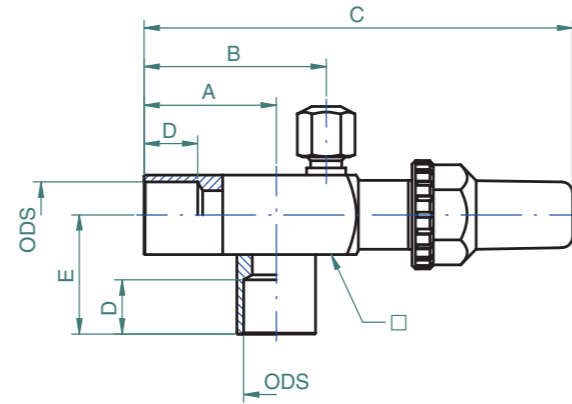

VALVOLE NPT ORIZZONTALI - NPT horizontal Valves

□ mm	ODS mm	ODS inch	NPT	A mm	B mm	C mm	D mm	E mm
□20	6	/	1/4"	26	38,5	94	8	30
	/	1/4"	1/4"	26	38,5	94	8	30
	8	/	3/8"	26	38,5	94	10	30
	/	3/8"	3/8"	26	38,5	94	10	30
10	/	3/8"	26	38,5	94	10	30	

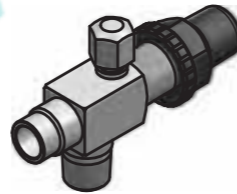
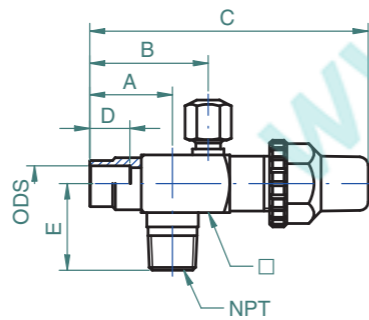

VALVOLE NPT VERTICALI - NPT vertical Valves

□ mm	ODS mm	ODS inch	NPT	A mm	B mm	C mm	D mm	E mm
□20	/	3/8"	3/8"	31	/	99	10	25
	10	/	3/8"	31	/	99	10	25

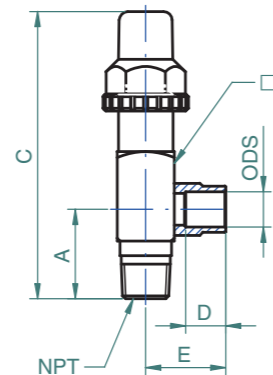

MASSIMA PRESSIONE DI LAVORO Maximum working pressure	PS 150 bar
PRESSIONE DI COLLAUDO Testing pressure	PT 215 bar
TEMPERATURA AMMISSIBILE Permissible temperature	TS -20/+200 °C
FLUIDO REFRIGERANTE Refrigerant	GROUP 2 PED
CATEGORIA PED Category PED	ARTICLE 3.3
TRATTAMENTO SUPERFICIALE: RAMATURA, NICHILATURA O STAGNATURA. Surface treatment: copper, nickel or tin plated.	

RUBINETTI FLANGIATI CON ATTACCO FLARE (SAE) IN USCITA
Flanged valves with outlet flare connection (SAE)

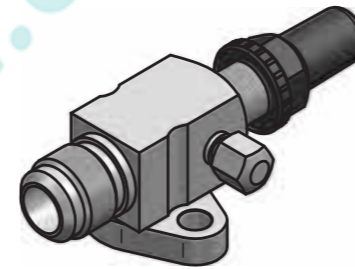
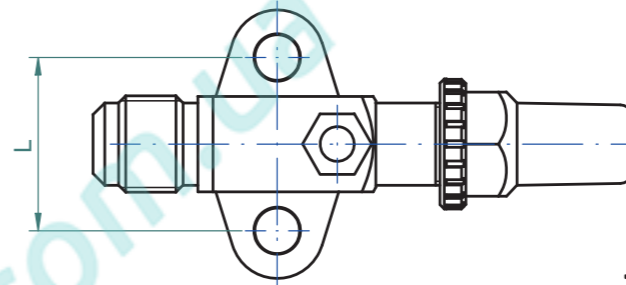
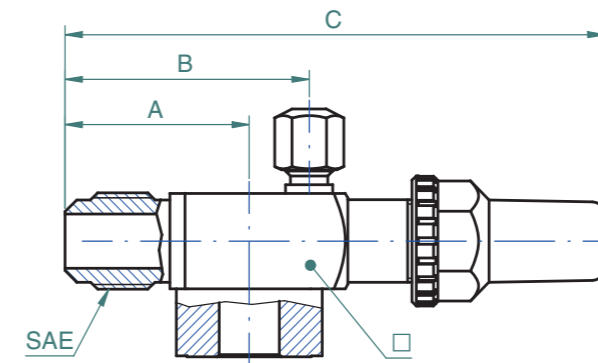

Presse Pressione tipo Sx
Sx Gage port

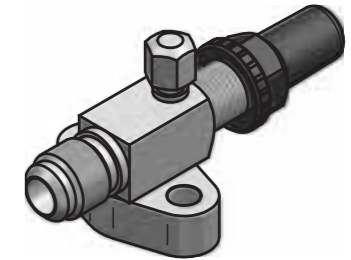

Presse Pressione tipo Cx
Cx Gage port

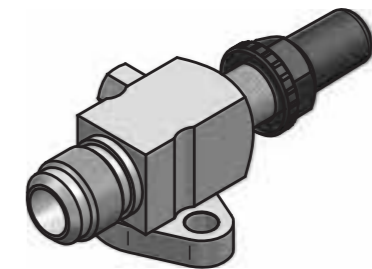

Presse Pressione tipo Dx
Dx Gage port

Interasse flangia L	□	Uscita SAE	Presse pressione	A	B	C
mm	mm		Cx-Sx-Dx	mm	mm	mm
35	□20	1/4" SAE	Cx	25,5	38	90
		3/8" SAE	Cx	30,5	43	95
		1/2" SAE	Cx	33,5	46	98
	□22	5/8" SAE	Cx	36,5	49	101
		5/8" SAE	Cx	43	57	124
		3/4" SAE	Cx	47	61	128
41,3	□20	1/4" SAE	Cx	25,5	38	90
		3/8" SAE	Cx	30,5	43	95
		1/2" SAE	Cx	33,5	46	98
		5/8" SAE	Cx	36,5	49	101
	□22	5/8" SAE	Cx	43	57	124
		3/4" SAE	Cx	47	61	128
	□30	5/8" SAE	Cx	45	62	134
			Sx	45	62	134
			Dx	45	62	134
		3/4" SAE	Cx	45	62	134
			Sx	45	62	134
			Dx	45	62	134

Interasse flangia L	□	Uscita SAE	Presse pressione	A	B	C
mm	mm		Cx-Sx-Dx	mm	mm	mm
55	□30	5/8" SAE	Cx	45	62	134
			Sx	45	62	134
			Dx	45	62	134
		3/4" SAE	Cx	45	62	134
			Sx	45	62	134
			Dx	45	62	134
66	□30	5/8" SAE	Cx	45	62	134
			Sx	45	62	134
			Dx	45	62	134
		3/4" SAE	Cx	45	62	134
			Sx	45	62	134
			Dx	45	62	134

MASSIMA PRESSIONE DI LAVORO Maximum working pressure	PS 50 bar	PS 37 bar
TEMPERATURA AMMISSIBILE Permissible temperature	TS -10/+150 °C	TS -40/+150 °C
PRESSIONE DI COLLAUDO Testing pressure	PT 71,5 bar	
FLUIDO REFRIGERANTE Refrigerant	GROUP 2 PED	
CATEGORIA PED Category PED	ARTICLE 3.3	
TRATTAMENTO SUPERFICIALE: RAMATURA, NICHELATURA O STAGNATURA. Surface treatment: copper, nickel or tin plated.		

RUBINETTI FLANGIATI CON ATTACCO ODS IN USCITA Flanged valves with outlet ODS

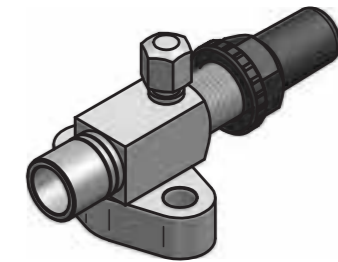
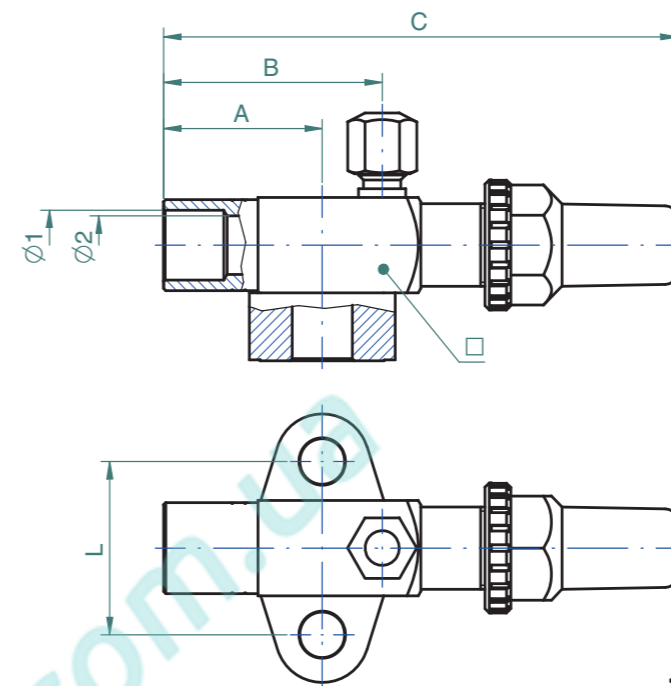

Presse Pressione tipo Cx
Cx Gage port

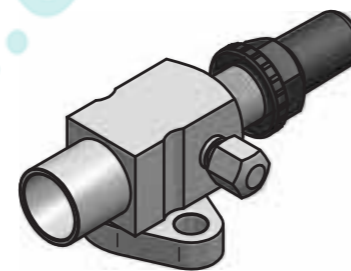

Presse Pressione tipo Sx
Sx Gage port

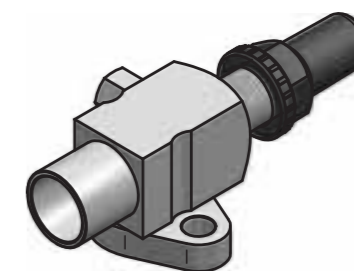

Presse Pressione tipo Dx
DX Gage port

Interasse flangia L	□	Uscita ODS	Uscita ODS	Presse pressione	Ø1	Ø2	A	B	C	
mm	mm	mm	inch	Cx-Sx-Dx	mm	mm	mm	mm	mm	
35	□20	6		Cx	6,2	5	26	38,5	94	
			1/4"	Cx	6,45	5,5	26	38,5	94	
		8		Cx	8,2	7	26	38,5	94	
			3/8"	Cx	9,7	8,5	26	38,5	94	
		10		Cx	10,2	9	26	38,5	94	
		12		Cx	12,25	11	29	41,5	97	
	□22			1/2"	Cx	12,95	11	29	41,5	97
		16		5/8"	Cx	16,2	11	29	41,5	97
		16		5/8"	Cx	16,2	13,5	37	51	120
		18			Cx	18,25	13,5	37	51	120
				3/4"	Cx	19,3	13,5	37	51	120
41,3	□20		3/8"	Cx	9,7	8,5	26	38,5	94	
		10		Cx	10,2	9	26	38,5	94	
		12		Cx	12,95	11	29	41,5	97	
	□22			1/2"	Cx	12,95	11	29	41,5	97
		16		5/8"	Cx	16,2	13,5	37	51	120
		18			Cx	18,25	13,5	37	51	120
				3/4"	Cx	19,3	13,5	37	51	120
		22			Cx	22,25	13,5	42	56	125
			7/8"	Cx	22,45	18	42	56	125	

Interasse flangia L	□	Uscita ODS	Uscita ODS	Pres. pressione	Ø1	Ø2	A	B	C	
mm	mm	mm	inch	Cx-Sx-Dx	mm	mm	mm	mm	mm	
41,3	□30	22		Cx	22,25	18	40	57	129	
				Sx	22,25	18	40	57	129	
				Dx	22,25	18	40	57	129	
		7/8"		Cx	22,45	18	40	57	129	
				Sx	22,45	18	40	57	129	
				Dx	22,45	18	40	57	129	
		28		Cx	28,3	18	53	70	142	
				Sx	28,3	18	53	70	142	
				Dx	28,3	18	53	70	142	
		1 1/8"		Cx	28,85	18	53	70	142	
				Sx	28,85	18	53	70	142	
				Dx	28,85	18	53	70	142	
55	□30	22		Cx	22,25	18	40	57	129	
				Sx	22,25	18	40	57	129	
				Dx	22,25	18	40	57	129	
		7/8"		Cx	22,45	18	40	57	129	
				Sx	22,45	18	40	57	129	
				Dx	22,45	18	40	57	129	
		28		Cx	28,3	18	53	70	142	
				Sx	28,3	18	53	70	142	
				Dx	28,3	18	53	70	142	
		1 1/8"		Cx	28,85	18	53	70	142	
				Sx	28,85	18	53	70	142	
				Dx	28,85	18	53	70	142	
□35	28		Cx	28,3	26,5	56	79,5	182		
			Sx	28,3	26,5	56	79,5	182		
			Dx	28,3	26,5	56	79,5	182		
	1 1/8"		Cx	28,85	26,5	56	79,5	142		
			Sx	28,85	26,5	56	79,5	142		
			Dx	28,85	26,5	56	79,5	142		
	35	1 3/8"	Cx	35,3	26,5	58	81,5	184		
			Sx	35,3	26,5	58	81,5	184		
			Dx	35,3	26,5	58	81,5	184		
	66	□30	28		Cx	28,3	18	53	70	142
					Sx	28,3	18	53	70	142
					Dx	28,3	18	53	70	142
1 1/8"				Cx	28,85	18	53	70	142	
				Sx	28,85	18	53	70	142	
				Dx	28,85	18	53	70	142	
□35			28		Cx	28,3	26,5	56	79,5	182
					Sx	28,3	26,5	56	79,5	182
					Dx	28,3	26,5	56	79,5	182
			1 1/8"		Cx	28,85	26,5	56	79,5	142
					Sx	28,85	26,5	56	79,5	142
					Dx	28,85	26,5	56	79,5	142
	35	1 3/8"	Cx	35,3	26,5	58	81,5	184		
			Sx	35,3	26,5	58	81,5	184		
			Dx	35,3	26,5	58	81,5	184		
	1 5/8"		Cx	41,6	26,5	61	84,5	187		
			Sx	41,6	26,5	61	84,5	187		
			Dx	41,6	26,5	61	84,5	187		
42		Cx	42,35	26,5	61	84,5	187			
		Sx	42,35	26,5	61	84,5	187			
		Dx	42,35	26,5	61	84,5	187			

Interasse flangia L	□	Uscita ODS	Uscita ODS	Pres. pressione	Ø1	Ø2	A	B	C
mm	mm	mm	inch	Cx-Sx-Dx	mm	mm	mm	mm	mm
70	□35	28		Cx	28,3	26,5	56	79,5	182
				Sx	28,3	26,5	56	79,5	182
				Dx	28,3	26,5	56	79,5	182
		1 1/8"		Cx	28,85	26,5	56	79,5	142
				Sx	28,85	26,5	56	79,5	142
				Dx	28,85	26,5	56	79,5	142
		35	1 3/8"	Cx	35,3	26,5	58	81,5	184
				Sx	35,3	26,5	58	81,5	184
				Dx	35,3	26,5	58	81,5	184
		1 5/8"		Cx	41,6	26,5	61	84,5	187
				Sx	41,6	26,5	61	84,5	187
				Dx	41,6	26,5	61	84,5	187
42		Cx	42,35	26,5	61	84,5	187		
		Sx	42,35	26,5	61	84,5	187		
		Dx	42,35	26,5	61	84,5	187		

MASSIMA PRESSIONE DI LAVORO Maximum working pressure	PS 50 bar	PS 37 bar
TEMPERATURA AMMISSIBILE Permissible temperature	TS -10/+150 °C	TS -40/+150 °C
PRESSIONE DI COLLAUDO Testing pressure	PT 71,5 bar	
FLUIDO REFRIGERANTE Refrigerant	GROUP 2 PED	
CATEGORIA PED Category PED	ARTICLE 3.3	
TRATTAMENTO SUPERFICIALE: RAMATURA, NICHELATURA O STAGNATURA. Surface treatment: copper, nickel or tin plated.		

RUBINETTI FLANGIATI CON ATTACCO ODS IN USCITA IN RAME
Flanged valves with copper outlet ODS

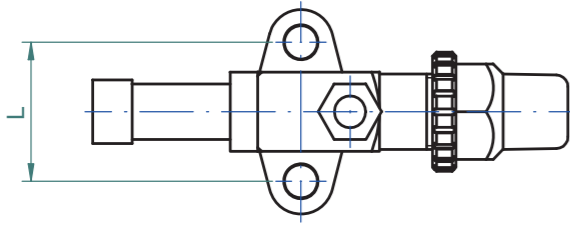
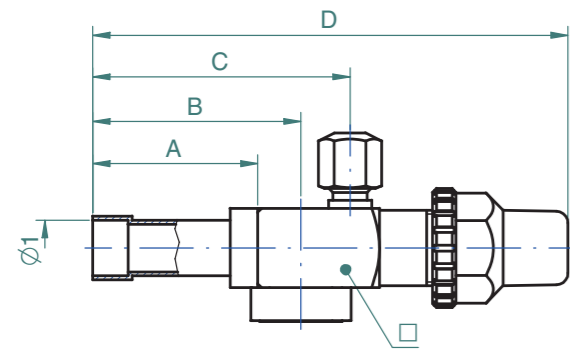

Raccordo Schrader 1/4" SAE
 1/4" SAE Schrader connection

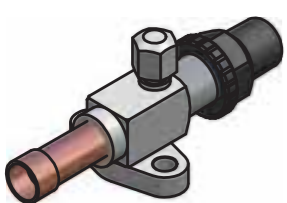

Presse Pressioe tipo Cx
 Cx Gage port

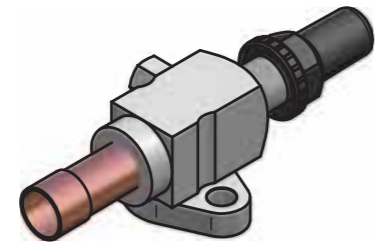

Presse Pressioe tipo Dx
 Dx Gage port

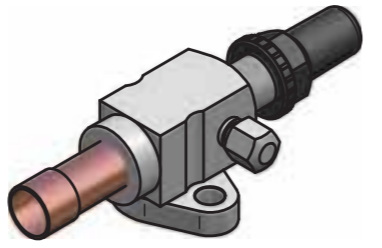

Presse Pressioe tipo Sx
 Sx Gage port

Interasse flangia L	□	Uscita ODS	Uscita ODS	Presse pressione	Ø1	A	B	C	D
mm	mm	mm	inch	Cx-Sx-Dx	mm	mm	mm	mm	mm
35	□20	6		Cx	6,2	35	46	58,5	114
			1/4"	Cx	6,5	35	46	58,5	114
		8		Cx	8,2	35	46	58,5	114
			3/8"	Cx	9,7	35	46	58,5	114
		10		Cx	10,2	35	46	58,5	114
		12		Cx	12,2	35	46	58,5	114
		1/2"	Cx	12,8	35	46	58,5	114	
	16	5/8"	Cx	16,2	35	46	58,5	114	
	□22	16	5/8"	Cx	16,2	35	50	64	133
		18		Cx	18,2	52	67	81	150
		3/4"	Cx	19,2	52	67	81	150	
		3/8"	Cx	9,7	35	46	58,5	114	
41,3	□20	10		Cx	10,2	35	46	58,5	114
		12		Cx	12,2	35	46	58,5	114
			1/2"	Cx	12,8	35	46	58,5	114
		16	5/8"	Cx	16,2	35	50	64	133
	□22	18		Cx	18,2	52	67	81	150
			3/4"	Cx	19,2	52	67	81	150
		22		Cx	22,2	52	67	81	150
			7/8"	Cx	22,4	52	67	81	150

Interasse flangia L	□	Uscita ODS	Uscita ODS	Presse pressione	Ø1	A	B	C	D
mm	mm	mm	inch	Cx-Sx-Dx	mm	mm	mm	mm	mm
41,3	□30	22		Cx	22,2	52	69	86	158
				Sx	22,2	52	69	86	158
				Dx	22,2	52	69	86	158
		7/8"		Cx	22,4	52	69	86	158
				Sx	22,4	52	69	86	158
				Dx	22,4	52	69	86	158
		28		Cx	28,2	52	69	86	158
				Sx	28,2	52	69	86	158
				Dx	28,2	52	69	86	158
		1 1/8"		Cx	28,8	52	69	86	158
				Sx	28,8	52	69	86	158
				Dx	28,8	52	69	86	158
55	□30	22		Cx	22,2	52	69	86	158
				Sx	22,2	52	69	86	158
				Dx	22,2	52	69	86	158
		7/8"		Cx	22,4	52	69	86	158
				Sx	22,4	52	69	86	158
				Dx	22,4	52	69	86	158
		28		Cx	28,2	52	69	86	158
				Sx	28,2	52	69	86	158
				Dx	28,2	52	69	86	158
		1 1/8"		Cx	28,8	52	69	86	158
				Sx	28,8	52	69	86	158
				Dx	28,8	52	69	86	158
	□35	28		Cx	28,2	52	75	98,5	201
				Sx	28,2	52	75	98,5	201
				Dx	28,2	52	75	98,5	201
		1 1/8"		Cx	28,8	52	75	98,5	201
				Sx	28,8	52	75	98,5	201
				Dx	28,8	52	75	98,5	201
35	1 3/8"		Cx	35,2	52	75	98,5	201	
			Sx	35,2	52	75	98,5	201	
			Dx	35,2	52	75	98,5	201	
66	□30	28		Cx	28,2	52	69	86	158
				Sx	28,2	52	69	86	158
				Dx	28,2	52	69	86	158
		1 1/8"		Cx	28,8	52	69	86	158
				Sx	28,8	52	69	86	158
				Dx	28,8	52	69	86	158
	□35	28		Cx	28,2	52	75	98,5	201
				Sx	28,2	52	75	98,5	201
				Dx	28,2	52	75	98,5	201
		1 1/8"		Cx	28,8	52	75	98,5	201
				Sx	28,8	52	75	98,5	201
				Dx	28,8	52	75	98,5	201
	35	1 3/8"		Cx	35,2	52	75	98,5	201
				Sx	35,2	52	75	98,5	201
				Dx	35,2	52	75	98,5	201

Interasse flangia L	□	Uscita ODS	Uscita ODS	Pres. pressione	Ø1	A	B	C	D
mm	mm	mm	inch	Cx-Sx-Dx	mm	mm	mm	mm	mm
70	□35	28	1 1/8"	Cx	28,2	52	75	98,5	201
				Sx	28,2	52	75	98,5	201
				Dx	28,2	52	75	98,5	201
		Cx		28,8	52	75	98,5	201	
		Sx		28,8	52	75	98,5	201	
		Dx		28,8	52	75	98,5	201	
	35	1 3/8"	Cx	35,2	52	75	98,5	201	
			Sx	35,2	52	75	98,5	201	
			Dx	35,2	52	75	98,5	201	

MASSIMA PRESSIONE DI LAVORO Maximum working pressure	PS 50 bar	PS 37 bar
TEMPERATURA AMMISSIBILE Permissible temperature	TS -10/+150 °C	TS -40/+150 °C
PRESSIONE DI COLLAUDO Testing pressure	PT 71,5 bar	
FLUIDO REFRIGERANTE Refrigerant	GROUP 2 PED	
CATEGORIA PED Category PED	ARTICLE 3.3	
TRATTAMENTO SUPERFICIALE: RAMATURA, NICHELATURA O STAGNATURA. Surface treatment: copper, nickel or tin plated.		

RUBINETTI A FLANGIA PER CO2 - Flanged valves for CO2 (R744)

- RUBINETTI □22 FLANGIA OVALE
- Valves □22 oval flanges

H	L1	L2	L3	ODS	ODS
mm	mm	mm	mm	mm	inch
40	120	51	37	16	5/8"
	125	56	42	18	/
	125	56	42	/	3/4"

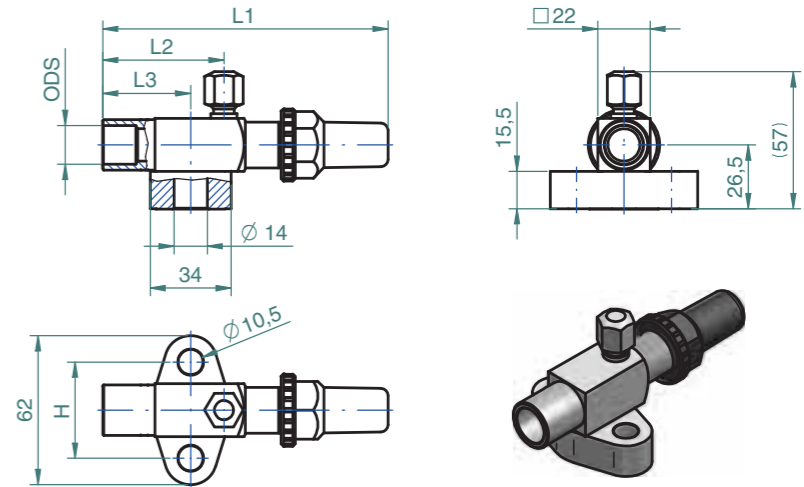

- RUBINETTI □30 FLANGIA QUADRA
- Valves □30 square flanges

H	L1	L2	L3	ODS	ODS
mm	mm	mm	mm	mm	inch
45	150	77	60	22	/
	150	77	60	/	7/8"
	160	87	70	28	/
	160	87	70	/	1 1/8"
55	161	88	71	22	/
	161	88	71	/	7/8"
	165	92	75	28	/
	165	92	75	/	1 1/8"

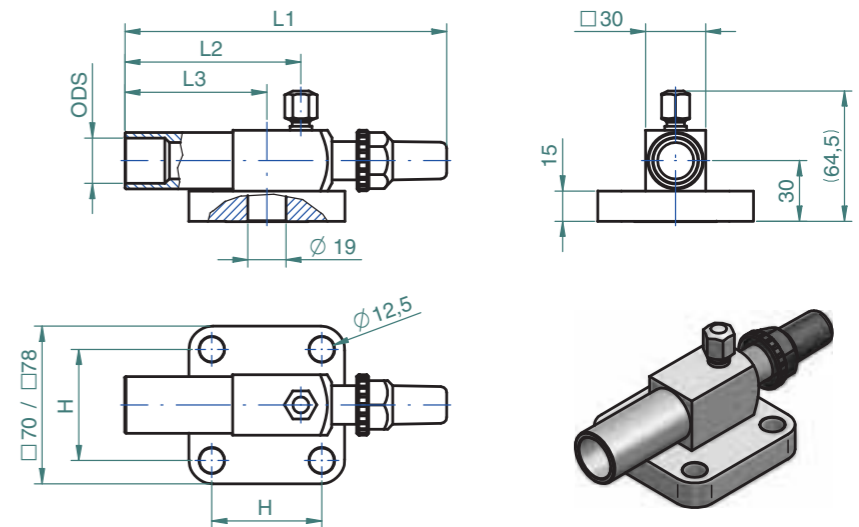

- RUBINETTI □35 FLANGIA QUADRA
- Valves □35 square flanges

H	L1	L2	L3	ODS	ODS
mm	mm	mm	mm	mm	inch
55	188	86,5	63	28	/
	188	86,5	63	/	1 1/8"
	200	98,5	75	35	1 3/8"
63,5	195	93,5	70	28	/
	195	93,5	70	/	1 1/8"
	207	105,5	82	35	1 3/8"

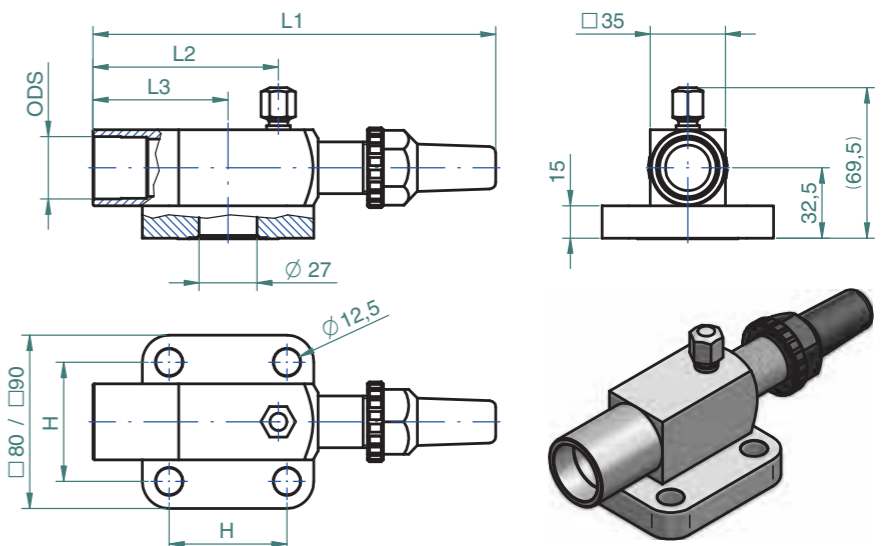

MASSIMA PRESSIONE DI LAVORO Maximum working pressure	PS 150 bar
PRESSIONE DI COLLAUDO Testing pressure	PT 215 bar
TEMPERATURA AMMISSIBILE Permissible temperature	TS -20/+200 °C
FLUIDO REFRIGERANTE Refrigerant	GROUP 2 PED
CATEGORIA PED Category PED	ARTICLE 3.3
TRATTAMENTO SUPERFICIALE: RAMATURA, NICHELATURA O STAGNATURA. Surface treatment: copper, nickel or tin plated.	

RUBINETTI ORIZZONTALI TIPO ROTALOCK CON ATTACCO IN USCITA O-RING - Horizontal Rotalock Valves with O-Ring outlet

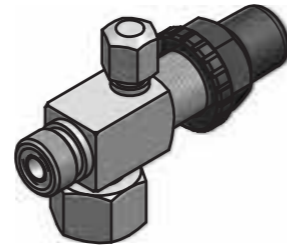
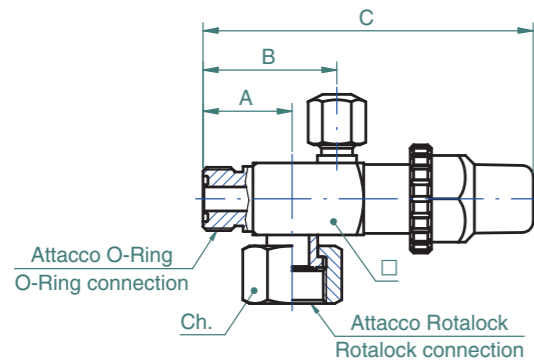

□	Attacco Rotalock	Uscita O-Ring	A	B	C	Ch.
mm			mm	mm	mm	mm
□20	3/4" - 16 UNF	1/4"	25	37,5	93	24
	3/4" - 16 UNF	3/8"	25	37,5	93	24
□22	1 - 14" UNS	1/2"	30	42,5	98	30
	1 - 14" UNS	5/8"	37	51	120	30
□30	1 1/4" -12 UNS	3/4"	40	57	130	36

RUBINETTI ORIZZONTALI TIPO ROTALOCK CON ATTACCO IN USCITA ROTALOCK - Horizontal Rotalock Valves with Rotalock outlet

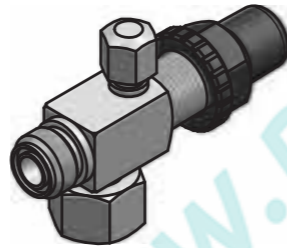
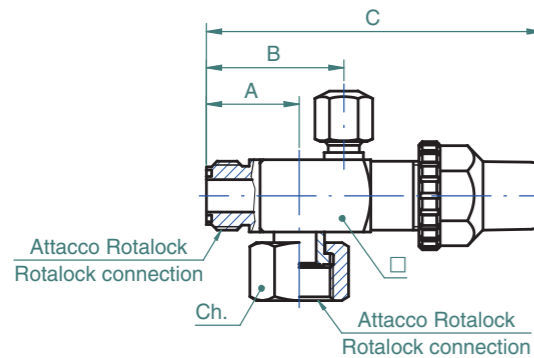

□	Attacco Rotalock	Uscita Rotalock	A	B	C	Ch.
mm			mm	mm	mm	mm
□20	3/4" - 16 UNF	3/4" - 16 UNF	26	38,5	94	24
□20	1 - 14" UNS	1 - 14" UNS	29	41,5	97	30
□22	1 - 14" UNS	1 - 14" UNS	33	47,5	116	30
□30	1 1/4" -12 UNS	1 - 14" UNS	40,5	57,5	130	36
□35	1 3/4" -12 UNS	1 3/4" -12 UNS	46,5	70	172	50
□45	2 1/4" -12 UNS	2 1/4" -12 UNS	69	96	204	65

MASSIMA PRESSIONE DI LAVORO Maximum working pressure	PS 50 bar	PS 37 bar
TEMPERATURA AMMISSIBILE Permissible temperature	TS -10/+150 °C	TS -40/+150 °C
PRESSIONE DI COLLAUDO Testing pressure	PT 71,5 bar	
FLUIDO REFRIGERANTE Refrigerant	GROUP 2 PED	
CATEGORIA PED Category PED	ARTICLE 3.3	
TRATTAMENTO SUPERFICIALE: RAMATURA, NICHELATURA O STAGNATURA. Surface treatment: copper, nickel or tin plated.		

RUBINETTI PER BASAMENTI - Valves for panels

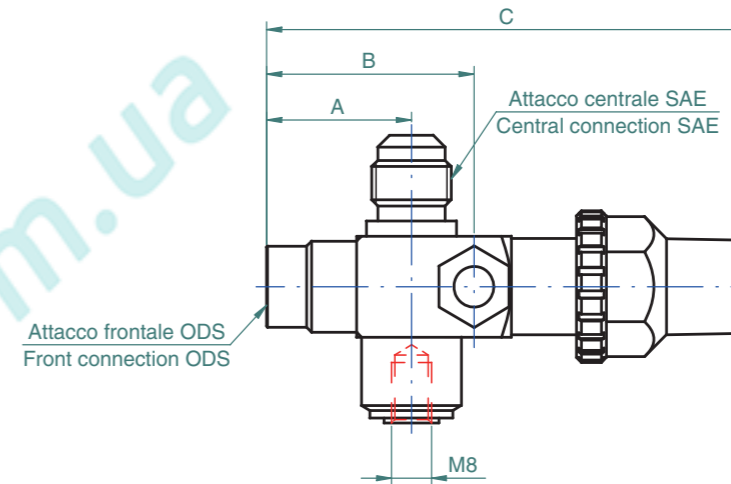
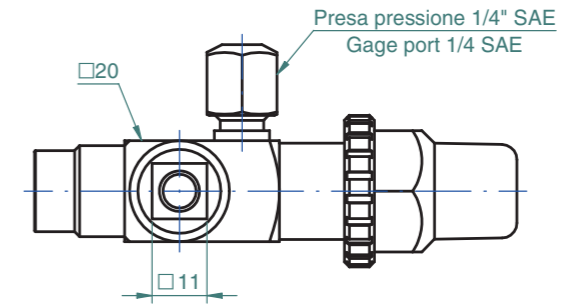

Presa Pressione tipo Sx
Sx Gage port



Presa Pressione tipo Dx
Dx Gage port

Attacco centrale Central connection	Attacco frontale ODS Front connection ODS	
	mm	inch.
1/4" SAE	6	1/4"
3/8" SAE	8 - 10	3/8"
1/2" SAE	12	1/2"
5/8" SAE	16	5/8"

MASSIMA PRESSIONE DI LAVORO Maximum working pressure	PS 50 bar	PS 37 bar
TEMPERATURA AMMISSIBILE Permissible temperature	TS -10/+150 °C	TS -40/+150 °C
PRESSIONE DI COLLAUDO Testing pressure	PT 71,5 bar	
FLUIDO REFRIGERANTE Refrigerant	GROUP 2 PED	
CATEGORIA PED Category PED	ARTICLE 3.3	
TRATTAMENTO SUPERFICIALE: RAMATURA, NICHELATURA O STAGNATURA. Surface treatment: copper, nickel or tin plated.		

RUBINETTI VERTICALI CON STAFFA, INGRESSO ODS, USCITA ODS O SAE - Vertical Valves with bracket, ODS inlet and ODS or SAE outlet

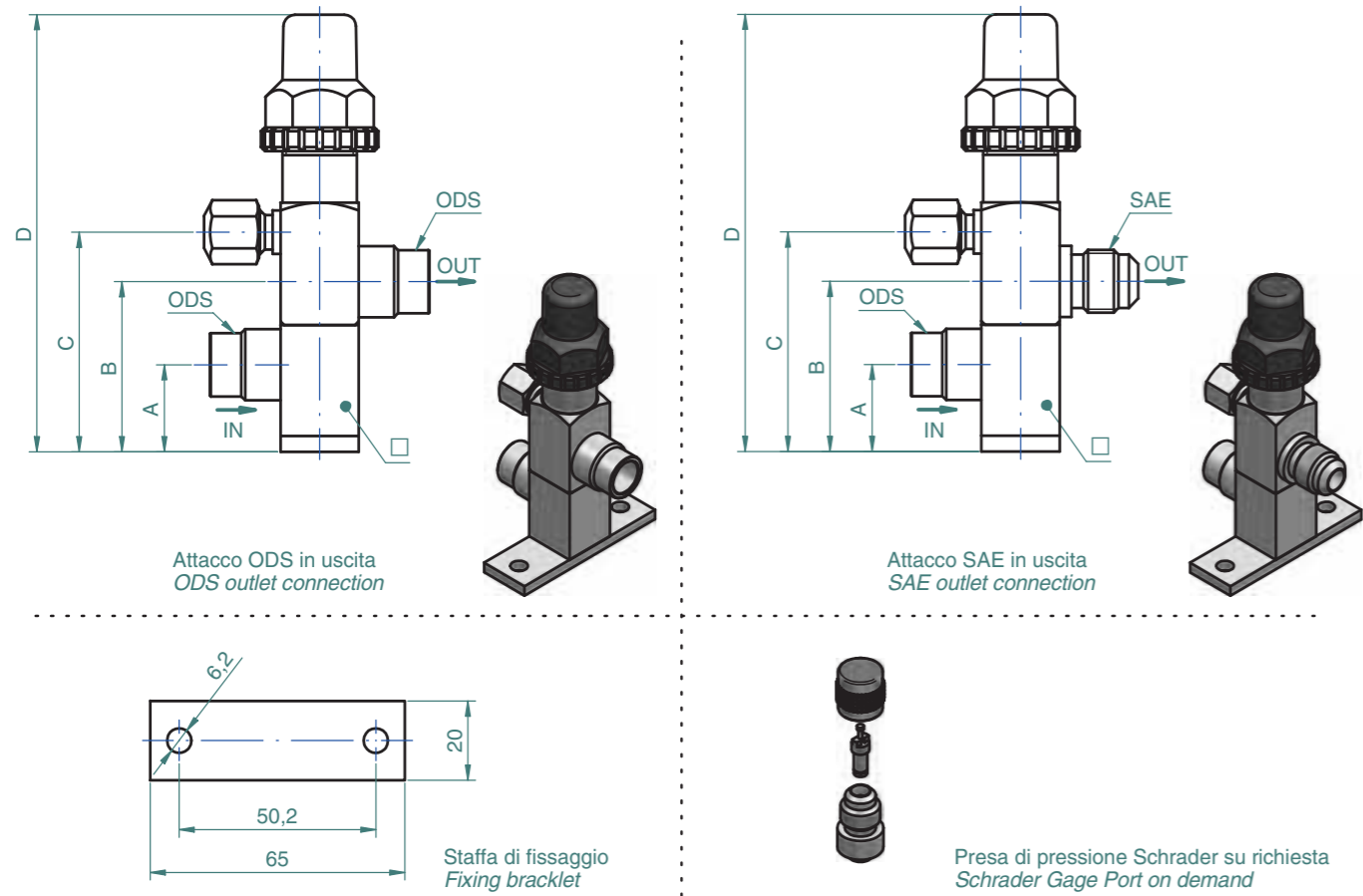

□	Attacco IN		Attacco OUT			A	B	C	D	
	ODS		ODS	SAE						
mm	mm	inch.	mm	inch.		mm	mm	mm	mm	
□20	6	1/4"			1/4"	22	43	55,5	111	
			6			22	43	55,5	111	
				1/4"		22	43	55,5	111	
	8 - 10	3/8"		8			22	43	55,5	111
					3/8"		22	43	55,5	111
					3/8"		22	43	55,5	111
			10			22	43	55,5	111	
					1/2"		22	43	55,5	111
			12			22	43	55,5	111	
	12	1/2"			5/8"		22	43	55,5	111
				16	5/8"		22	43	55,5	111
					3/8"		22	43	55,5	111
					3/8"		22	43	55,5	111
			10			22	43	55,5	111	
					1/2"		22	43	55,5	111
			12			22	43	55,5	111	
					1/2"		22	43	55,5	111
					5/8"		22	43	55,5	111
	16	5/8"		22	43	55,5	111			
	18			22	43	55,5	111			
		3/4"		22	43	55,5	111			

□	Attacco IN		Attacco OUT			A	B	C	D	
	ODS		ODS		SAE					
mm	mm	inch.	mm	inch.		mm	mm	mm	mm	
□22	12	1/2"			1/2"	23	49	63	132	
			12			23	49	63	132	
				1/2"		23	49	63	132	
					5/8"	23	49	63	132	
			16	5/8"		23	49	63	132	
	16	5/8"	5/8"				23	49	63	132
				16	5/8"		23	49	63	132
				18			23	49	63	132
					3/4"		23	49	63	132
				22			23	49	63	132
□30	18	3/4"				30	62	79	151	
			18			30	62	79	151	
				3/4"		30	62	79	151	
			22			30	62	79	151	
				7/8"		30	62	79	151	
	22	7/8"	3/4"				30	62	79	151
				18			30	62	79	151
					3/4"		30	62	79	151
				22			30	62	79	151
					7/8"		30	62	79	151
□35	22	7/8"				36	82	105,5	208	
			22			36	82	105,5	208	
				7/8"		36	82	105,5	208	
			28			36	82	105,5	208	
				1 1/8"		36	82	105,5	208	
	28	1 1/8"	1 1/8"				36	82	105,5	208
				28			36	82	105,5	208
					1 1/8"		36	82	105,5	208
				35	1 3/8"		36	82	105,5	208
					1 5/8"		36	82	105,5	208
	42			36	82	105,5	208			

MASSIMA PRESSIONE DI LAVORO Maximum working pressure	PS 50 bar	PS 37 bar
TEMPERATURA AMMISSIBILE Permissible temperature	TS -10/+150 °C	TS -40/+150 °C
PRESSIONE DI COLLAUDO Testing pressure	PT 71,5 bar	
FLUIDO REFRIGERANTE Refrigerant	GROUP 2 PED	
CATEGORIA PED Category PED	ARTICLE 3.3	
TRATTAMENTO SUPERFICIALE: RAMATURA, NICHELATURA O STAGNATURA. Surface treatment: copper, nickel or tin plated.		

RUBINETTI VERTICALI CON STAFFA, INGRESSO SAE, USCITA SAE O ODS - Vertical Valves with bracket, SAE inlet and SAE or ODS outlet

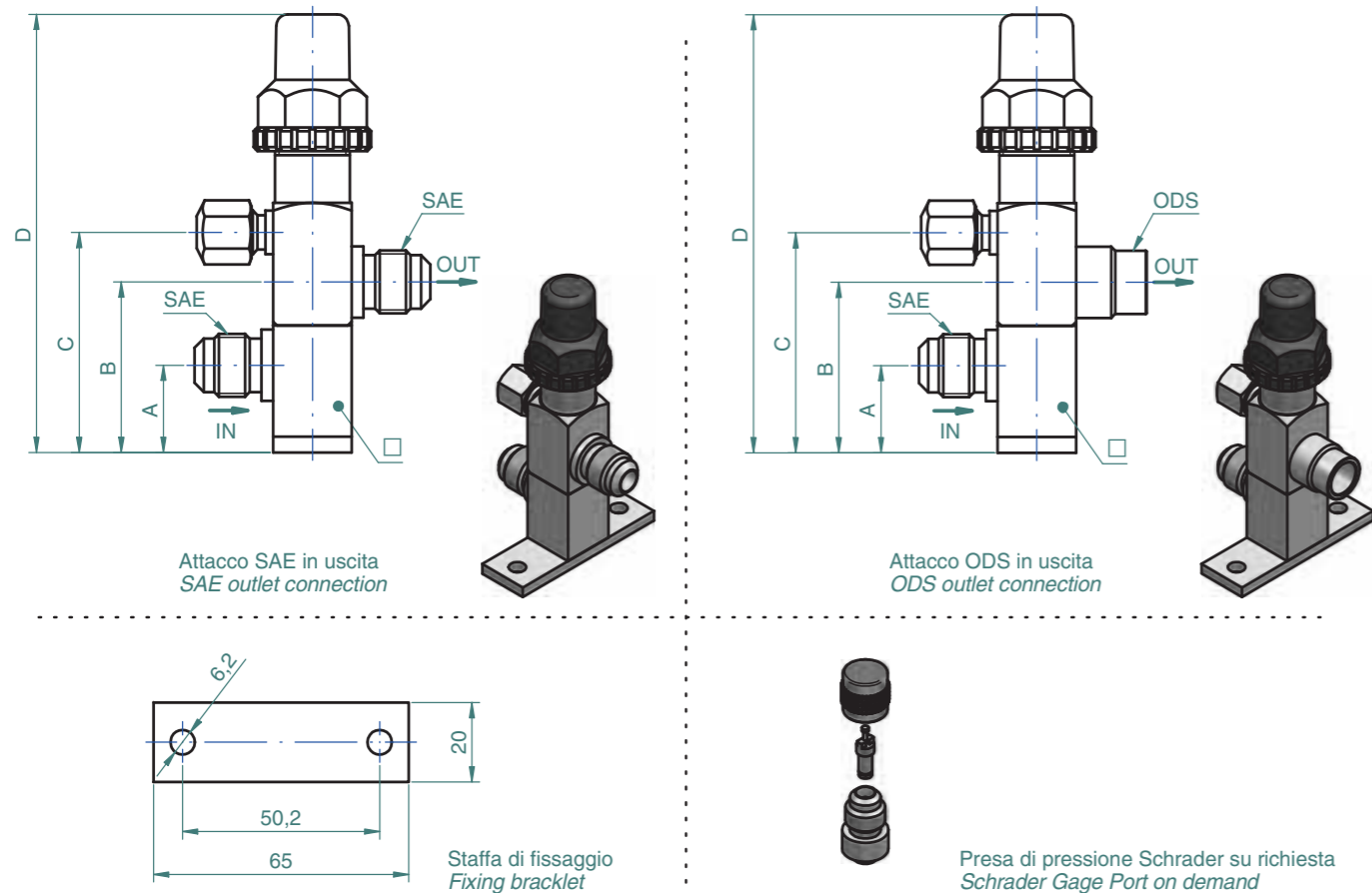

□	Attacco IN	Attacco OUT		A	B	C	D	
	SAE	SAE	ODS					
mm			mm inch.	mm	mm	mm	mm	
□20	1/4"	1/4"	6 1/4"	22	43	55,5	111	
			8 3/8"	22	43	55,5	111	
			10 3/8"	22	43	55,5	111	
			12 1/2"	22	43	55,5	111	
			16 1/2"	22	43	55,5	111	
			18 5/8"	22	43	55,5	111	
	1/2"	3/8"	3/8"	22	43	55,5	111	
			10 3/8"	22	43	55,5	111	
			12 1/2"	22	43	55,5	111	
			16 1/2"	22	43	55,5	111	
			18 5/8"	22	43	55,5	111	
			22 5/8"	22	43	55,5	111	
			28 3/4"	22	43	55,5	111	

□	Attacco IN	Attacco OUT		A	B	C	D	
	SAE	SAE	ODS					
mm			mm inch.	mm	mm	mm	mm	
□22	1/2"	1/2"	12 1/2"	23	49	63	132	
			16 5/8"	23	49	63	132	
			18 3/4"	23	49	63	132	
			22 3/4"	23	49	63	132	
			22 7/8"	23	49	63	132	
	5/8"	5/8"	16 5/8"	23	49	63	132	
			18 3/4"	23	49	63	132	
			22 3/4"	23	49	63	132	
			22 7/8"	23	49	63	132	
□30	5/8"	5/8"	16 5/8"	30	62	79	151	
			18 3/4"	30	62	79	151	
			22 3/4"	30	62	79	151	
			22 7/8"	30	62	79	151	
	3/4"	3/4"	18 3/4"	30	62	79	151	
			22 3/4"	30	62	79	151	
			22 7/8"	30	62	79	151	
			28 1 1/8"	30	62	79	151	

MASSIMA PRESSIONE DI LAVORO Maximum working pressure	PS 50 bar	PS 37 bar
TEMPERATURA AMMISSIBILE Permissible temperature	TS -10/+150 °C	TS -40/+150 °C
PRESSIONE DI COLLAUDO Testing pressure	PT 71,5 bar	
FLUIDO REFRIGERANTE Refrigerant	GROUP 2 PED	
CATEGORIA PED Category PED	ARTICLE 3.3	
TRATTAMENTO SUPERFICIALE: RAMATURA, NICHELATURA O STAGNATURA. Surface treatment: copper, nickel or tin plated.		

RUBINETTI VERTICALI CON STAFFA, INGRESSO ODS, USCITA ROTALOCK - Vertical Valves with bracket, ODS inlet and Rotalock outlet

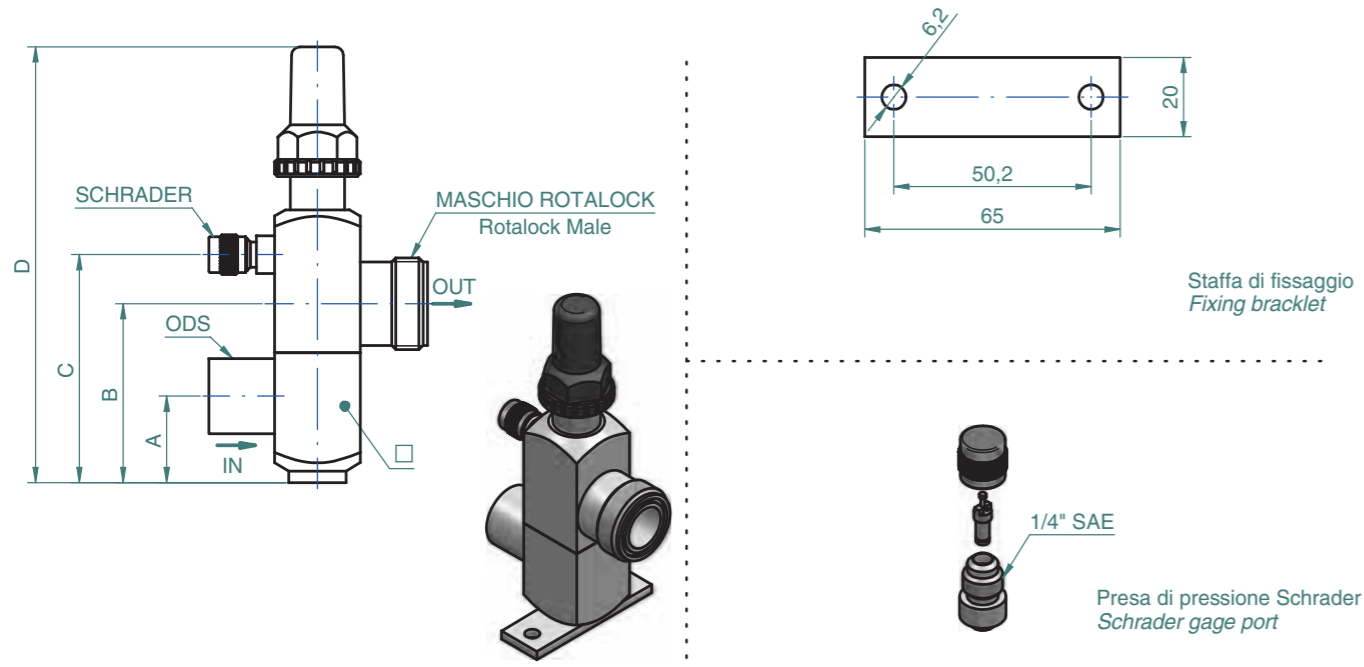

□	Attacco ODS ODS Connection		Maschio ROTALOCK Rotalock Male	A	B	C	D
	mm	inch.					
□30	16	5/8"	1 1/4" - 12 UNF	30	62	79	151
	18		1 1/4" - 12 UNF	30	62	79	151
		3/4"	1 1/4" - 12 UNF	30	62	79	151
	22		1 1/4" - 12 UNF	30	62	79	151
		7/8"	1 1/4" - 12 UNF	30	62	79	151
		1 1/8"	1 1/4" - 12 UNF	30	62	79	151
□35	28		1 3/4" - 12 UN	36	82	105,5	208
		1 1/8"	1 3/4" - 12 UN	36	82	105,5	208
	35	1 3/8"	1 3/4" - 12 UN	36	82	105,5	208
		1 5/8"	1 3/4" - 12 UN	36	82	105,5	208
	42		1 3/4" - 12 UN	36	82	105,5	208

MASSIMA PRESSIONE DI LAVORO Maximum working pressure	PS 50 bar	PS 37 bar
TEMPERATURA AMMISSIBILE Permissible temperature	TS -10/+150 °C	TS -40/+150 °C
PRESSIONE DI COLLAUDO Testing pressure	PT 71,5 bar	
FLUIDO REFRIGERANTE Refrigerant	GROUP 2 PED	
CATEGORIA PED Category PED	ARTICLE 3.3	
TRATTAMENTO SUPERFICIALE: RAMATURA, NICHELATURA O STAGNATURA. Surface treatment: copper, nickel or tin plated.		

RUBINETTI VERTICALI CON BASE FILETTATA E ODS IN RAME - Threading Vertical Valves with copper ODS

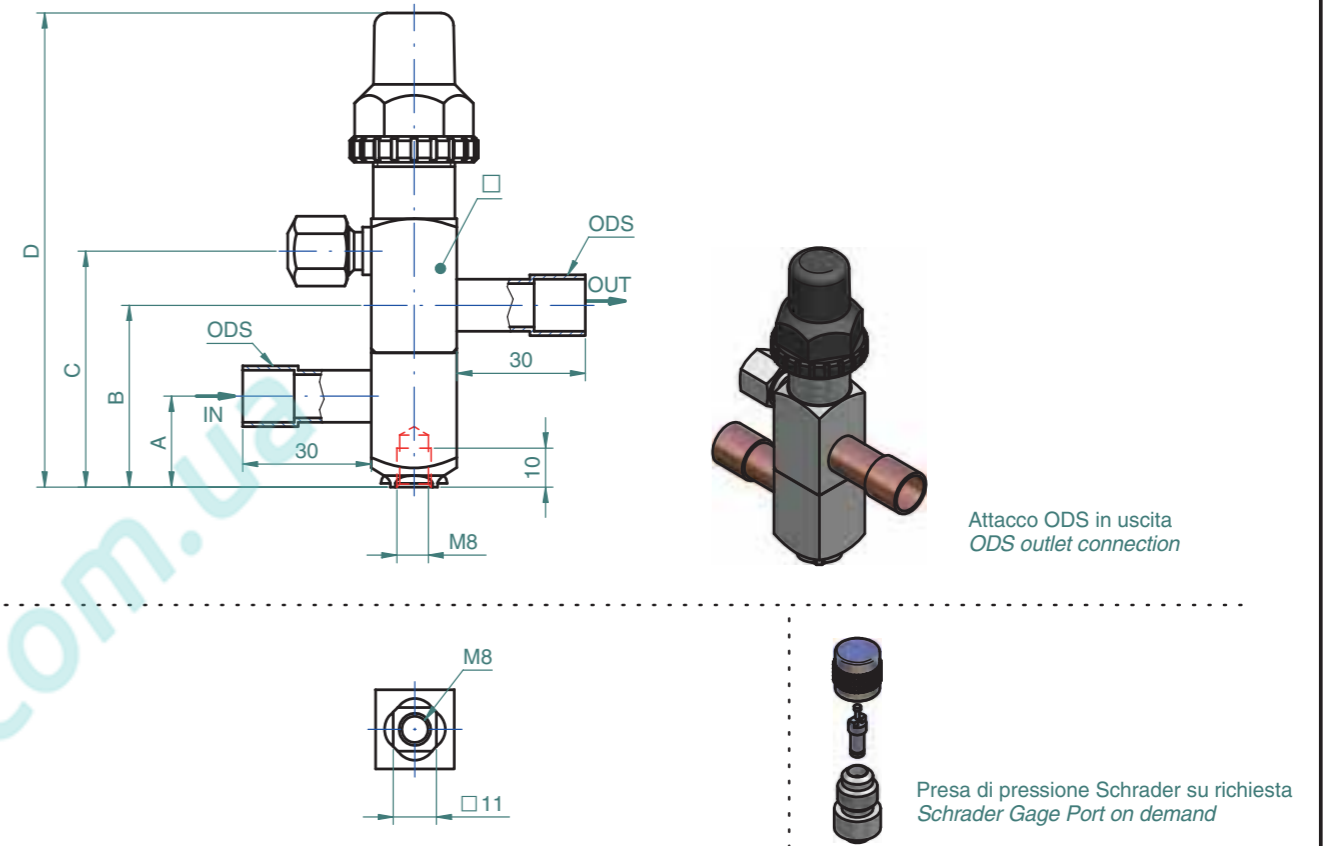

□	Attacco IN		Attacco OUT		A	B	C	D
	ODS		ODS					
mm	mm	inch.	mm	inch.	mm	mm	mm	mm
□20	6	1/4"	6		21	42	54,5	110
				1/4"	21	42	54,5	110
	8 - 10	3/8"	8		21	42	54,5	110
				3/8"	21	42	54,5	110
			10		21	42	54,5	110
			12		21	42	54,5	110
	12	1/2"		1/2"	21	42	54,5	110
			10		21	42	54,5	110
			12		21	42	54,5	110
				1/2"	21	42	54,5	110

MASSIMA PRESSIONE DI LAVORO Maximum working pressure	PS 50 bar	PS 37 bar
TEMPERATURA AMMISSIBILE Permissible temperature	TS -10/+150 °C	TS -40/+150 °C
PRESSIONE DI COLLAUDO Testing pressure	PT 71,5 bar	
FLUIDO REFRIGERANTE Refrigerant	GROUP 2 PED	
CATEGORIA PED Category PED	ARTICLE 3.3	
TRATTAMENTO SUPERFICIALE: RAMATURA, NICHELATURA O STAGNATURA. Surface treatment: copper, nickel or tin plated.		

RUBINETTI VERTICALI CON BASE FILETTATA, INGRESSO ODS, USCITA ODS O SAE -
Threading Vertical Valves, ODS inlet and ODS or SAE outlet

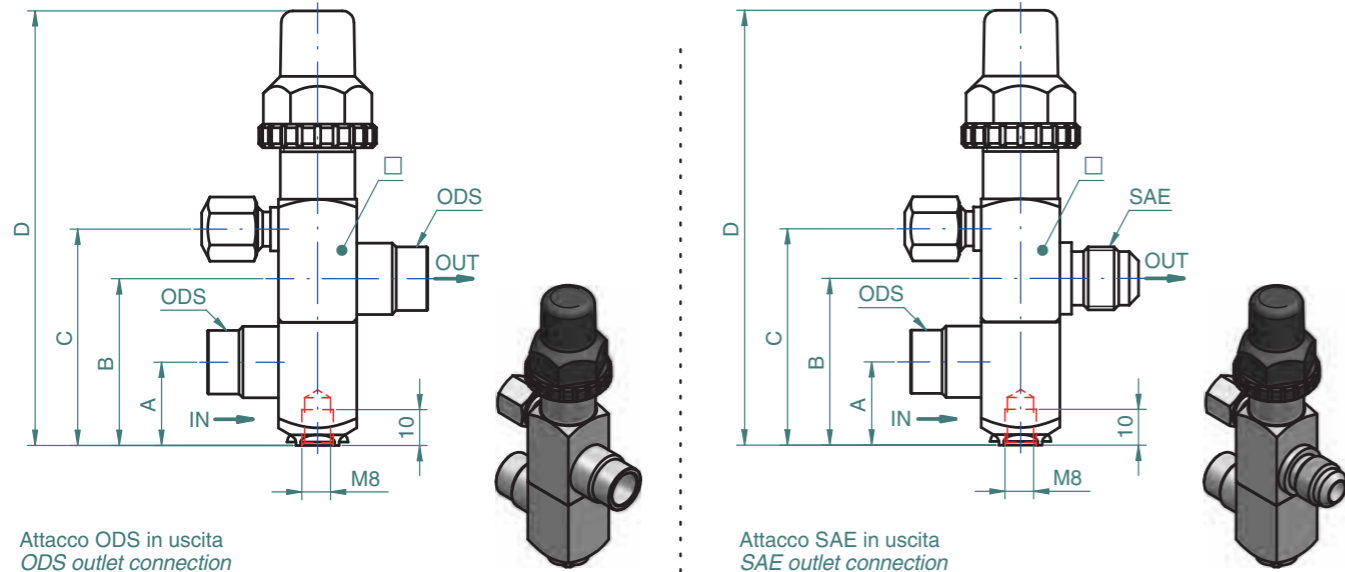

Attacco ODS in uscita
ODS outlet connection

Attacco SAE in uscita
SAE outlet connection

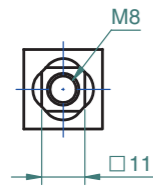

Presca di pressione Schrader su richiesta
Schrader Gage Port on demand

□	Attacco IN		Attacco OUT			A	B	C	D
	ODS		ODS	SAE					
mm	mm	inch.	mm	inch.		mm	mm	mm	mm
□20	6	1/4"		1/4"		21	42	54,5	110
			6			21	42	54,5	110
				1/4"		21	42	54,5	110
			8			21	42	54,5	110
				3/8"		21	42	54,5	110
					3/8"	21	42	54,5	110
	8 - 10	3/8"			1/2"	21	42	54,5	110
			10			21	42	54,5	110
				1/2"		21	42	54,5	110
					5/8"	21	42	54,5	110
			16			21	42	54,5	110
				5/8"		21	42	54,5	110
	12	1/2"			3/8"	21	42	54,5	110
			10			21	42	54,5	110
				1/2"		21	42	54,5	110
					1/2"	21	42	54,5	110
			12			21	42	54,5	110
				1/2"		21	42	54,5	110
		5/8"	21	42	54,5	110			
	5/8"		21	42	54,5	110			
		3/4"	21	42	54,5	110			

MASSIMA PRESSIONE DI LAVORO Maximum working pressure	PS 50 bar	PS 37 bar
TEMPERATURA AMMISSIBILE Permissible temperature	TS -10/+150 °C	TS -40/+150 °C
PRESSIONE DI COLLAUDO Testing pressure	PT 71,5 bar	
FLUIDO REFRIGERANTE Refrigerant	GROUP 2 PED	
CATEGORIA PED Category PED	ARTICLE 3.3	
TRATTAMENTO SUPERFICIALE: RAMATURA, NICHELATURA O STAGNATURA. Surface treatment: copper, nickel or tin plated.		

RUBINETTI VERTICALI CON BASE FILETTATA, INGRESSO SAE, USCITA SAE O ODS -
Threading Vertical Valves, SAE inlet and SAE or ODS outlet

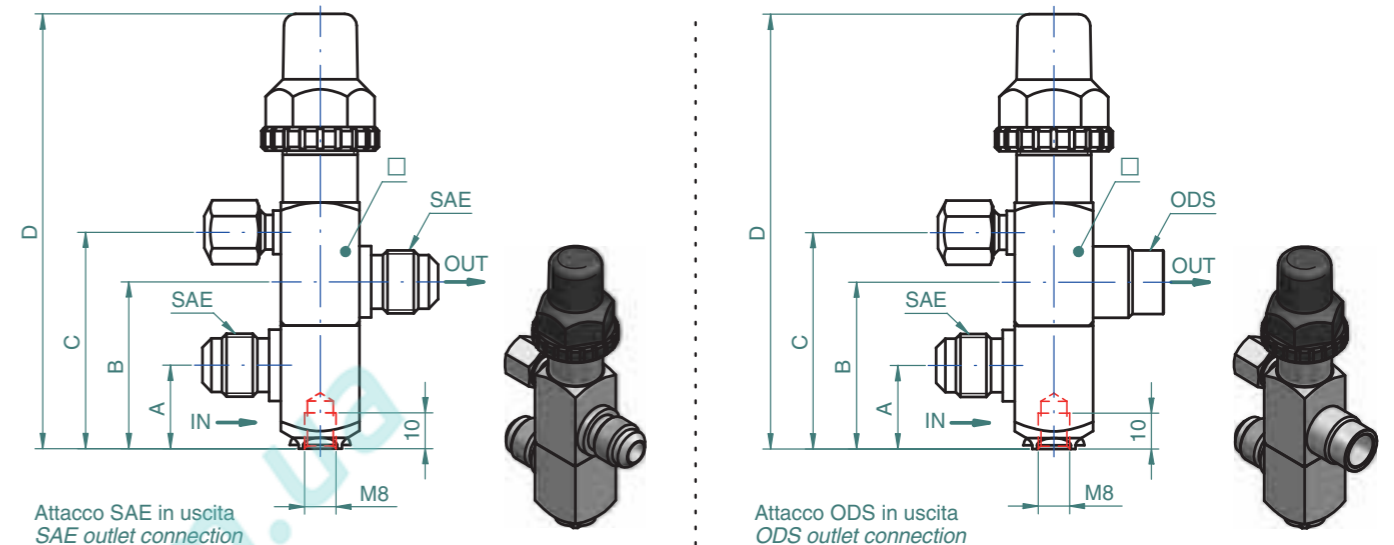

Attacco SAE in uscita
SAE outlet connection

Attacco ODS in uscita
ODS outlet connection

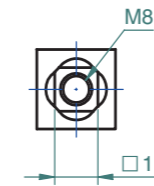

Presca di pressione Schrader su richiesta
Schrader Gage Port on demand

□	Attacco IN	Attacco OUT		A	B	C	D	
	SAE	SAE	ODS					
mm		mm	inch.	mm	mm	mm	mm	
□20	1/4"		1/4"		21	42	54,5	110
		6			21	42	54,5	110
			1/4"		21	42	54,5	110
		8			21	42	54,5	110
			3/8"		21	42	54,5	110
				3/8"	21	42	54,5	110
	3/8"			1/2"	21	42	54,5	110
		10			21	42	54,5	110
			1/2"		21	42	54,5	110
				1/2"	21	42	54,5	110
		12			21	42	54,5	110
			1/2"		21	42	54,5	110
	1/2"			3/8"	21	42	54,5	110
		10			21	42	54,5	110
			1/2"		21	42	54,5	110
				1/2"	21	42	54,5	110
		12			21	42	54,5	110
			1/2"		21	42	54,5	110
		5/8"	21	42	54,5	110		
	5/8"		21	42	54,5	110		
		3/4"	21	42	54,5	110		

MASSIMA PRESSIONE DI LAVORO Maximum working pressure	PS 50 bar	PS 37 bar
TEMPERATURA AMMISSIBILE Permissible temperature	TS -10/+150 °C	TS -40/+150 °C
PRESSIONE DI COLLAUDO Testing pressure	PT 71,5 bar	
FLUIDO REFRIGERANTE Refrigerant	GROUP 2 PED	
CATEGORIA PED Category PED	ARTICLE 3.3	
TRATTAMENTO SUPERFICIALE: RAMATURA, NICHELATURA O STAGNATURA. Surface treatment: copper, nickel or tin plated.		

RUBINETTI VERTICALI CON ATTACCO ROTALOCK IN INGRESSO - Vertical Valves with Rotalock inlet

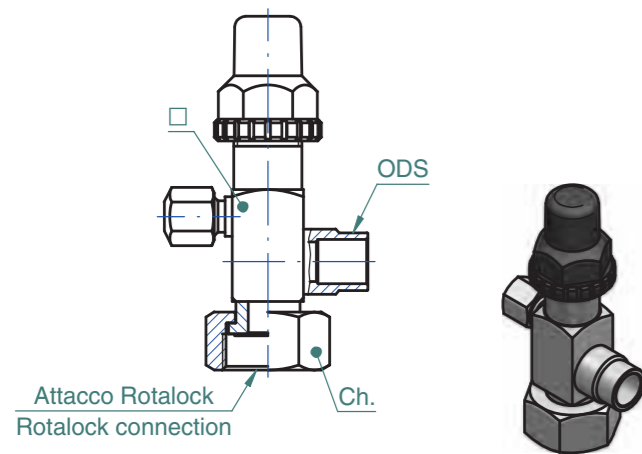

Rubineti verticali con attacco ODS
Vertical valves with ODS connection

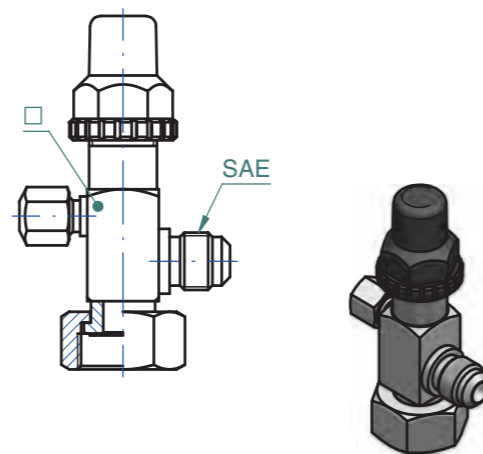

Rubineti verticali con attacchi SAE
Vertical valves with SAE connection

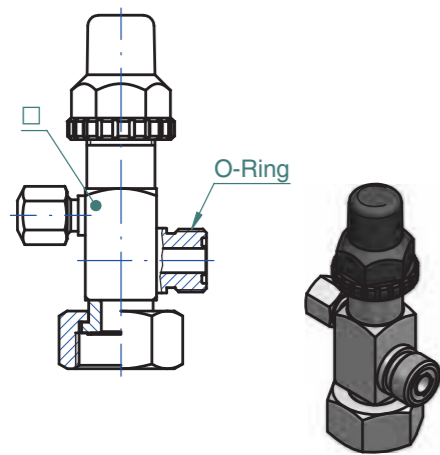

Rubineti verticali con attacco O-Ring
Vertical valves with O-Ring connection

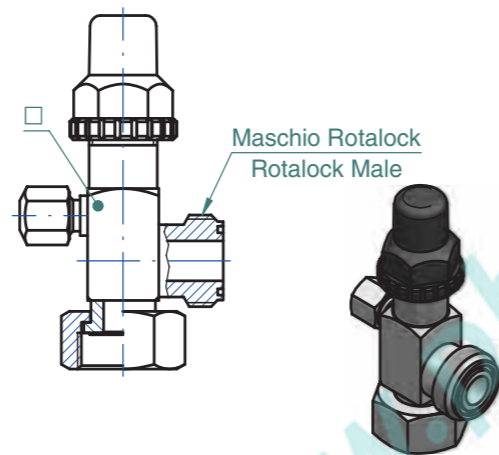

Rubineti verticali con maschio Rotalock
Vertical valves with male connection

□	Attacco Rotalock Rotalock connection	Attacco in uscita Outlet connection				Ch. mm
		ODS		SAE	O-Ring	
mm		mm	inch.			
□20	1" -14 UNS		3/8"			30
		10		1/4"	1/4"	
		12		3/8"	3/8"	
			1/2"	1/2"	1 1/4" -12 UNF	
□22	1" -14 UNS	16	5/8"	5/8"	5/8"	30
		18		3/4"		
			3/4"			
	1 1/4" -12 UNF	16	5/8"	5/8"	5/8"	36
		18		3/4"		

□	Attacco Rotalock Rotalock connection	Attacco in uscita Outlet connection				Ch. mm
		ODS		SAE	O-Ring	
mm		mm	inch.			
□30	1 1/4" -12 UNF	18		5/8" 3/4"	3/4"	1 1/4" -12 UNF
			3/4"			
		22				
□35	1 3/4" - 12 UN	28		/	/	1 1/4" - 12 UNF 1 3/4" - 12 UN
			1 1/8"			
		35				
			1 3/8"			
□45	2 1/4" -12 UN	42		/	/	1 3/4" - 12 UN 2 1/4" - 12 UN
			1 5/8"			
		35				
			1 3/8"			
		42				
		54	2 1/8"			

MASSIMA PRESSIONE DI LAVORO Maximum working pressure	PS 50 bar	PS 37 bar
TEMPERATURA AMMISSIBILE Permissible temperature	TS -10/+150 °C	TS -40/+150 °C
PRESSIONE DI COLLAUDO Testing pressure	PT 71,5 bar	
FLUIDO REFRIGERANTE Refrigerant	GROUP 2 PED	
CATEGORIA PED Category PED	ARTICLE 3.3	
TRATTAMENTO SUPERFICIALE: RAMATURA, NICHELATURA O STAGNATURA. Surface treatment: copper, nickel or tin plated.		

**RUBINETTI ESAGONALI CON ODS IN RAME -
Hexagonal Valves with copper ODS**

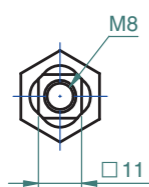
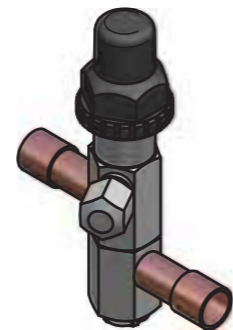
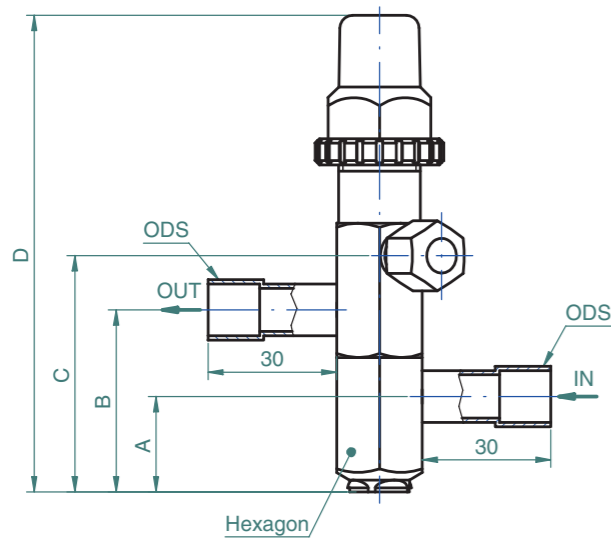

Presa di pressione Schrader su richiesta
Schrader Gage Port on demand

Hexagon	Attacco IN		Attacco OUT		A	B	C	D
	ODS		ODS					
mm	mm	inch.	mm	inch.	mm	mm	mm	mm
Hex. 20	6	1/4"			21	42	54,5	110
			6	1/4"	21	42	54,5	110
			8	3/8"	21	42	54,5	110
	8 - 10	3/8"	8		21	42	54,5	110
			10	3/8"	21	42	54,5	110
			12		21	42	54,5	110
			12	1/2"	21	42	54,5	110
	12	1/2"	10	3/8"	21	42	54,5	110
			12		21	42	54,5	110
			12	1/2"	21	42	54,5	110

MASSIMA PRESSIONE DI LAVORO Maximum working pressure	PS 50 bar	PS 37 bar
TEMPERATURA AMMISSIBILE Permissible temperature	TS -10/+150 °C	TS -40/+150 °C
PRESSIONE DI COLLAUDO Testing pressure	PT 71,5 bar	
FLUIDO REFRIGERANTE Refrigerant	GROUP 2 PED	
CATEGORIA PED Category PED	ARTICLE 3.3	
TRATTAMENTO SUPERFICIALE: RAMATURA, NICHELATURA O STAGNATURA. Surface treatment: copper, nickel or tin plated.		

**RUBINETTI DI SCAMBIO A TRE VIE
Three-Way Dual Shut-Off Valves**

□ mm	INLET Type A NPT	INLET Type B Rotalock	OUTLETS Type A - B NPT	C mm	D mm	E mm	F mm
□20	1/4" NPT	1"-14 UNS	1/4" NPT	48	12	44	121
	3/8" NPT	1"-14 UNS	3/8" NPT	48	12	44	121
□22	1/2" NPT	1 1/4"-12 UNF	3/8" NPT	55	14	50	144
	1/2" NPT	1 1/4"-12 UNF	1/2" NPT	55	14	50	144
□30	3/4" NPT	1 1/4"-12 UNF	3/4" NPT	80	18	73	179
□35	1" NPT	1 3/4"-12 UN	1" NPT	110	22	96	247
□45	1 1/4" NPT	2 1/4"-12 UN	1 1/4" NPT	110	28	95	260

Type A

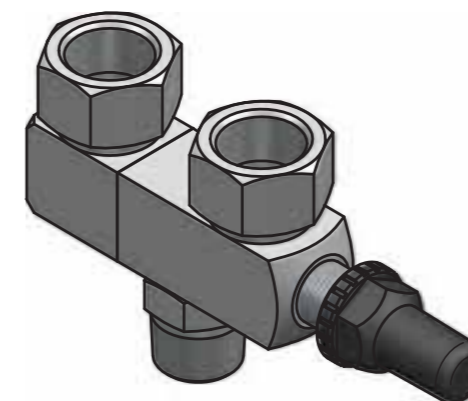
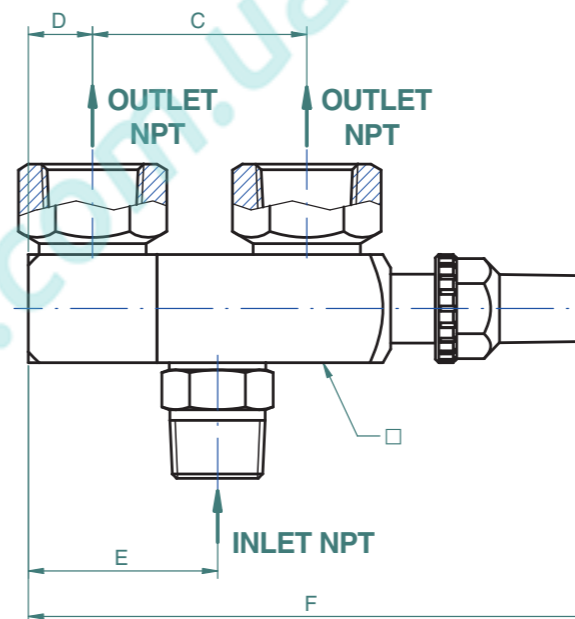

Type B

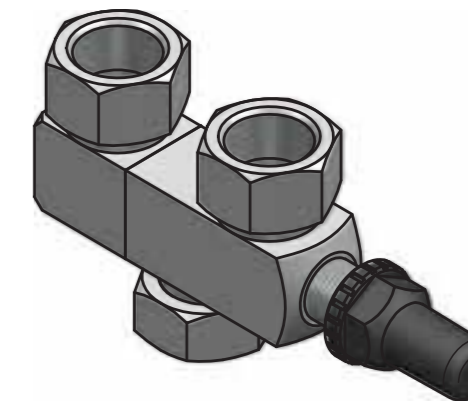
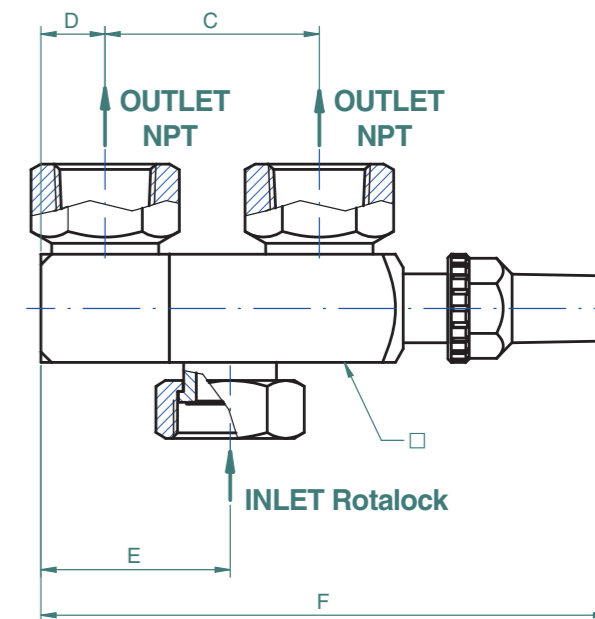

MASSIMA PRESSIONE DI LAVORO Maximum working pressure	PS 60 bar
PRESSIONE DI COLLAUDO Testing pressure	PT 86 bar
TEMPERATURA AMMISSIBILE Permissible temperature	TS -30/+150 °C
FLUIDO REFRIGERANTE Refrigerant	GROUP 2 PED
CATEGORIA PED Category PED	ARTICLE 3.3
TRATTAMENTO SUPERFICIALE: STAGNATURA Surface treatment: Tin plated	
A RICHIESTA PER AMMONIACA (NH ₃ - R717) On request for Ammonia (NH ₃ - R717)	

RUBINETTI DI SCAMBIO A TRE VIE CON ADATTATORI
Three-Way Dual Shut-Off Valves with Adaptors

□ mm	INLET Type A NPT	INLET Type B Rotalock	OUTLETS Type A - B NPT	C mm	D mm	E mm	F mm
□20	1/4" NPT	1"-14 UNS	1/4" NPT	48	12	44	121
	3/8" NPT	1"-14 UNS	3/8" NPT	48	12	44	121
□22	1/2" NPT	1 1/4"-12 UNF	3/8" NPT	55	14	50	144
	1/2" NPT	1 1/4"-12 UNF	1/2" NPT	55	14	50	144
□30	3/4" NPT	1 1/4"-12 UNF	3/4" NPT	80	18	73	179
□35	1" NPT	1 3/4"-12 UN	1" NPT	110	22	96	247
□45	1 1/4" NPT	2 1/4"-12 UN	1 1/4" NPT	110	28	95	260

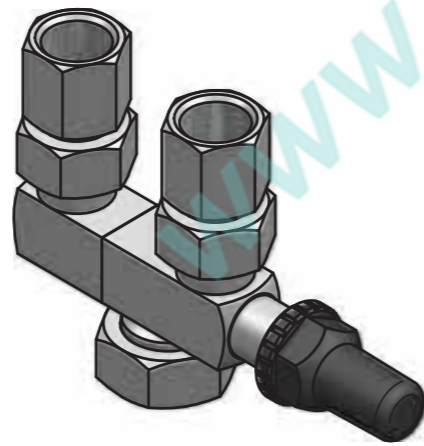
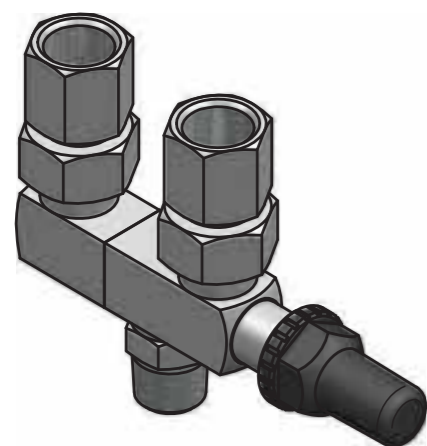
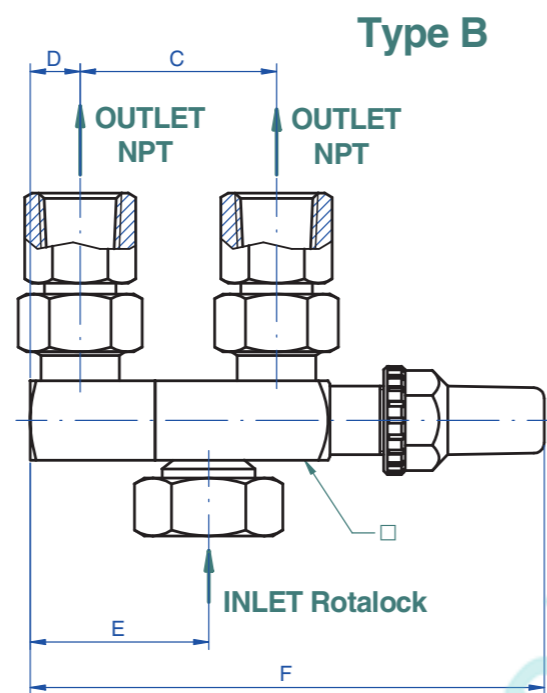
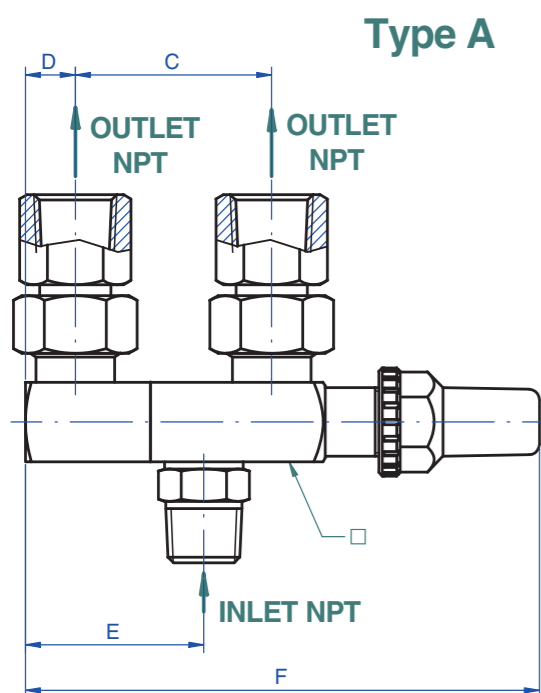

MASSIMA PRESSIONE DI LAVORO Maximum working pressure	PS 60 bar
PRESSIONE DI COLLAUDO Testing pressure	PT 86 bar
TEMPERATURA AMMISSIBILE Permissible temperature	TS -30/+150 °C
FLUIDO REFRIGERANTE Refrigerant	GROUP 2 PED
CATEGORIA PED Category PED	ARTICLE 3.3
TRATTAMENTO SUPERFICIALE: STAGNATURA Surface treatment: Tin plated	
A RICHIESTA PER AMMONIACA (NH ₃ - R717) On request for Ammonia (NH ₃ - R717)	

RUBINETTI DI SCAMBIO A TRE VIE PER CO₂ (R744)
Three-Way Dual Shut-Off Valves for CO₂ (R744)

□ mm	INLET NPT	OUTLETS NPT	C mm	D mm	E mm	F mm
□20	1/4" NPT	1/4" NPT	48	12	44	121
	3/8" NPT	3/8" NPT	48	12	44	121
□22	1/2" NPT	3/8" NPT	55	14	50	144
	1/2" NPT	1/2" NPT	55	14	50	144
□30	3/4" NPT	3/4" NPT	80	18	73	179
□35	1" NPT	1" NPT	110	22	96	247
□45	1 1/4" NPT	1 1/4" NPT	110	28	95	260

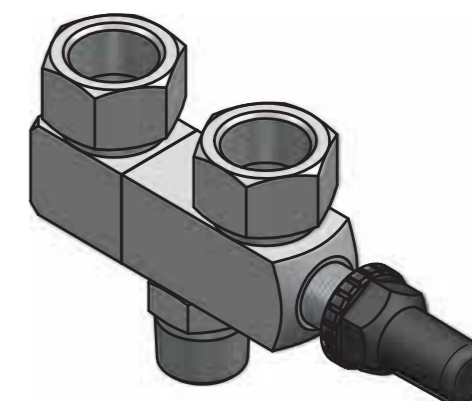
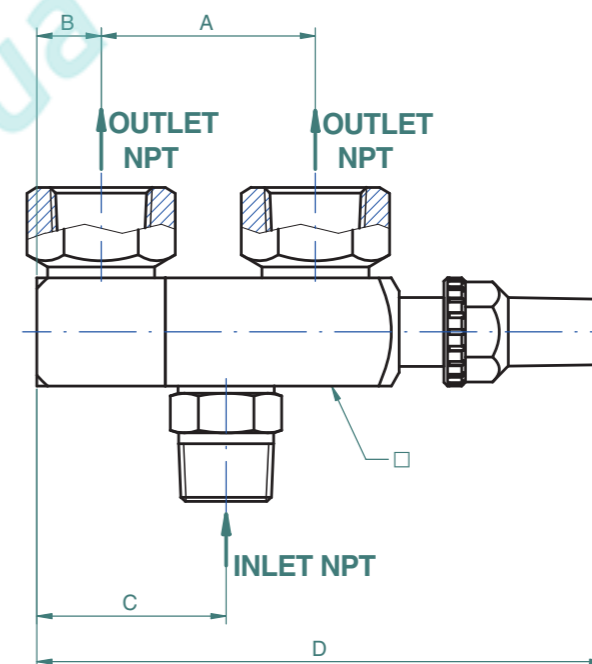

MASSIMA PRESSIONE DI LAVORO Maximum working pressure	PS 130 bar
PRESSIONE DI COLLAUDO Testing pressure	PT 186 bar
TEMPERATURA AMMISSIBILE Permissible temperature	TS -30/+150 °C
FLUIDO REFRIGERANTE Refrigerant	GROUP 2 PED
CATEGORIA PED Category PED	ARTICLE 3.3
TRATTAMENTO SUPERFICIALE: STAGNATURA Surface treatment: Tin plated	

VALVOLE DI SICUREZZA A SCARICO LIBERO - Safety valves free outlet

MATERIAL	CODE	Ø PASSAGGIO Flow diam. mm	IN	OUT GAS ISO 228	*KV Δ1bar m³/h	PRESSIONE TARATURA Setting pressure bar	SOVRAPRESSIONE Overpressure	* VALORI INDICATIVI Indicative values
OTTONE Brass	DL 7-14	7	1/4" NPT	/	0,60	1 ÷ 40	10%	
	DL 7-38	7	3/8" NPT	/	0,60	1 ÷ 40	10%	
	DL 10-38	10	3/8" NPT	/	0,70	1 ÷ 40	10%	
	DL 10-12	10	1/2" NPT	/	0,70	1 ÷ 40	10%	
OTTONE Brass 100 bar	DL 10-125	10	1/2" GAS	/	0,70	0,3 ÷ 100	10%	
	DL 10-344	10	3/4" GAS	/	0,70	0,3 ÷ 100	10%	
	DL 14-344	14	3/4" GAS	/	0,95	0,3 ÷ 100	10%	
	DL 14-14	14	1" GAS	/	0,95	0,3 ÷ 100	10%	
ACCIAIO INOX Stainless steel	DL 10-1245	10	1/2" GAS	/	0,70	0,3 ÷ 100	10%	
	DL 10-3445	10	3/4" GAS	/	0,75	0,3 ÷ 100	10%	
	DL 14-3445	14	3/4" GAS	/	0,75	0,3 ÷ 100	10%	
	DL 14-145	14	1" GAS	/	0,95	0,3 ÷ 100	10%	
OTTONE Brass 150 bar for CO2 (R744)	DL 10/345150	10	3/4" GAS	/	0,70	100 ÷ 150	10%	
	DL 10/14150	10	1" GAS	/	0,90	100 ÷ 150	10%	
	DL 14/1145150	14	1 1/4" GAS	/	1,15	100 ÷ 150	10%	

VALVOLE DI SICUREZZA A SCARICO CONVOGLIATO - Safety valves piped outlet

MATERIAL	CODE	Ø PASSAGGIO Flow diam. mm	IN	OUT GAS ISO 228	*KV Δ1bar m³/h	PRESSIONE TARATURA Setting pressure bar	SOVRAPRESSIONE Overpressure	CH mm	* VALORI INDICATIVI Indicative values
OTTONE Brass	DLD 7/C514	7	1/4" NPT	1/2"	0,60	0,3 ÷ 60	10%	22	
	DLD 7/C538	7	3/8" NPT	1/2"	0,60	0,3 ÷ 60	10%	22	
	DLD 10/C538	10	3/8" NPT	3/4"	0,70	0,3 ÷ 60	10%	25	
	DLD 10/C512	10	1/2" NPT	3/4"	0,70	0,3 ÷ 60	10%	25	
	DLD 14/S12	13,5	1/2" NPT	1"	0,90	0,3 ÷ 60	10%	30	
	DLD 14/S34	13,5	3/4" NPT	1"	0,90	0,3 ÷ 60	10%	30	
	DLD 14/S1	13,5	1" NPT	1"	0,95	0,3 ÷ 60	10%	35	
	DLD 20/S114	20	1 1/4" NPT	1 1/4"	1,10	0,3 ÷ 60	10%	45	
	DE 10/LS12	10	1/2" NPT	1"	0,70	0,3 ÷ 100	10%	30	
	DE 10/LS34	10	3/4" NPT	1"	0,70	0,3 ÷ 100	10%	30	
OTTONE Brass for CO2 (R744)	DE 10/1/150	10	1" NPT	1 1/4"	0,90	100 ÷ 150	10%	35	
	DE 10/114/150	10	1 1/4" NPT	1 1/4"	0,90	100 ÷ 150	10%	35	
	DE 14/LS34	14	3/4" NPT	1 1/4"	0,95	0,3 ÷ 100	10%	40	
	DE 14/LS1	14	1" NPT	1 1/4"	0,95	0,3 ÷ 100	10%	40	
	DE 14/LS114/150	14	1 1/4" NPT	1 1/2"	1,15	100 ÷ 150	10%	60	
	D 10G5A12	10	1/2" NPT	3/4"	0,70	0,3 ÷ 60	10%	25	
ACCIAIO INOX Stainless steel for NH3 (R717)	D 14/SA34	13,5	3/4" NPT	1"	0,90	0,3 ÷ 60	10%	30	
	D 14/SA1	13,5	1" NPT	1"	0,95	0,3 ÷ 60	10%	35	
	D 20/SA114	20	1 1/4" NPT	1 1/4"	1,10	0,3 ÷ 60	10%	45	

**VALVOLE DI SICUREZZA IN BY-PASS PER COMPRESSORI FRIGORIFERI
By-Pass protection Valve for refrigerator compressors**

NPTF	SEZIONE DI SCARICO Discharge section area mm²	PRESSIONE TARATURA Setting pressure bar	ES. mm	H mm
1/2"	40	20÷40	19	34
1"	226	20÷40	24	55
1 - 1/4"	452	20÷40	30	61
1 - 1/4"	615	20÷40	45	80

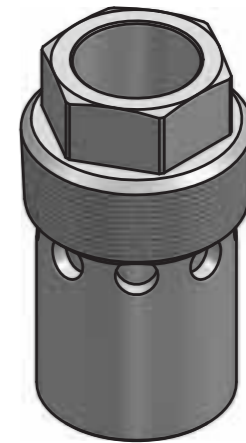
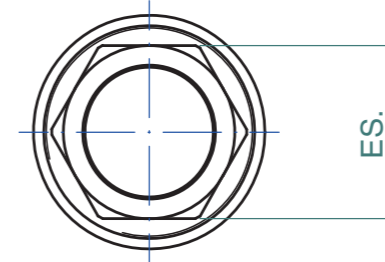
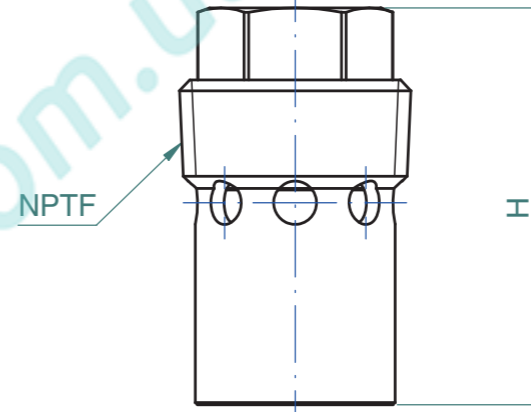

TRATTAMENTO SUPERFICIALE DI STAGNATURA
Surface treatment Tin plated
PER TUTTI I TIPI DI FREON E AMMONIACA (NH₃)
For all types of Freon and Ammonia (NH₃)

RUBINETTI IN GHISA SFEROIDALE
Ductile cast iron Valves

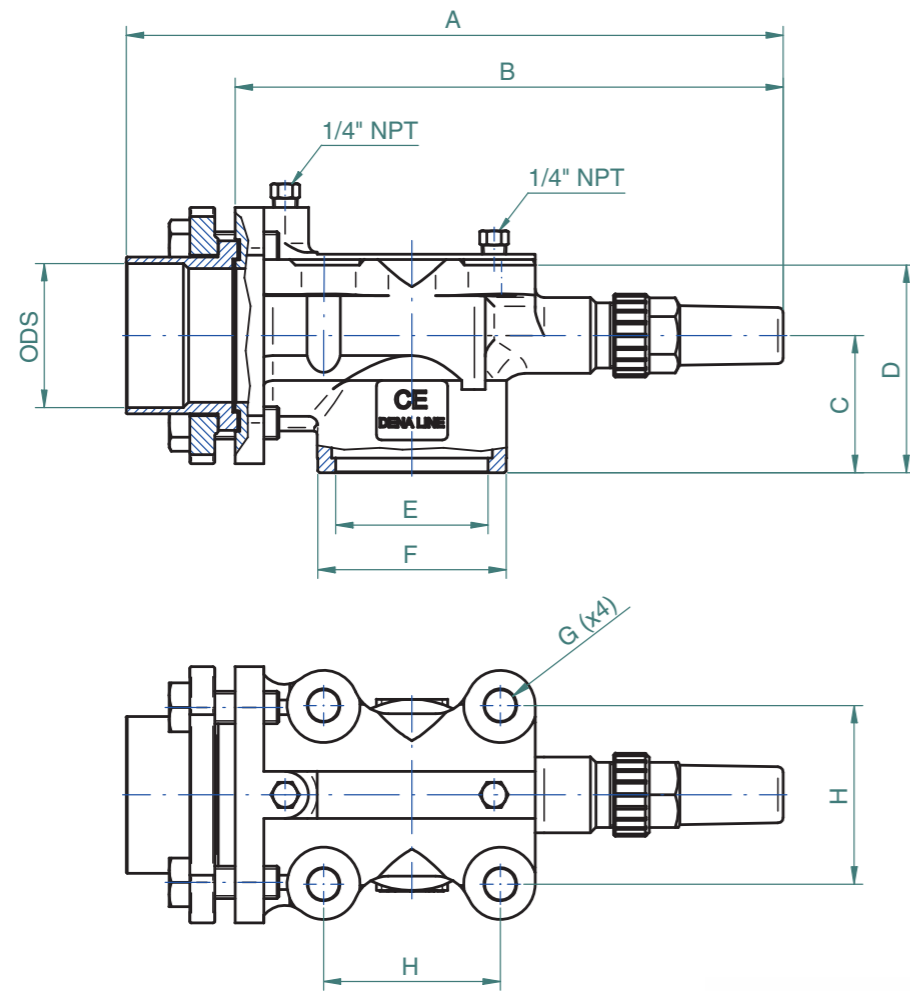

MASSIMA PRESSIONE DI LAVORO Maximum working pressure	PS 37 bar	PS 27 bar
TEMPERATURA AMMISSIBILE Permissible temperature	TS -10/+150 °C	TS -40/+150 °C
PRESSIONE DI COLLAUDO Testing pressure	PT 53 bar	
FLUIDO REFRIGERANTE Refrigerant	GROUP 2 PED	
TRATTAMENTO SUPERFICIALE A RICHIESTA Surface treatment on request		
CONFORME ALLA DIRETTIVA 97/23/CE (PED) According to directive 97/23/CE		

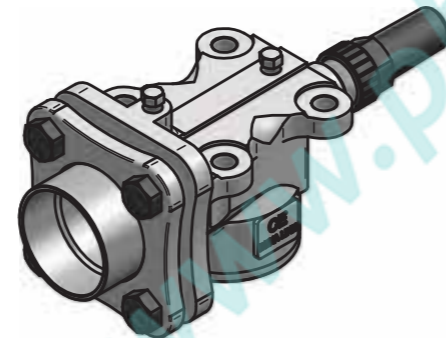

ODS inch/mm	NOMINAL SIZE	A mm	B mm	C mm	D mm	E mm	F mm	G mm	H mm	CATEGORY PED
1 3/8"	DN 40	238	205	46	68	Ø54	Ø70	Ø13,5	63,5	I
1 5/8"										
42										
2 1/8"	DN 50	280	230	62	86	Ø64,3	Ø81,5	Ø17,5	77,8	I
1 5/8"										
2 5/8"										
2 5/8"	DN 70	368	307	76	115	Ø85,3	Ø105,5	Ø17,5	99	I
3 1/8"										
80										
4 1/8"	DN 94	415	347	91	135	Ø110	Ø130,5	Ø20	122	I
125	DN 125	470	402,5	104	148	Ø140	Ø160	Ø22	142,2	II

RUBINETTI IN GHISA SFEROIDALE PER AMMONIACA (NH3 - R717)
Ductile cast iron Valves for ammonia (NH3 - R717)

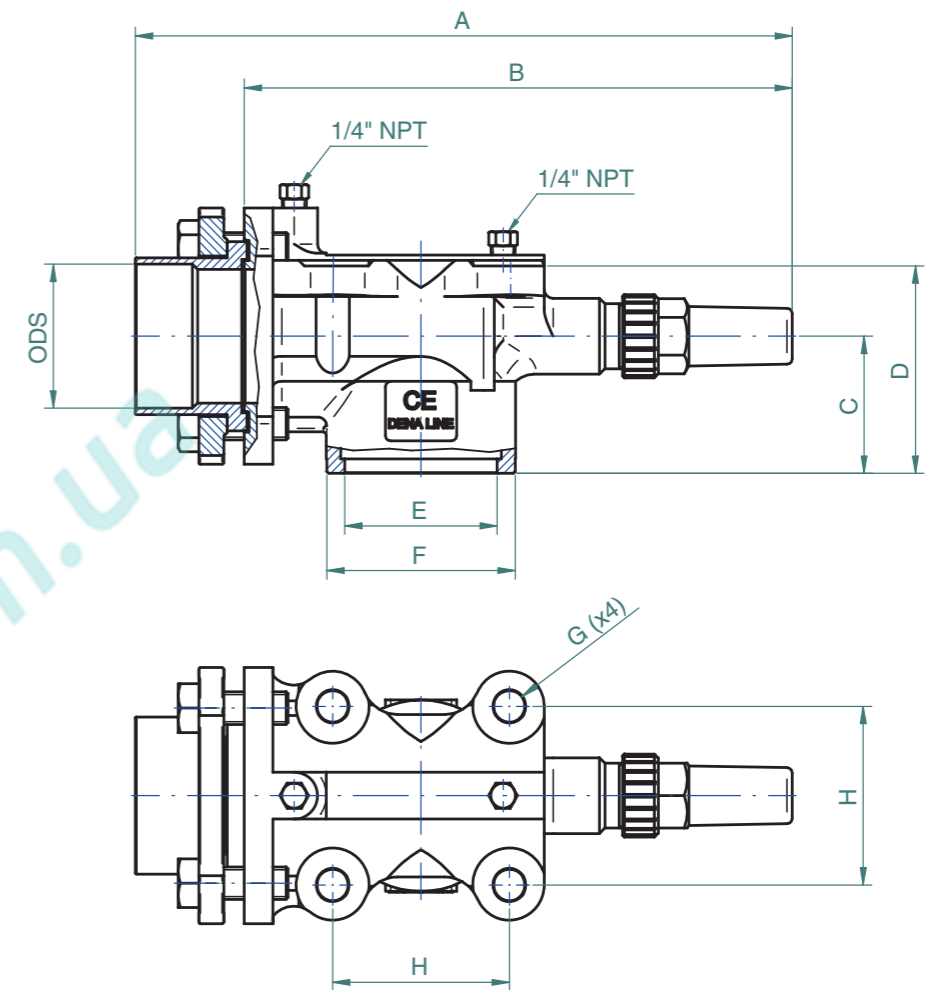

MASSIMA PRESSIONE DI LAVORO Maximum working pressure	PS 37 bar	PS 27 bar
TEMPERATURA AMMISSIBILE Permissible temperature	TS -10/+150 °C	TS -40/+150 °C
PRESSIONE DI COLLAUDO Testing pressure	PT 53 bar	
FLUIDO REFRIGERANTE Refrigerant	GROUP 1 PED	
TRATTAMENTO SUPERFICIALE A RICHIESTA Surface treatment on request		
CONFORME ALLA DIRETTIVA 97/23/CE (PED) According to directive 97/23/CE		

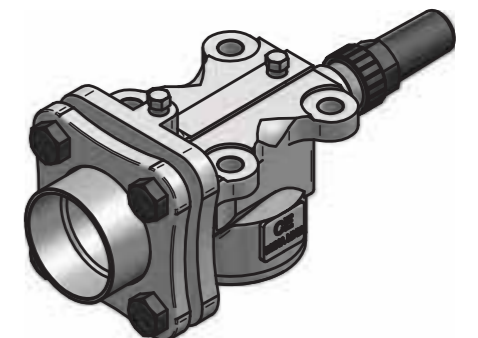

ODS inch/mm	NOMINAL SIZE	A mm	B mm	C mm	D mm	E mm	F mm	G mm	H mm	CATEGORY PED
1 3/8"	DN 40	238	205	46	68	Ø54	Ø70	Ø13,5	63,5	II
1 5/8"										
42										
2 1/8"	DN 50	280	230	62	86	Ø64,3	Ø81,5	Ø17,5	77,8	II
1 5/8"										
2 5/8"										
2 5/8"	DN 70	368	307	76	115	Ø85,3	Ø105,5	Ø17,5	99	II
3 1/8"										
80										
4 1/8"	DN 94	415	347	91	135	Ø110	Ø130,5	Ø20	122	II
125	DN 125	470	402,5	104	148	Ø140	Ø160	Ø22	142,2	III

RUBINETTI IN GHISA SFEROIDALE PER CO₂ (R744)
Ductile cast iron Valves for CO₂ (R744)

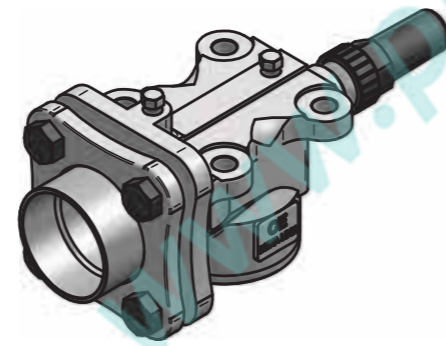
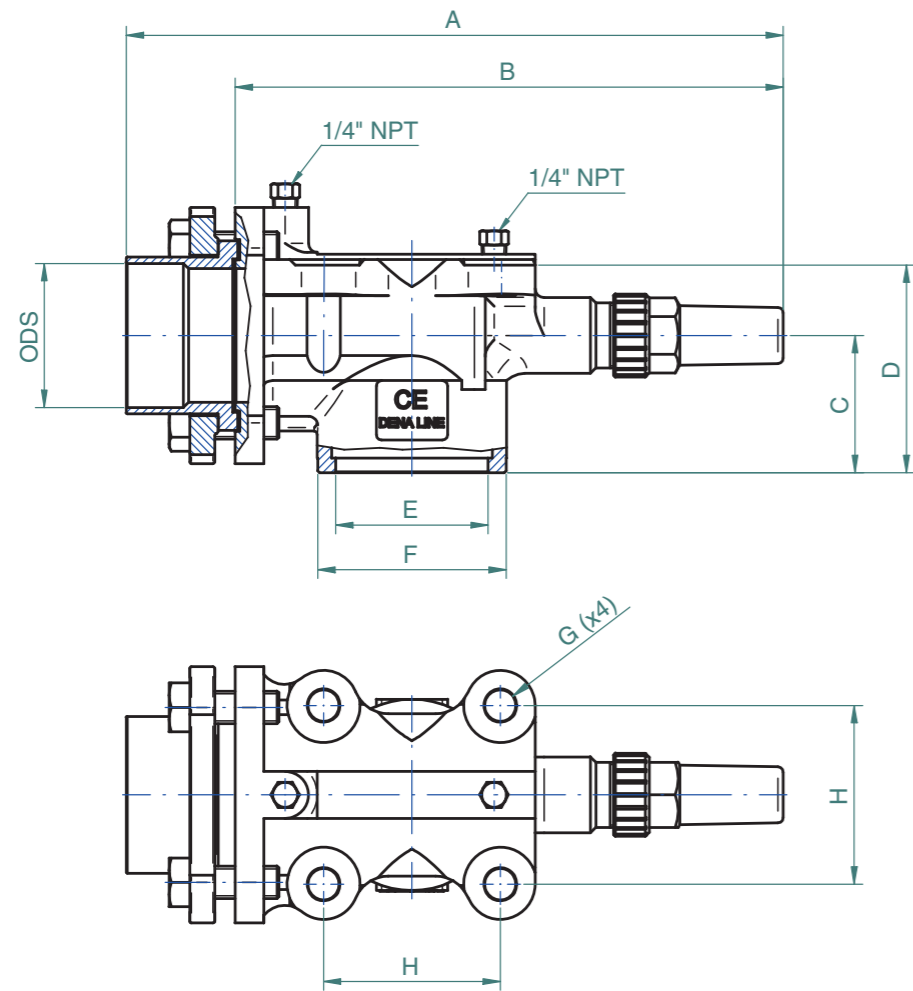

MASSIMA PRESSIONE DI LAVORO Maximum working pressure	PS 150 bar	PS 110 bar
TEMPERATURA AMMISSIBILE Permissible temperature	TS -10/+150 °C	TS -40/+150 °C
PRESSIONE DI COLLAUDO Testing pressure	PT 215 bar	
FLUIDO REFRIGERANTE Refrigerant	GROUP 2 PED	
TRATTAMENTO SUPERFICIALE A RICHIESTA Surface treatment on request		
CONFORME ALLA DIRETTIVA 97/23/CE (PED) According to directive 97/23/CE		

ODS inch/mm	NOMINAL SIZE	A mm	B mm	C mm	D mm	E mm	F mm	G mm	H mm	CATEGORY PED
1 3/8"	DN 40	238	205	46	68	Ø54	Ø70	Ø13,5	63,5	III
1 5/8"										
42										
2 1/8"	DN 50	280	230	62	86	Ø64,3	Ø81,5	Ø17,5	77,8	III
1 5/8"										
2 1/8"										
2 5/8"	DN 70	368	307	76	115	Ø85,3	Ø105,5	Ø17,5	99	III
2 5/8"										
3 1/8"										
80										

FLANGE OVALI PER RUBINETTI PER COMPRESSORI FRIGORIFERI
Oval Flanges for valves for refrigerator compressors

A mm	B mm	C mm	Ø1 mm	Ø2 mm	S mm
35	51,5	25,5	8,40	13,0	8,30
41,3	61,5	34,5	8,70	13,0	8,30
			8,70	14,8	8,30
			8,70	19,0	8,30
45,0	65,0	38,0	8,50	14,8	10,0
			10,5	21,0	10,0
			10,5	14,8	10,0
55,0	75,0	43	10,5	19,0	10,0
			11,0	27,0	11,0
			11,5	19,0	10,0
66,0	91,0	52,0	11,5	27,0	11,0
			12,5	34,0	11,0
			12,5	27,0	11,0
70	91,0	52,0	12,5	27,0	11,0

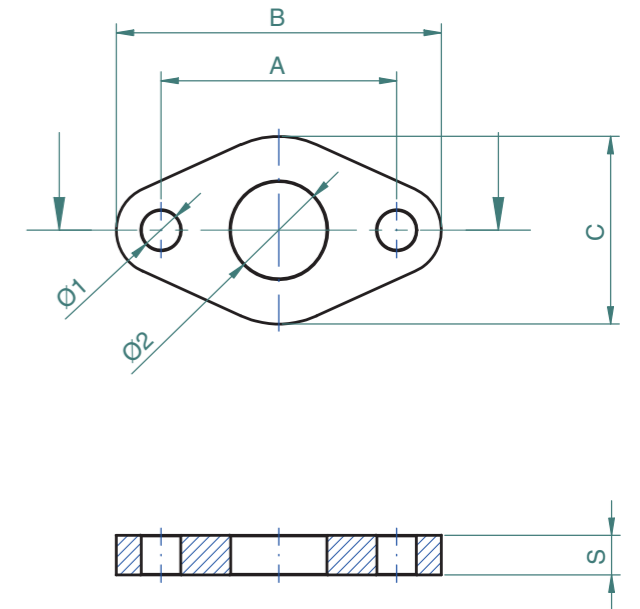

FLANGE IN GHISA
Cast iron flanges

A mm	B mm	C mm	D mm	Ø1 mm	Ø2 mm	Ø3 mm
54	80	14	16	13,5	40	56
54	80	14	16	13,5	47	56
78	110	14	16	18	61	80
78	110	14	16	18	74	90
97	142	14	16	21	89	108
97	142	14	16	21	99	108
122	166	16	18	21	116	134
122	166	16	18	21	119	134
122	166	16	18	22,5	116	134
142,2	190	26	28	22	143	165

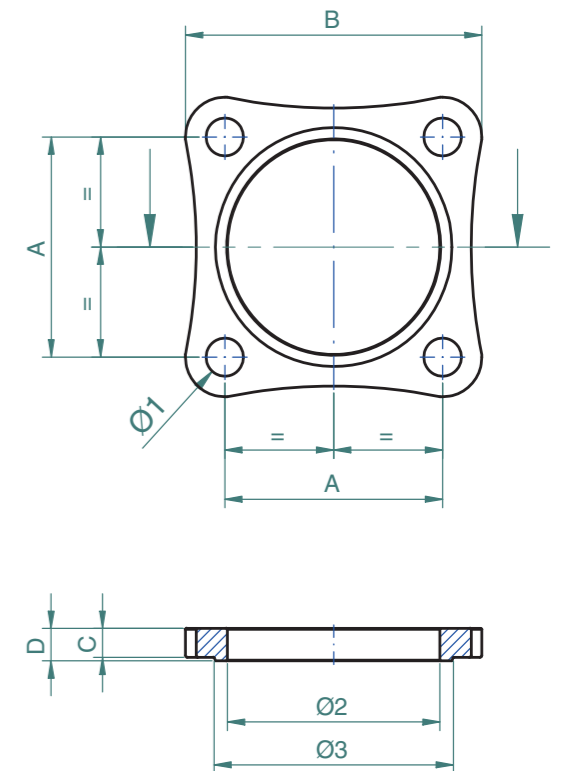

GUARNIZIONI PER RACCORDI, RUBINETTI ROTALOCK E VALVOLE IN GHISA
Gaskets for Rotalock connections, Valves, and Ductile Cast Iron Valves

(I) A richiesta, la DENA LINE è in grado di fornire le guarnizioni in PTFE sia a corredo delle valvole sia montate direttamente sui ricevitori di liquido previsti con attacco e valvola. Le misure standard degli anelli in PTFE sono indicate nelle tabelle seguenti:

(GB) Dena Line is able to supply PTFE gaskets either as outfit for valves or mounted on the liquid receivers with connection and valve. Standard dimensions are as follows:

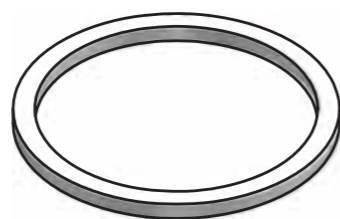
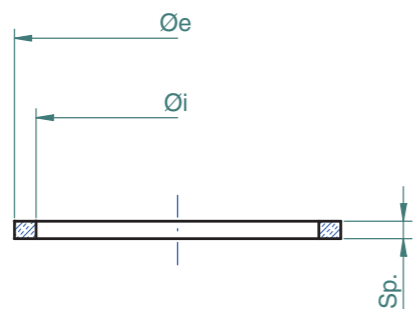

Per Valvole Rotalock
For Rotalock Valves

ROVALOCK	Øi mm	Øe mm	Sp. mm	Cod.
3/4" - 16 UNF	11,1	14,3	1,35	2570.001.0
1" - 14 UNS	15,7	19,1	1,35	2570.002.0
1 1/4" - 12 UNF	22	25,4	1,35	2570.003.0
1 1/2" - 16 UN	28,4	31,8	1,35	2570.005.0
1 3/4" - 12 UN	34,7	38,1	1,35	2570.004.0
2 1/4" - 12 UN	47,5	51	1,65	2570.006.0

Per Valvole in ghisa
For Ductile Cast Iron Valves

VALVOLE IN GHISA	Øi mm	Øe mm	Sp. mm	Cod.
DN 40	40	52	1,5	2570.009.0
DN 50	60	75	1,5	2570.011.0
DN 70	85	105	1,5	2570.012.0
DN 94	110,5	130	1,5	2570.013.0

RUBINETTI A SFERA
Ball valves

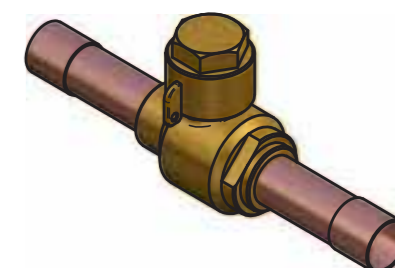
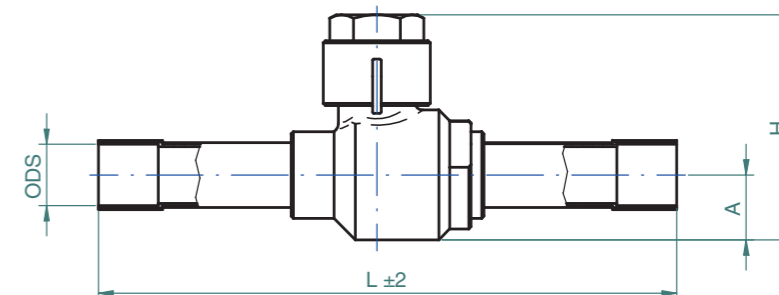
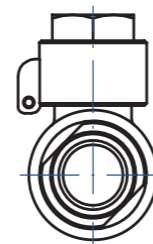

MODELLO	ODS		SFERA Ø	KV ΔP 1bar m³/h	L mm	H mm	A mm
	mm	inch.					
RSF006000	6		10	1,6	126	48	13
RSF000014		1/4"	10	1,6	126	48	13
RSF000038		3/8"	10	5,3	132	48	13
RSF010000	10		10	5,3	132	48	13
RSF012000	12		10	6,6	140	48	13
RSF000012		1/2"	10	6,6	140	48	13
RSF015000	15		16	13	146	60	19
RSF016058	16	5/8"	16	13	146	60	19
RSF018000	18		16	17	146	60	19
RSF000034		3/4"	16	17	146	60	19
RSF022078	22	7/8"	20	26	185	80	21
RSF028000	28		25	41	205	78	26
RSF000118		1 1/8"	25	41	205	78	26
RSF035138	35	1 3/8"	32	68	208	92	32
RSF000158		1 5/8"	38	100	240	112	39
RSF042000	42		38	100	240	112	39
RSF054218	54	2 1/8"	50	200	273	130	48
RSF064000	64		65	360	286	130	48
RSF000258		2 5/8"	65	360	378	130	60
RSF080318	80	3 1/8"	65	390	378	165	60
RSF089312	89	3 1/2"	80	510	420	200	76
RSF000358		3 5/8"	80	530	420	200	76
RSF105418	105	4 1/8"	83	560	420	200	76
RSF108414	108	4 1/4"	83	570	420	200	76

MASSIMA PRESSIONE DI LAVORO Maximum working pressure	PS 45 bar
TEMPERATURA AMMISSIBILE Permissible temperature	TS -30/+150 °C
PRESSIONE DI COLLAUDO Testing pressure	PT 65 bar
PER TUTTI I FLUIDI REFRIGERANTI COMPRESO CO2 SUBCRITICO (ESCLUSO NH3) For all kinds of refrigerant fluid included subcritical CO2 (NH3 excluded)	

RUBINETTI A SFERA PER CO₂ TRANSCRITICO (R744)
Ball valves for transcritical CO₂ (R744)

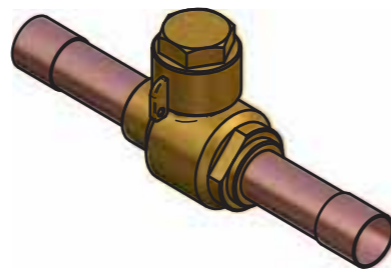
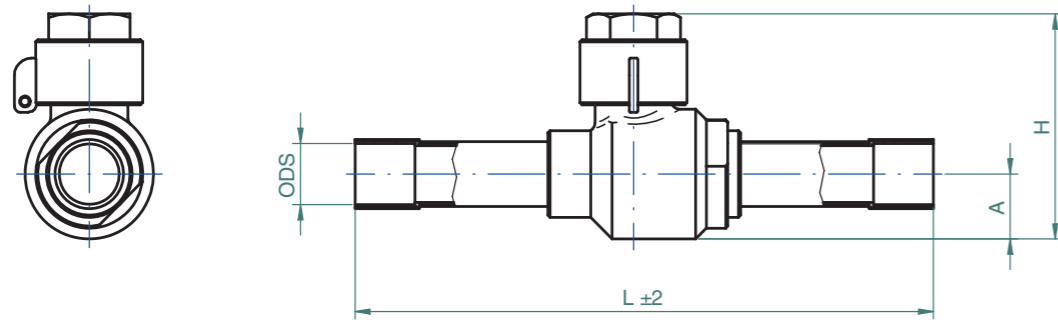

MODELLO	ODS		SFERA Ø	KV ΔP 1bar m³/h	L mm	H mm	A mm
	mm	inch.					
RSF006000TSC	6		10	1,6	126	48	13
RSF000014TSC		1/4"	10	1,6	126	48	13
RSF000038TSC		3/8"	10	5,3	132	48	13
RSF010000TSC	10		10	5,3	132	48	13
RSF012000TSC	12		10	6,6	140	48	13
RSF000012TSC		1/2"	10	6,6	140	48	13
RSF015000TSC	15		16	13	146	60	19
RSF016058TSC	16	5/8"	16	13	146	60	19
RSF018000TSC	18		16	17	146	60	19
RSF000034TSC		3/4"	16	17	146	60	19
RSF022078TSC	22	7/8"	20	26	185	80	21
RSF028000TSC	28		25	41	205	78	26
RSF000118TSC		1 1/8"	25	41	205	78	26
RSF035138TSC	35	1 3/8"	32	68	208	92	32
RSF000158TSC		1 5/8"	38	100	240	112	39
RSF042000TSC	42		38	100	240	112	39
RSF054218TSC	54	2 1/8"	50	200	273	130	48

MASSIMA PRESSIONE DI LAVORO Maximum working pressure	PS 120 bar
TEMPERATURA AMMISSIBILE Permissible temperature	TS -30/+150 °C
PRESSIONE DI COLLAUDO Testing pressure	PT 172 bar

RUBINETTI A SFERA PER AMMONIACA NH₃ (R717)
Ball valves for ammonia NH₃ (R717)

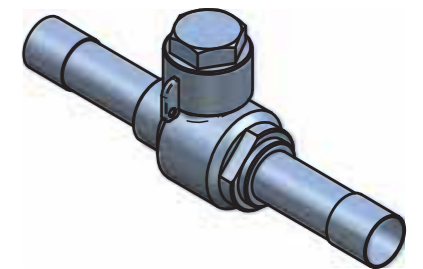
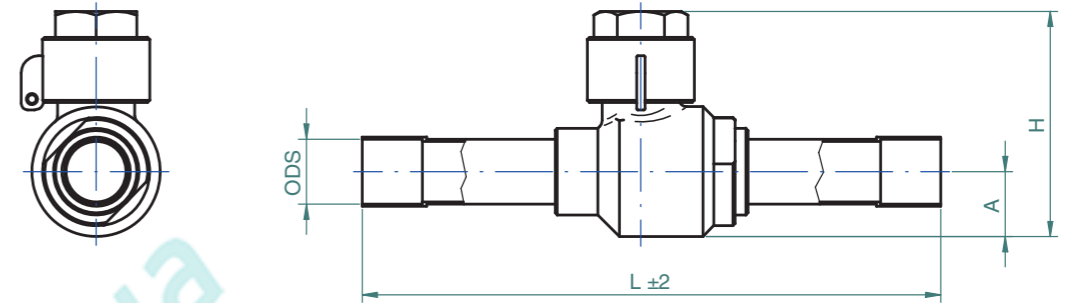

MODELLO	ODS		SFERA Ø	KV ΔP 1bar m³/h	L mm	H mm	A mm
	mm	inch.					
RSF015000AISI	15		19	20	202	80	29
RSF016058AISI	16	5/8"	19	24	202	80	29
RSF018000AISI	18		19	24	202	80	29
RSF000034AISI		3/4"	19	30	202	80	29
RSF022078AISI	22	7/8"	19	40	195	80	29
RSF028000AISI	28		32	67	210	105	42
RSF000118AISI		1 1/8"	32	77	210	105	42
RSF035138AISI	35	1 3/8"	32	77	230	105	42

MASSIMA PRESSIONE DI LAVORO Maximum working pressure	PS 45 bar
TEMPERATURA AMMISSIBILE Permissible temperature	TS -30/+150 °C
PRESSIONE DI COLLAUDO Testing pressure	PT 65 bar

INDICATORI DI PASSAGGIO E UMIDITA'
Liquid and moisture indicator

ODS SOLDER

CODE	ODS Inch.	CODE	ODS mm	L mm	L1 mm
DLSYFH-1/4	1/4"	DLSYFH-6	6	101	7,5÷8
DLSYFH-3/8	3/8"	DLSYFH-10	10	119	9
DLSYFH-1/2	1/2"	DLSYFH-12	12	146	12
DLSYFH-5/8	5/8"	DLSYFH-16	16	146	12
DLSYFH-3/4	3/4"	DLSYFH-18	18	173	14
DLSYFH-7/8	7/8"	DLSYFH-22	22	173	19

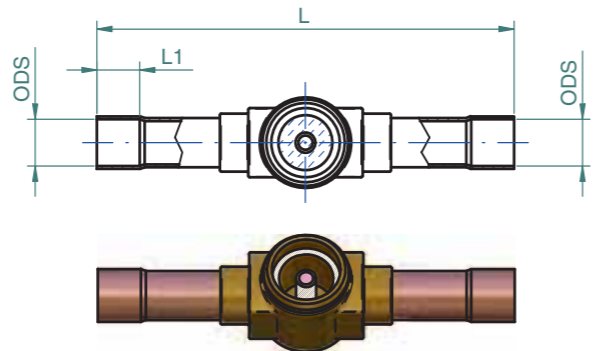

MALE FLARE

CODE	SAE Flare	UNF Thread	L mm
DLSYFL-1/4	1/4"	7/16" - 20	59,5
DLSYFL-3/8	3/8"	5/8" - 18	70
DLSYFL-1/2	1/2"	3/4" - 16	70
DLSYFL-5/8	5/8"	7/8" - 14	80

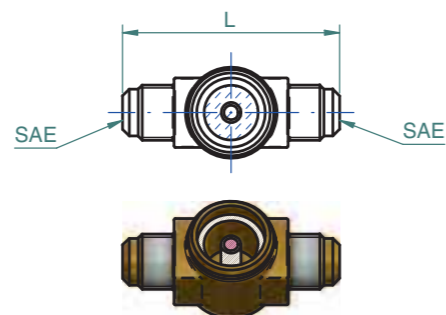

MALE & FEMALE FLARE

CODE	SAE Flare	UNF Thread	L mm
DLSYFL2-1/4	1/4"	7/16" - 20	60
DLSYFL2-3/8	3/8"	5/8" - 18	64

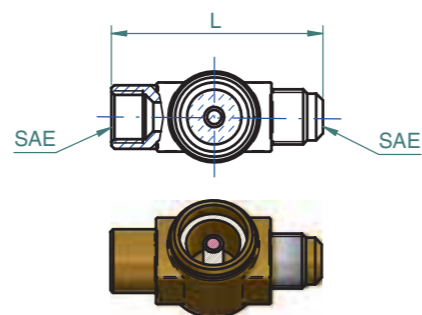

MALE & FEMALE O-RING

CODE	Thread	L mm
DLSYFL1-9/16	9/16" - 18 UNF	62,2
DLSYFL1-11/16	11/16" - 16 UN	62,2
DLSYFL1-5/8	7/8" - 14 UNF	67

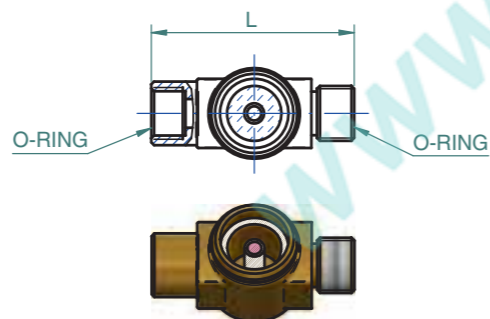

MOISTURE CONTENT PPM (at 40°C)			
REFRIGERANT	DRY (blue)	Transition (Chartreuse blue)	WET (pink)
R-12	< 5	5 ÷ 15	> 15
R-22	< 30	30 ÷ 110	> 110
R-134a	< 35	35 ÷ 120	> 120
R-401A	< 120	120 ÷ 420	> 420
R-401B	< 50	50 ÷ 175	> 175
R-404A	< 40	40 ÷ 140	> 140
R-410A	< 69	69 ÷ 240	> 240
R-502	< 10	10 ÷ 50	> 50
R-507	< 33	33 ÷ 115	> 115

SPECIFICATION

MASSIMA PRESSIONE DI LAVORO Maximum working pressure	PS 45 bar
TEMPERATURA AMMISSIBILE Permissible temperature	TS -40/+100 °C
FLUIDO REFRIGERANTE Refrigerant	GROUP 2 PED
CATEGORIA PED Category PED	ARTICLE 3.3

INDICATORI DI LIVELLO - Sight Glasses

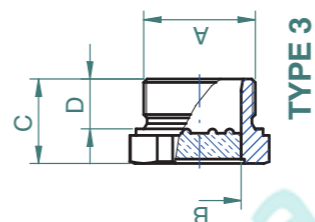
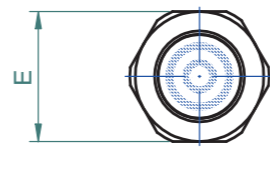

TYPE 3

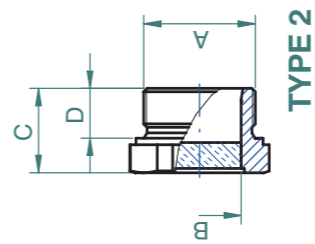
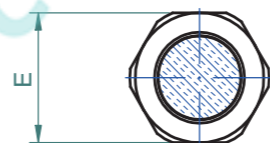

TYPE 2

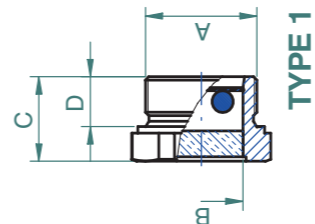
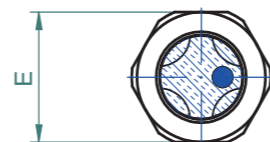

TYPE 1

CODE	CODE TYPE 1	CODE TYPE 2	CODE TYPE 3	A mm	B mm	C mm	D mm	E mm	Closed Torques Nm *	Note
DL 15	DLO 15	DLO 15A	DLO 15A	G 1/2"	Ø 15	16	8	27	70 ÷ 80	/
DL 18	DLO 18	DLO 18A	DLO 18A	M26x1,5	Ø 18	24	14	32	60 ÷ 70	With Aluminium gasket
DL 22	DLO 22	DLO 22A	DLO 22A	1 1/8" - 18 UNEF	Ø 22	17,6	11,2	35	40 ÷ 55	/
DL 28	DLO 28	DLO 28A	DLO 28A	M36x1,5	Ø 28	28	16	46	80 ÷ 90	With Aluminium gasket
DL 40	DLO 40	DLO 40A	DLO 40A	M52x2	Ø 40	39	23	60	120 ÷ 130	With Aluminium gasket

* Apply appropriate thread sealing.

DLRU18

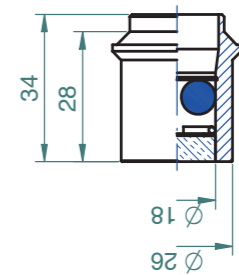

DLU18A

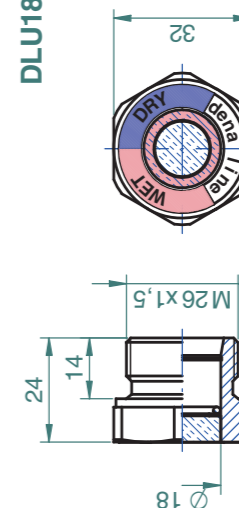

INDICATORI DI UMIDITA'
Moisture sight glasses

MOISTURE CONTENT PPM (at 40°C)			
REFRIGERANT	DRY (blue)	Transition (Chartreuse blue)	WET (pink)
R-12	< 5	5 ÷ 15	> 15
R-22	< 30	30 ÷ 110	> 110
R-134a	< 35	35 ÷ 120	> 120
R-401A	< 120	120 ÷ 420	> 420
R-401B	< 50	50 ÷ 175	> 175
R-404A	< 40	40 ÷ 140	> 140
R-410A	< 69	69 ÷ 240	> 240
R-502	< 10	10 ÷ 50	> 50
R-507	< 33	33 ÷ 115	> 115

MASSIMA PRESSIONE DI LAVORO Maximum working pressure	PS 80 bar	PS 60 bar
TEMPERATURA AMMISSIBILE Permissible temperature	TS -10/+120°C	TS -40/+120°C
PRESSIONE DI COLLAUDO Testing pressure	PT 115 bar	
FLUIDO REFRIGERANTE Refrigerant	GROUP 2 PED - R744(CO ₂) - R17 (NH ₃)	
TRATTAMENTO SUPERFICIALE DI STAGNATURA O ZINCO-NICHELATURA. Surface treatment Tin Plated or Zinc-nickel Plated.		

INDICATORI DI PASSAGGIO E UMIDITA' PER CO2 (R744)
Liquid and moisture indicator for CO2 (R744)

ODS SOLDER

CODE	ODS		L mm	S mm	Weight gr.
	mm	inch.			
DLMS06S06A	6		115	22	155
DLMS07S07A		1/4"	115	22	155
DLMS08S08A	8		115	22	160
DLMS09S09A		3/8"	115	22	160
DLMS10S10A	10		115	22	160
DLMS12S12A	12		120	22	180
DLMS13S13A		1/2"	120	22	180
DLMS16S16A	16	5/8"	125	22	200
DLMS18S18A	18		140	30	280
DLMS19S19A		3/4"	140	30	270
DLMS22S22A	22		150	30	360
DLMS23S23A		7/8"	150	30	360
DLMS28S28A	28		160	35	500
DLMS29S29A		1 1/8"	160	35	500

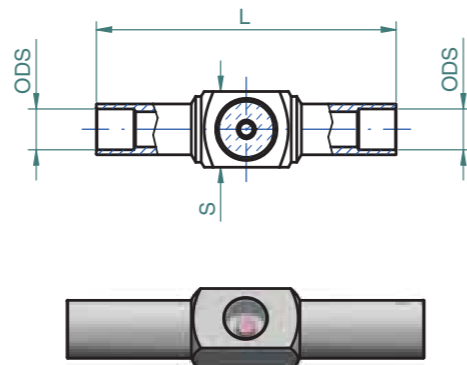

MALE FLARE

CODE	SAE Flare	UNF / UNS Thread	L mm	S mm	WEIGHT gr.
DLMM14M14A	1/4"	7/16" - 20	72	22	145
DLMM38M38A	3/8"	5/8" - 18	77	22	150
DLMM12M12A	1/2"	3/4" - 16	82	22	170
DLMM58M58A	5/8"	7/8" - 14	90	30	245
DLMM34M34A	3/4"	1 1/16" - 14	95	30	330

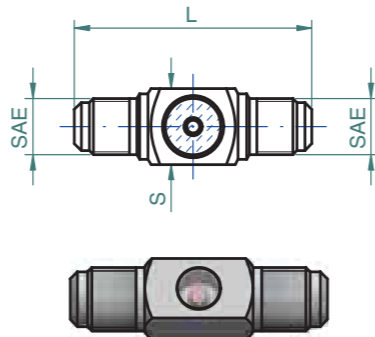

MALE & FEMALE FLARE

CODE	SAE Flare	UNF / UNS Thread	L mm	S mm	WEIGHT gr.
DLMM14F14A	1/4"	7/16" - 20	68	22	145
DLMM38F38A	3/8"	5/8" - 18	73	22	160
DLMM12F12A	1/2"	3/4" - 16	78	30	255
DLMM58F58A	5/8"	7/8" - 14	85	30	280
DLMM34F34A	3/4"	1 1/16" - 14	93	35	430

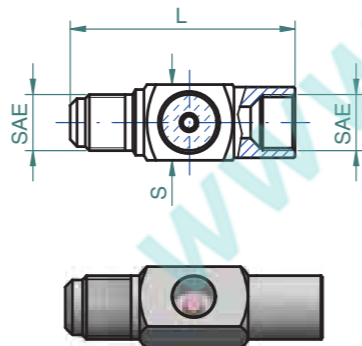

MOISTURE CONTENT PPM (at 40°C)			
REFRIGERANT	DRY (blue)	Transition (Chartreuse blue)	WET (pink)
R-12	< 5	5 ÷ 15	> 15
R-22	< 30	30 ÷ 110	> 110
R-134a	< 35	35 ÷ 120	> 120
R-401A	< 120	120 ÷ 420	> 420
R-401B	< 50	50 ÷ 175	> 175
R-404A	< 40	40 ÷ 140	> 140
R-410A	< 69	69 ÷ 240	> 240
R-502	< 10	10 ÷ 50	> 50
R-507	< 33	33 ÷ 115	> 115

SPECIFICATION

MASSIMA PRESSIONE DI LAVORO Maximum working pressure	PS 120 bar	PS 90 bar
TEMPERATURA AMMISSIBILE Permissible temperature	TS -10/+110 °C	TS -40/+110 °C
PRESSIONE DI COLLAUDO Testing pressure	PT 172 bar	
FLUIDO REFRIGERANTE Refrigerant	GROUP 2 PED	
CATEGORIA PED Category PED	ARTICLE 3.3	
TRATTAMENTO SUPERFICIALE: STAGNATURA. Surface treatment: tin plated.		

FLANGE PER RICEVITORI ≥ 100 LITRI E VALVOLE IN GHISA
Flanges for ≥ 100 liters receivers and ductile cast iron valves

TYPE	A mm	B mm	M mm	S mm	Ø1 mm	Ø2 mm
DN 40	□ 90	63,5	M12	20	71	50
DN 50	□ 110	77,8	M16	20	83	63,5
DN 70	□ 140	99	M16	20	107	78
DN 94	□ 170	122	M18	25	132	102

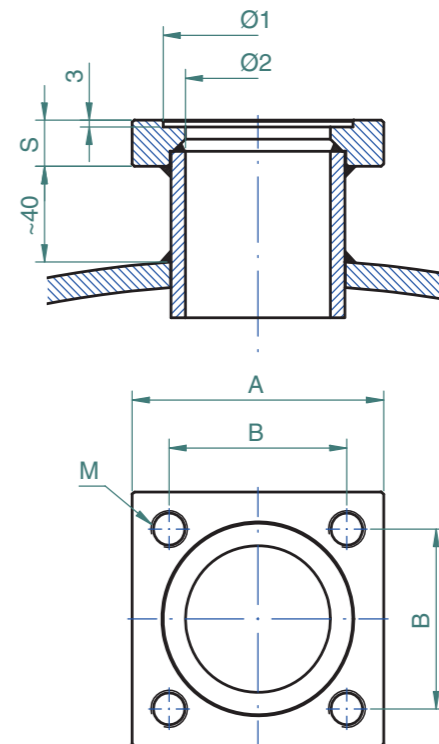

GUARNIZIONI PER FLANGE E VALVOLE IN GHISA
Gaskets for flanges and ductile cast iron valves

TYPE	Øe	Øi
DN 40	70	54
DN 50	82	64
DN 70	105	85
DN 94	130	110,5

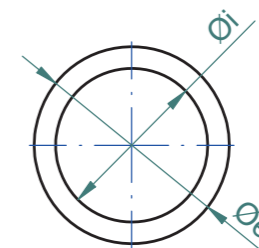

ATTACCHI A GOMITO ROTALOCK PER TUTTI I FLUIDI E CO₂
Elbow Rotalock connections for all fluids and CO₂

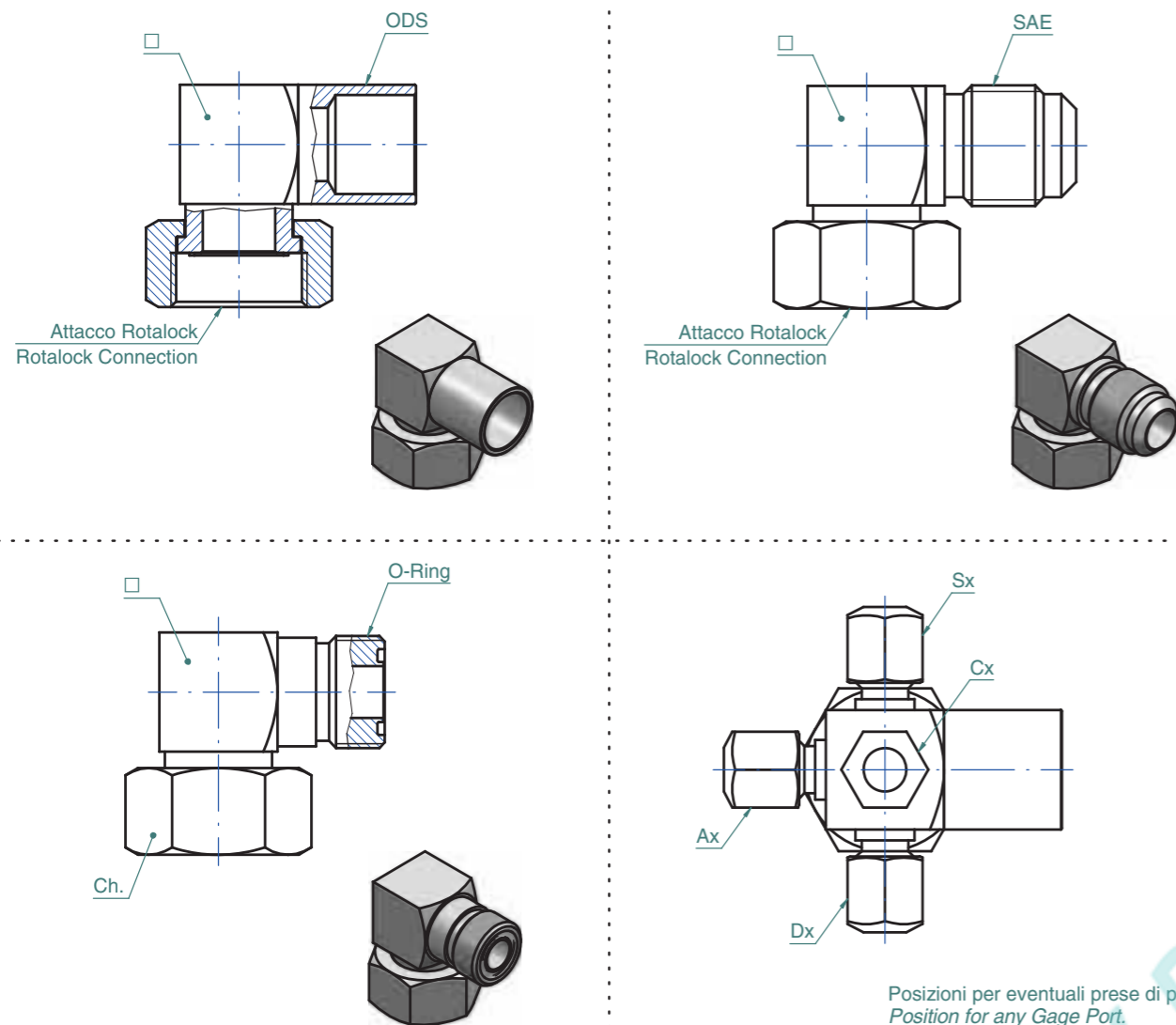

- COLLAUDO A RICHIESTA DEL CLIENTE
 Testing pressure on customer request

Corpo gomito Elbow	Attacco Rotalock Rotalock connection	Ch. mm	ODS mm	ODS inch.	SAE	O-RING
□ 20	3/4" - 16 UNF	24	6 - 8 - 10	1/4" - 3/8"	1/4" - 3/8" - 1/2"	1/4" - 3/8" - 1/2"
	1" - 14 UNS	30	10 - 12 - 16	3/8" - 1/2" - 5/8"	3/8" - 1/2" - 5/8"	3/8" - 1/2" - 5/8"
	1 1/4" - 12 UNF	36	16 - 18	5/8" - 3/4"	1/2" - 5/8" - 3/4"	1/2" - 5/8" - 3/4"
□ 22	1" - 14 UNS	30	16 - 18	5/8" - 3/4"	5/8" - 3/4"	5/8" - 3/4"
	1 1/4" - 12 UNF	36	18 - 22	3/4" - 7/8"	5/8" - 3/4"	5/8" - 3/4"
□ 30	1 1/4" - 12 UNF	36	18 - 22 - 28	3/4" - 7/8" - 1 1/8"	5/8" - 3/4"	/
	1 3/4" - 12 UNF	50	22 - 28	7/8" - 1 1/8"	5/8" - 3/4"	/
□ 35	1 1/2" - UN	46	28 - 35 - 42	1 1/8" - 1 3/8" - 1 5/8"	/	/
	1 3/4" - 12 UNF	50	28 - 35 - 42	1 1/8" - 1 3/8" - 1 5/8"	/	/
	2 1/4" - 12 UN	65	35 - 42	1 3/8" - 1 5/8"	/	/
□ 45	2 1/4" - 12 UN	65	35 - 42 - 54	1 3/8" - 1 5/8" - 2 1/8"	/	/

ATTACCHI DIRITTI ROTALOCK PER TUTTI I FLUIDI E CO₂
Straight Rotalock Connections for all fluids and CO₂

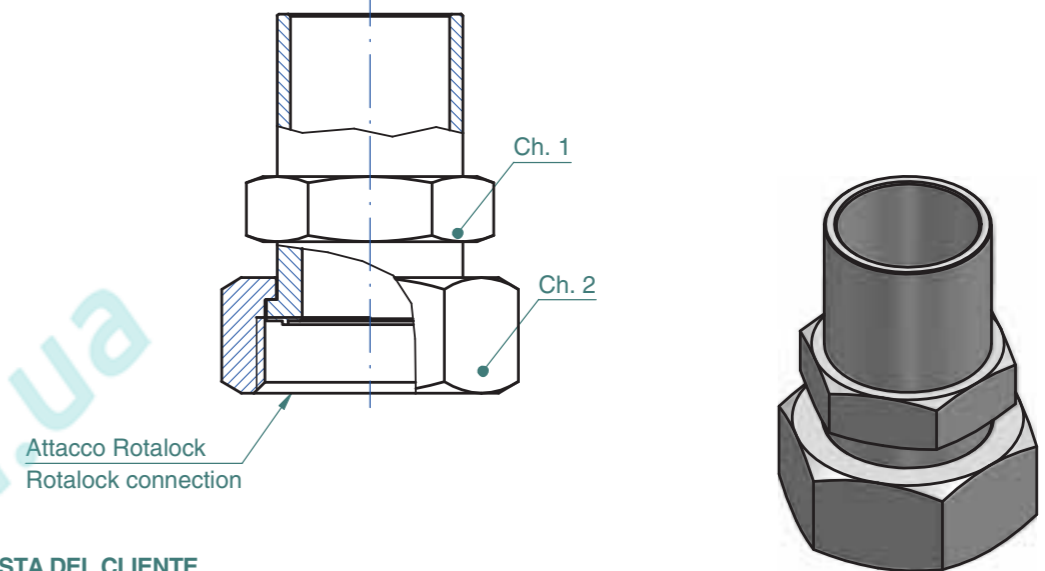

- COLLAUDO A RICHIESTA DEL CLIENTE
 Testing pressure on customer request

ROTALOCK	ODS mm	ODS inch.	Ch. 1 mm	Ch. 2 mm
3/4" - 16 UNF	6		20	24
	8	1/4"		
	10	3/8"		
	12			
1" - 14 UNS		1/2"	20 - 22	30
	10	3/8"		
	12			
	16	5/8"		
	18			
1 1/4" - 12 UNF		3/4"	27	36
	16	5/8"		
	18			
	22	7/8"		
	28			
		1 1/8"		
1 1/2" - 16 UN	28	1 1/8"	42	46
		1 3/8"		
	35	1 5/8"		
1 3/4" - 12 UN	42		42	50
	28	1 1/8"		
	35	1 3/8"		
		1 5/8"		
2 1/4" - 12 UNF	42		50	65
	35	1 3/8"		
		1 5/8"		
	42		50	65
	54	2 1/8"		

ATTACCHI ROTALOCK A SALDARE
Rotalock soldering connections

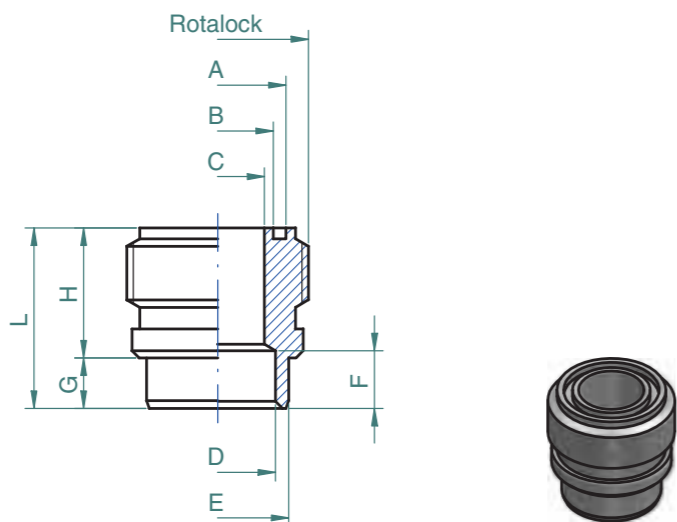

Rotalock	A mm	B mm	C mm	D mm	E mm	F mm	G mm	H mm	L mm	CODE
3/4" - 16 UNF	Ø14,3	Ø10,75	Ø9	Ø12,1	Ø16	10	5	15,5	20,5	4400.001.0
1" - 14 UNS	Ø19,1	Ø15,55	Ø13,1	Ø16,2	Ø20	16	7	18	25	4400.002.0
1 1/4" - 12 UNF	Ø25,4	Ø21,85	Ø19	Ø22,2	Ø25	6	5	23,5	28,5	4420.004.0
1 3/4" - 12 UN	Ø38,1	Ø34,55	Ø31	Ø35,3	Ø41	18	7	32	39	4401.003.0
2 1/4" - 12 UN	Ø51	Ø46,8	Ø40	Ø42,3	Ø50	20	8	38	46	4401.004.0

MASCHI ROTALOCK CON PRESA DI PRESSIONE
Rotalock Male with Schrader connection

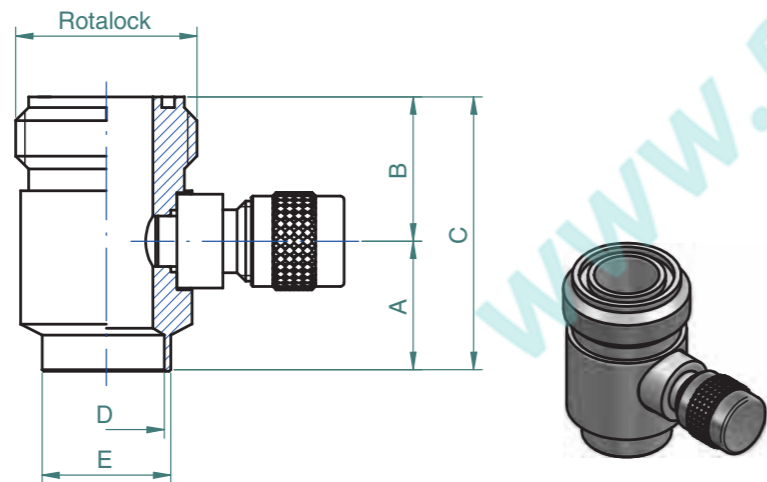

Rotalock	A mm	B mm	C mm	D mm	E mm	CODE
3/4" - 16 UNF	18	20	38	Ø9	Ø16	42051
1" - 14 UNS	18	20	38	Ø16,2	Ø18	42052
1 1/4" - 12 UNF	20	24	44	Ø20	Ø25	42053
1 3/4" - 12 UN	20	24	44	Ø34	Ø38	42054
1" - 14 UNS	40	20	60	Ø16,2	Ø18	42055
1 1/4" - 12 UNF	40	24	64	Ø20	Ø25	42056
1 3/4" - 12 UN	40	24	64	Ø34	Ø38	42057

RACCORDI ROTALOCK A SALDARE
Rotalock soldering connections

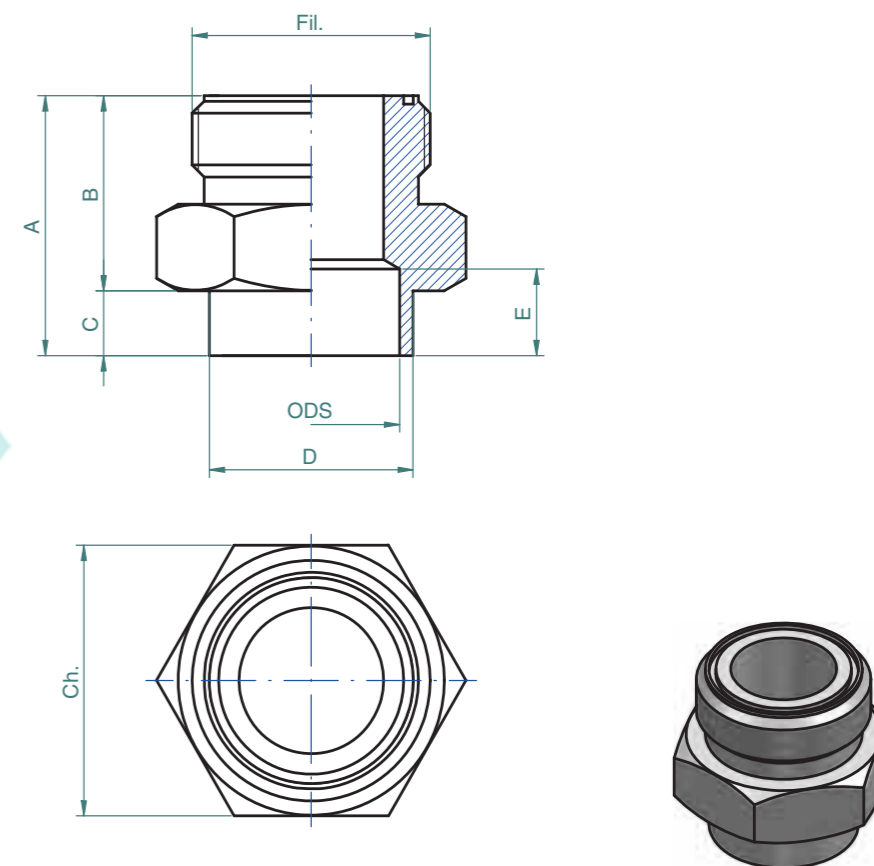

Fil.	ODS		Ch. mm	A mm	B mm	C mm	D mm	E mm	CODE
	mm	inch.							
3/4" - 16 UNF	10		19	23	18	5	Ø13	8	4405.001.0
	12						Ø16	8	4405.002.0
		1/2"					Ø16	8	4405.003.0
1" - 14 UNS	10		27	28	22	6	Ø13	8	4405.004.0
	12						Ø16	8	4405.005.0
		1/2"					Ø16	8	4405.006.0
	16						Ø19	10	4405.007.0
	18						Ø22	10	4405.008.0
		3/4"					Ø22	10	4405.009.0
1 1/4" - 12 UNF	16		32	35	27	8	Ø20	10	4405.026.0
	18						Ø22	10	4405.010.0
		3/4"					Ø22	10	4405.011.0
	22						Ø26	12	4405.012.0
		7/8"					Ø26	12	4405.013.0
	26,6						Ø32	14	4405.024.0
	28						Ø32	14	4405.014.0
1 3/4" - 12 UN	28		46	38	28	10	Ø32	14	4405.015.0
		1 1/8"					Ø32	14	4405.016.0
	33						Ø39	16	4405.025.0
	35						Ø39	16	4405.017.0
	42						Ø46	20	4405.022.0
2 1/4" - 12 UN	35		60	53	37	16	Ø39	20	4405.023.0
	42						Ø46	20	4405.018.0
	54						Ø58	22	4405.019.0
	66						Ø70	22	4405.020.0

Trattamento superficiale: ramatura.
Surface treatment: steel copper galvanized.

DADI E GAMBI
Nuts and Shanks

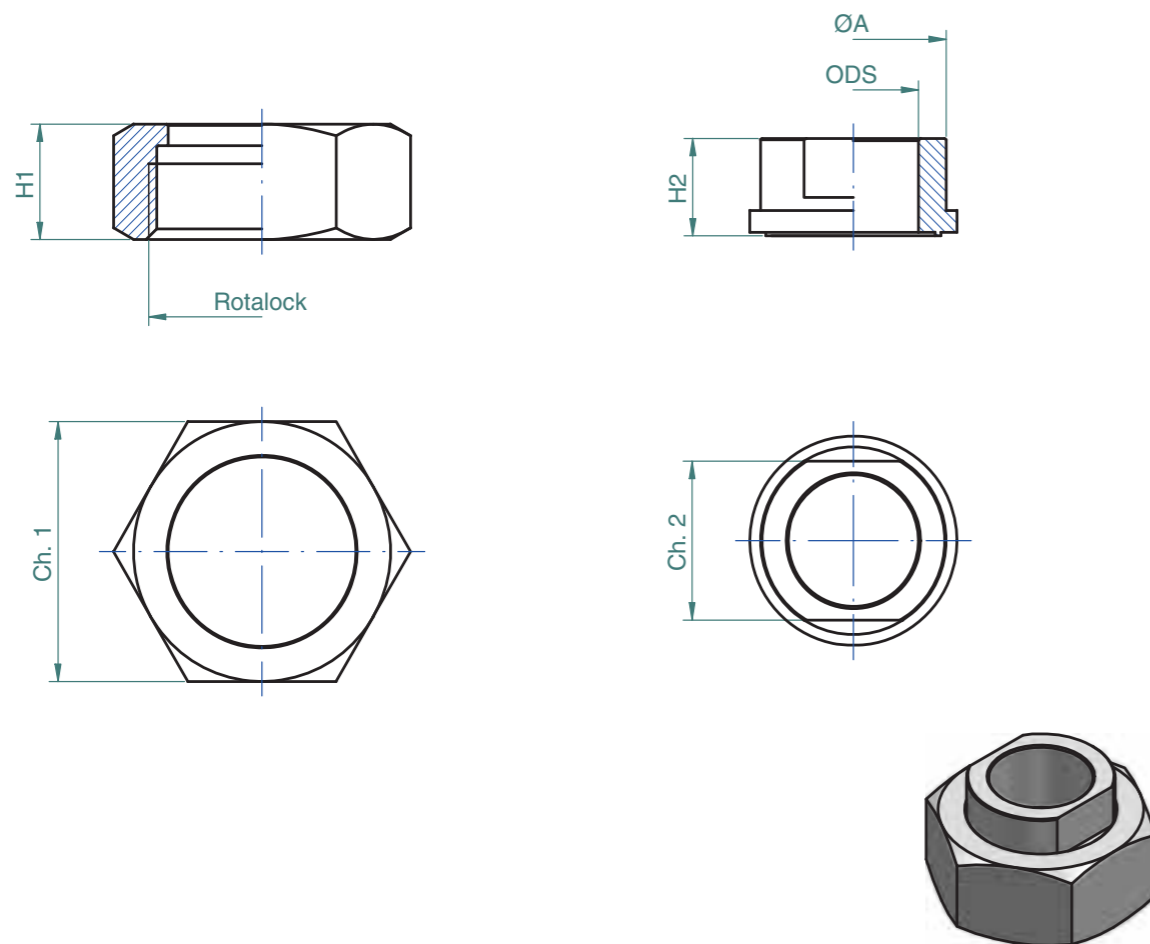

Cod. dado	Rotalock	Ch. 1 mm	H1 mm	Cod. gambo	ODS		Ch. 2 mm	H2 mm	ØA mm
					mm	inch.			
2043.001.0	3/4" - 16 UNF	24	16	2042.005.0		1/4"	12	12	14,3
				2042.008.0		1/4"	13	12	14,3
				2042.006.0		3/8"	13	12	14,3
2043.002.1	1 - 14" UNS	30	16	2042.007.0		1/4"	16	12,5	18
				2042.009.0	8		16	12,5	18
				2042.002.0		3/8"	16	12,5	18
				2042.010.0	10		16	12,5	18
				2042.003.0	12		16	12,5	18
				2042.004.0		1/2"	16	12,5	18
				2042.004.0		3/8"	24	13,5	26
3043.001.0	1 1/4" - 12 UNF	36	16	3042.005.0		3/8"	17	13,5	26
				3042.004.0		3/8"	24	13,5	26
				3042.007.0	12		17	13,5	26
				3042.001.0		1/2"	17	13,5	26
				3042.009.0	14		19	13,5	26
				3042.002.0	16	5/8"	19	13,5	26
				3042.006.0	18		22	13,5	26
				3042.003.0		3/4"	22	13,5	26
				3042.008.0		7/8"	25	13,5	26
				3542.001.0		3/4"	24	13,5	37,5
3543.001.0	1 - 3/4" - 12 UN	50	17	3542.002.0	22	7/8"	27	13,5	37,5
				3542.004.0	28		32	13,5	37,5
				3542.003.0		1 1/8"	32	13,5	37,5
				5324.002.0		1 1/8"	41	16,2	46
5325.001.1	2 - 1/4" - 12 UN	65	19	5324.003.0		1 3/8"	41	16,2	46
				5324.004.0		1 5/8"	45	16,2	46

RACCORDI SPECIALI A RICHIESTA
Special connections on demand

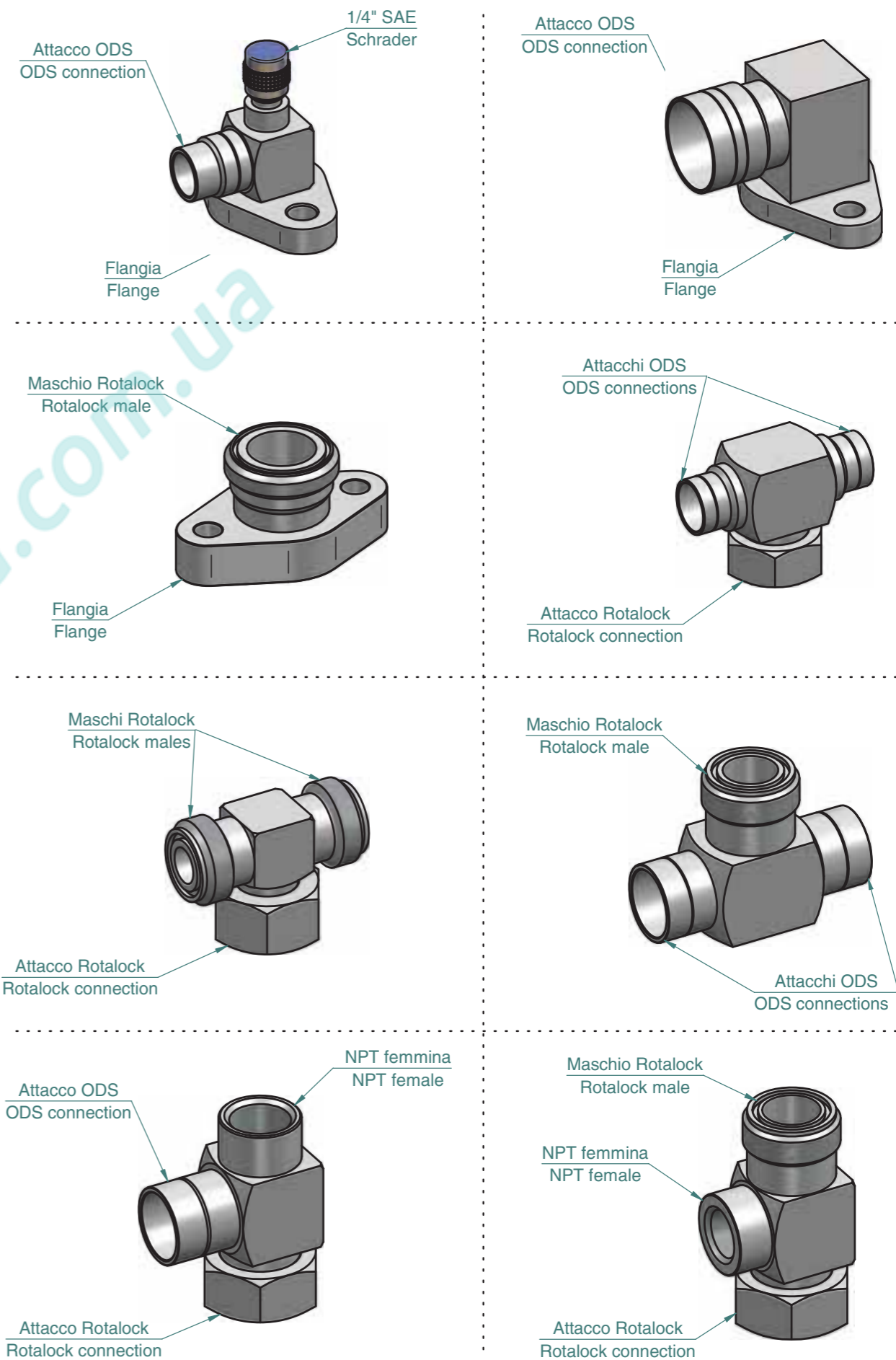

RACCORDI SPECIALI A RICHIESTA
Special connections on demand

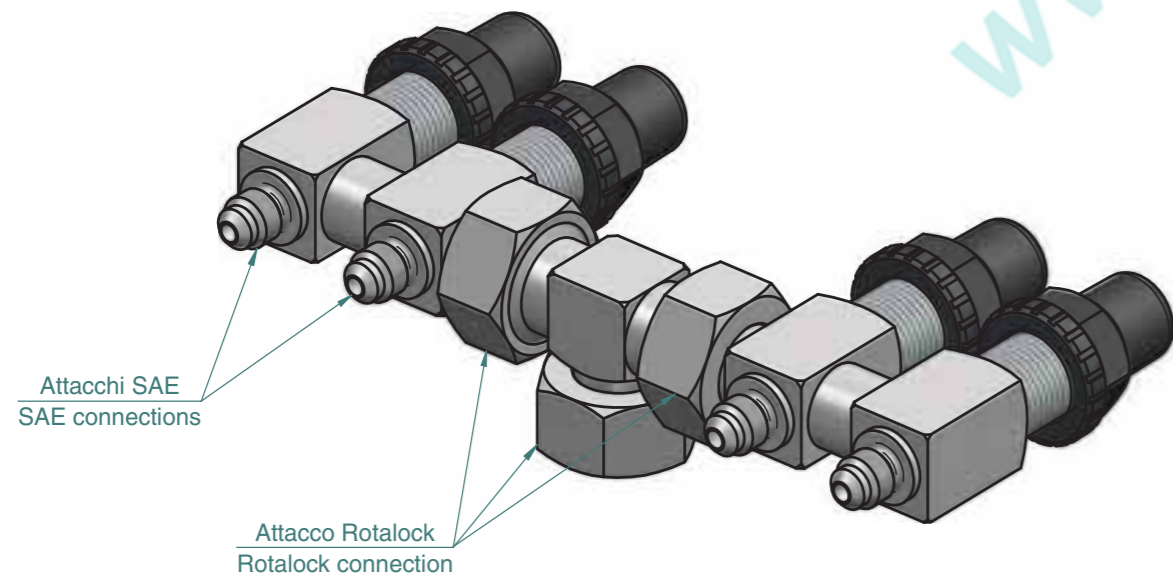
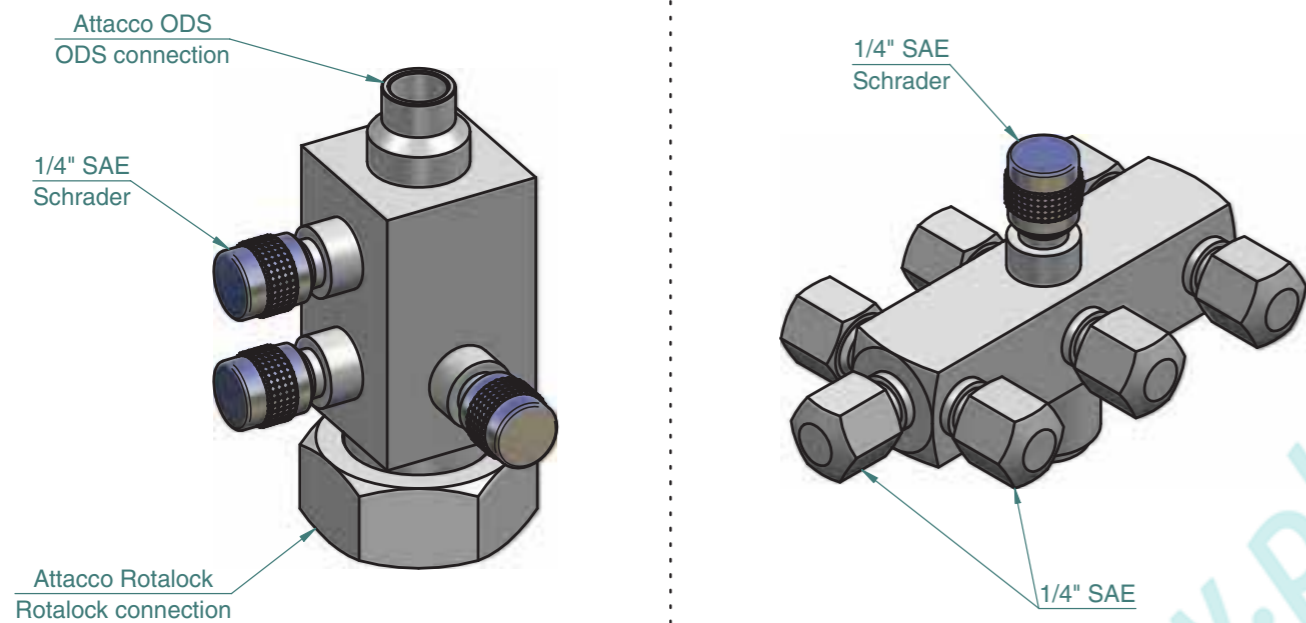

GOMITI IN OTTONE - Brass elbow

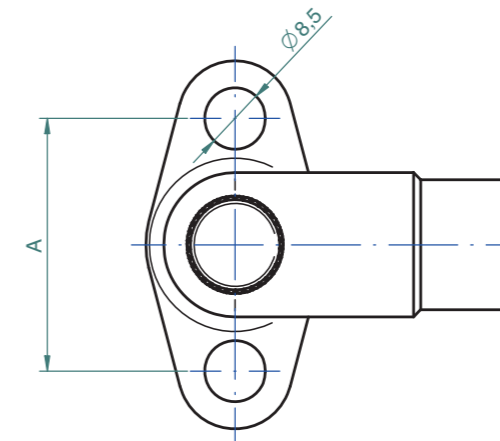
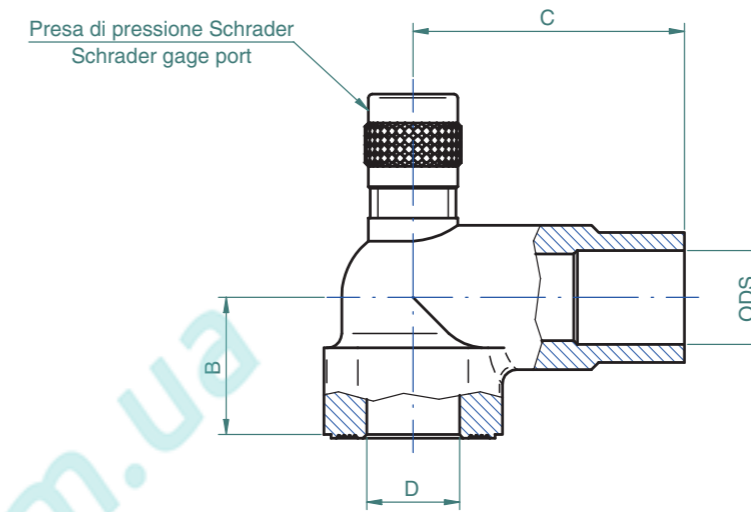

MODELLO Model	ODS inch.	A mm	B mm	C mm	D mm
42781	1/2"	35	19	38	Ø13
42782	5/8"	35	19	38	Ø13
42783	5/8"	41,3	20	40,5	Ø15
42784	3/4"	41,3	20	40,5	Ø15

RACCORDI IN OTTONE - Brass fittings

Cappuccio sigillante in rame per attacchi flare
Copper bonnet for flare connection

MODELLO Model	Flare	PESO Weight x 100 PCS gr.	n°PCS x conf.
DL B1-4	1/4"	41	100
DL B1-5	5/16"	56	100
DL B1-6	3/8"	91	100
DL B1-8	1/2"	140	100
DL B1-10	5/8"	186	100
DL B1-12	3/4"	443	100



Guarnizione conica in rame per attacchi flare
Conical gasket for flare connection

MODELLO Model	Flare	PESO Weight x 100 PCS gr.	n°PCS x conf.
DL B2-4	1/4"	27	100
DL B2-5	5/16"	30	100
DL B2-6	3/8"	50	100
DL B2-8	1/2"	66	100
DL B2-10	5/8"	86	100
DL B2-12	3/4"	182	100



Giunto a croce
Crosses

MODELLO Model	A Flare	L mm	PESO Weight gr	n°PCS x conf.
DL C1-4	1/4"	48	43	50
DL C1-6	3/8"	65	105	25
DL C1-8	1/2"	69	148	25
DL C1-10	5/8"	72	163	10

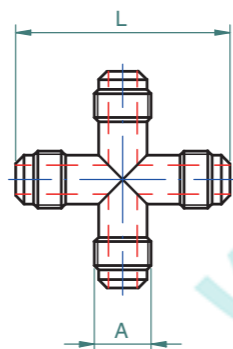

Angolo
Elbows

MODELLO Model	A Flare	L mm	PESO Weight gr	n°PCS x conf.
DL E2-4	1/4"	23	20	100
DL E2-5	5/16"	26	26	50
DL E2-6	3/8"	30	52	50
DL E2-8	1/2"	34	86	50
DL E2-10	5/8"	34	92	25
DL E2-12	3/4"	46	192	10

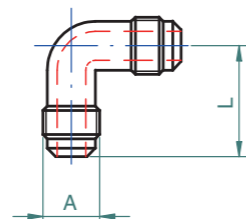

Angolo ridotto
Reduced elbows

MODELLO Model	A Flare	B Flare	L mm	PESO Weight gr.	n°PCS x conf.
DL ER2-64	1/4"	3/8"	30	51	50
DL ER2-84	1/4"	1/2"	34	81	25
DL ER2-86	3/8"	1/2"	34	83	25
DL ER2-106	3/8"	5/8"	34	83	10
DL ER2-108	1/2"	5/8"	34	90	10

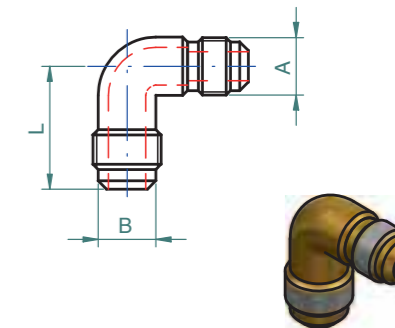

Angolo maschio per femmina
Male to female elbows

MODELLO Model	A Flare	B Flare	L mm	PESO Weight gr.	n°PCS x conf.
DL ER3-44	1/4"	1/4"	27	59	50
DL ER3-46	1/4"	3/8"	30	96	50
DL ER3-66	3/8"	3/8"	30	105	50
DL ER3-68	3/8"	1/2"	30	150	25
DL ER3-88	1/2"	1/2"	38	154	25
DL ER3-810	1/2"	5/8"	38	131	25
DL ER3-1010	5/8"	5/8"	38	138	10
DL ER3-1012	5/8"	3/4"	46	333	10
DL ER3-1212	3/4"	3/4"	46	350	10

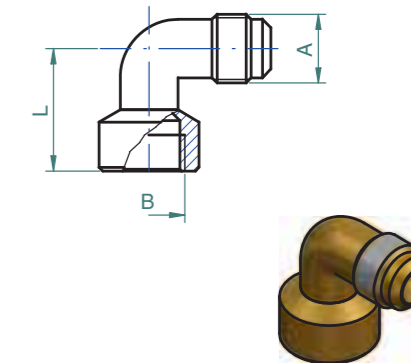

Angolo conico-cilindrico
Male elbows

MODELLO Model	A Flare	B NPT	L mm	PESO Weight gr.	n°PCS x conf.
DL E1-4A	1/4"	1/8"	23	20	100
DL E1-4B	1/4"	1/4"	25	31	100
DL E1-4C	1/4"	3/8"	27	53	100
DL E1-6A	3/8"	1/8"	27	46	50
DL E1-6B	3/8"	1/4"	27	44	50
DL E1-6C	3/8"	3/8"	27	55	50
DL E1-6D	3/8"	1/2"	33	95	50
DL E1-8C	1/2"	3/8"	33	86	50
DL E1-8D	1/2"	1/2"	33	97	50
DL E1-10C	5/8"	3/8"	33	88	25
DL E1-10D	5/8"	1/2"	33	86	25
DL E1-10E	5/8"	3/4"	43	185	10
DL E1-12E	3/4"	3/4"	43	196	10

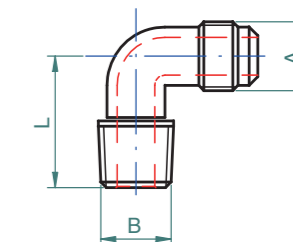

Bocchettoni per tubi in pollici
Nuts for inch tubes

MODELLO Model	A Flare	B Inch.	Ch.	L mm	PESO Weight gr.	n°PCS x conf.
DL NS4-4	1/4"	1/4"	17	15	18	200
DL NS4-5	5/16"	5/16"	19	18	25	100
DL NS4-6	3/8"	3/8"	22	18	31	100
DL NS4-8	1/2"	1/2"	24	20	36	100
DL NS4-10	5/8"	5/8"	27	23	43	50
DL NS4-12	3/4"	3/4"	33	30	87	25
DL NS4-14	7/8"	7/8"	41	36	179	10
DL NS4-16	1"	1"	41	36	149	10

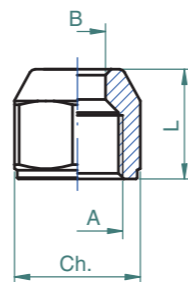

Bocchettoni ridotti per tubi in pollici
Reduced nuts for inch tubes

MODELLO Model	A Flare	B Inch.	Ch.	L mm	PESO Weight gr.	n°PCS x conf.
DL NRS4-53	5/16"	3/16"	19	16	25	100
DL NRS4-54	5/16"	1/4"	19	16	25	100
DL NRS4-64	3/8"	1/4"	22	18	31	100
DL NRS4-65	3/8"	5/16"	22	18	32	100
DL NRS4-86	1/2"	3/8"	24	20	37	50
DL NRS4-108	5/8"	1/2"	27	25	47	50

Bocchettoni per tubi in millimetri
Nuts for metric tubes

MODELLO Model	A Flare	B mm	Ch.	L mm	PESO Weight gr.	n°PCS x conf.
DL NS4-4/6	1/4"	6	17	15	19	200
DL NS4-6/6	3/8"	6	22	18	33	100
DL NS4-6/8	3/8"	8	22	18	33	100
DL NS4-6/9	3/8"	9	22	18	33	100
DL NS4-6/10	3/8"	10	22	18	31	100
DL NS4-8/10	1/2"	10	24	20	38	100
DL NS4-8/12	1/2"	12	24	20	37	100
DL NS4-8/14	1/2"	14	24	20	34	100
DL NS4-10/12	5/8"	12	27	23	47	50
DL NS4-10/15	5/8"	15	27	23	46	50
DL NS4-10/16	5/8"	16	27	23	44	50
DL NS4-12/15	3/4"	15	33	30	100	25
DL NS4-12/16	3/4"	16	33	30	94	25
DL NS4-12/18	3/4"	18	33	30	89	25
DL NS4-14/22	7/8"	22	41	36	158	10
DL NS4-16/22	1"	22	41	36	159	10

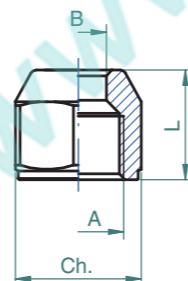

Bocchettone cieco
Flare caps

MODELLO Model	A Flare	Ch.	L mm	PESO Weight gr.	n°PCS x conf.
DL N5-4	1/4"	14	14	10	100
DL N5-6	3/8"	22	18	33	100
DL N5-8	1/2"	24	20	40	50
DL N5-10	5/8"	27	23	50	25

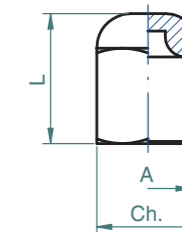

Bocchettoni gas
Gas caps

MODELLO Model	A gas	B mm	Ch.	L mm	PESO Weight gr.	n°PCS x conf.
DL 78-4/6	1/4"	6	19	16	26	100
DL 78-6/6	3/8"	6	22	18	31	100
DL 78-6/8	3/8"	8	22	18	32	100
DL 78-6/9	3/8"	9	22	18	31	100
DL 78-6/10	3/8"	10	22	18	30	100
DL 78-8/10	1/2"	10	27	23	55	50
DL 78-8/12	1/2"	12	27	23	51	50
DL 78-8/14	1/2"	14	27	23	43	50
DL 78-10/12	5/8"	12	29	26	57	25
DL 78-10/14	5/8"	14	29	26	45	25
DL 78-10/15	5/8"	15	29	26	50	25
DL 78-10/16	5/8"	16	29	26	54	25
DL 78-12/16	3/4"	16	33	30	94	10
DL 78-12/18	3/4"	18	33	30	92	10

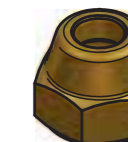
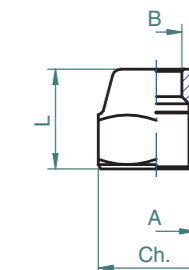

Tappo con fil. cilindrica
Flare plugs

MODELLO Model	A Flare	Ch.	L mm	PESO Weight gr.	n°PCS x conf.
DL P2-4	1/4"	12	20	13	100
DL P2-5	5/16"	15	21	27	50
DL P2-6	3/8"	17	23	36	50
DL P2-8	1/2"	20	26	55	25
DL P2-10	5/8"	23	31	94	25
DL P2-12	3/4"	28	36	154	10

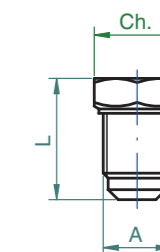

Tappo con fil. conica
NPT plugs

MODELLO Model	A NPT	Ch.	L mm	PESO Weight gr.	n°PCS x conf.
DL P3-A	1/8"	12	17	13	100
DL P3-B	1/4"	14	22	25	100
DL P3-C	3/8"	17	22	39	50
DL P3-D	1/2"	22	25	74	25
DL P3-E	3/4"	27	34	158	10

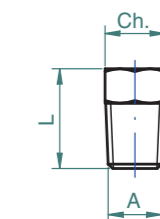

Giunto a T
Tees

MODELLO Model	A Flare	L mm	M mm	PESO Weight gr.	n°PCS x conf.
DL T2-4	1/4"	46	22	30	100
DL T2-5	5/16"	47	23	35	50
DL T2-6	3/8"	52	26	59	50
DL T2-8	1/2"	60	31	95	25
DL T2-10	5/8"	70	35	145	25
DL T2-12	3/4"	80	41	225	10

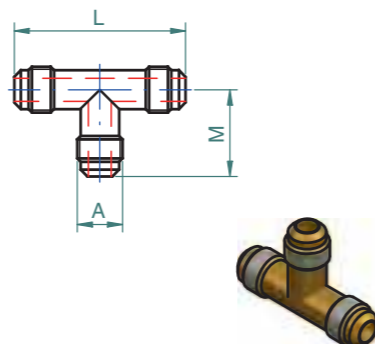

Giunto a T con attacco centrale conico
Male branch tees

MODELLO Model	A Flare	B NPT	L mm	M mm	PESO Weight gr.	n°PCS x conf.
DL T1-4A	1/4"	1/8"	46	22	29	100
DL T1-4B	1/4"	1/4"	48	25	40	100
DL T1-6B	3/8"	1/4"	53	28	55	50
DL T1-6C	3/8"	3/8"	53	28	65	50
DL T1-8C	1/2"	3/8"	61	28	90	25
DL T1-8D	1/2"	1/2"	68	31	120	25

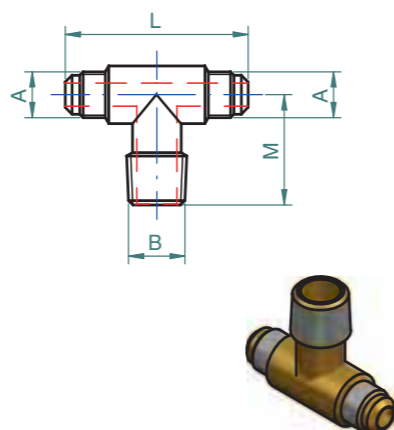

Giunto a T con attacco centrale maggiorato
Oversized branch tees

MODELLO Model	A Flare	B Flare	L mm	M mm	PESO Weight gr.	n°PCS x conf.
DL TR2-464	1/4"	3/8"	55	28	59	50
DL TR2-686	3/8"	1/2"	61	31	93	50
DL TR2-8108	1/2"	5/8"	71	35	146	25
DL TR2-101210	5/8"	3/4"	71	45	195	10

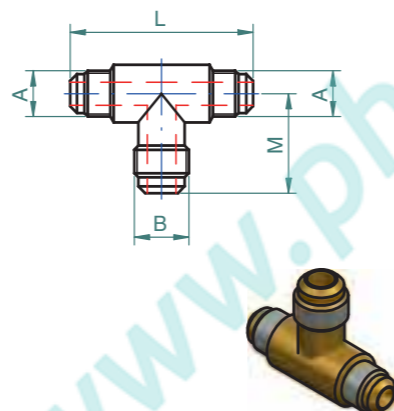

Giunto a T con attacco centrale ridotto
Undersized branch tees

MODELLO Model	A Flare	B Flare	L mm	M mm	PESO Weight gr.	n°PCS x conf.
DL TR2-646	3/8"	1/4"	53	28	61	50
DL TR2-868	1/2"	3/8"	68	31	92	50
DL TR2-10810	5/8"	1/2"	68	31	150	25
DL TR2-121012	3/4"	5/8"	80	35	210	10

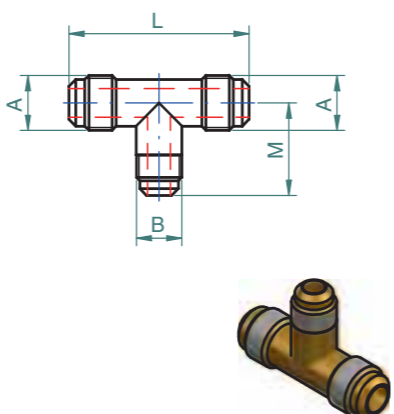

Giunto a T con attacco centrale femmina
Female branch tees

MODELLO Model	A Flare	B Flare	L mm	M mm	PESO Weight gr.	n°PCS x conf.
DL T6-4	1/4"	1/4"	48	25	42	50

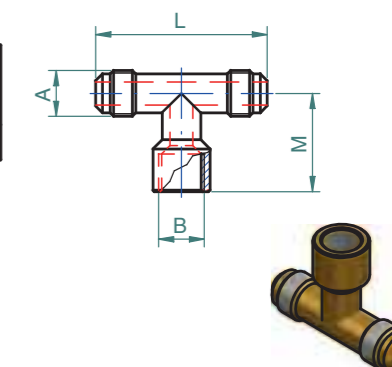

Giunto a T con attacco centrale con bocchettone girevole
Tees with swivel nut branch

MODELLO Model	A Flare	B Flare	Ch.	L mm	M mm	PESO Weight gr.	n°PCS x conf.
DL TRS-4	1/4"	1/4"	17	46	34	52	25
DL TRS-64	1/4"	3/8"	19	46	32	85	10
DL TRS-6	3/8"	3/8"	19	55	36	90	10

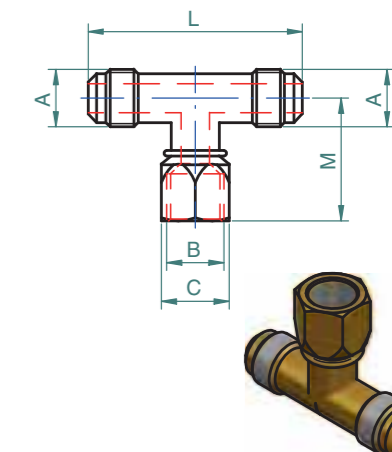

Giunto a doppia cartella
Unions

MODELLO Model	A Flare	Ch.	L mm	PESO Weight gr.	n°PCS x conf.
DL U2-4	1/4"	11	33	17	200
DL U2-5	5/16"	14	36	26	100
DL U2-6	3/8"	17	39	40	100
DL U2-8	1/2"	20	45	68	50
DL U2-10	5/8"	23	50	94	25
DL U2-12	3/4"	27	57	146	10

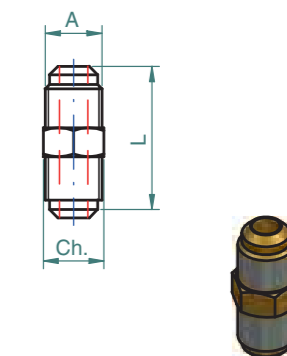

Giunto diritto ridotto a doppia cartella
Reduced unions

MODELLO Model	A Flare	B Flare	Ch.	L mm	PESO Weight gr.	n°PCS x conf.
DL UR2-64	1/4"	3/8"	17	39	36	100
DL UR2-84	1/4"	1/2"	20	42	52	100
DL UR2-86	3/8"	1/2"	20	44	75	100
DL UR2-104	1/4"	5/8"	23	43	66	50
DL UR2-106	3/8"	5/8"	23	45	74	50
DL UR2-108	1/2"	5/8"	23	48	80	25
DL UR2-128	1/2"	3/4"	27	52	114	10
DL UR2-1210	5/8"	3/4"	27	54	132	10

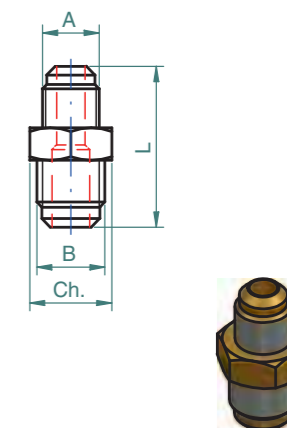

Giunto diritto conico-cilindrico
Male unions

MODELLO Model	A Flare	B NPT	Ch.	L	PESO Weight gr.	n°PCS x conf.
DL U1-4A	1/4"	1/8"	11	31	16	200
DL U1-4B	1/4"	1/4"	14	36	29	100
DL U1-4C	1/4"	3/8"	17	38	41	100
DL U1-4D	1/4"	1/2"	22	42	72	50
DL U1-6A	3/8"	1/8"	17	36	33	50
DL U1-6B	3/8"	1/4"	17	39	36	50
DL U1-6C	3/8"	3/8"	17	39	46	50
DL U1-6D	3/8"	1/2"	22	45	76	50
DL U1-8B	1/2"	1/4"	20	43	54	50
DL U1-8C	1/2"	3/8"	20	43	60	50
DL U1-8D	1/2"	1/2"	22	45	83	50
DL U1-8E	1/2"	3/4"	27	50	113	25
DL U1-10C	5/8"	3/8"	23	47	81	25
DL U1-10D	5/8"	1/2"	23	49	88	25
DL U1-10E	5/8"	3/4"	27	54	132	25
DL U1-12D	3/4"	1/2"	27	53	120	10
DL U1-12E	3/4"	3/4"	27	53	138	10

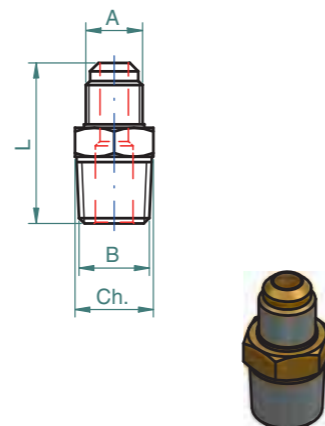

Giunto diritto a manicotto
Coupling unions

MODELLO Model	A Flare	Ch.	L mm	PESO Weight gr.	n°PCS x conf.
DL U4-4	1/4"	17	26	38	100
DL U4-5	5/16"	19	28	65	100
DL U4-6	3/8"	22	30	64	50
DL U4-8	1/2"	25	35	89	25
DL U4-10	5/8"	28	40	124	25

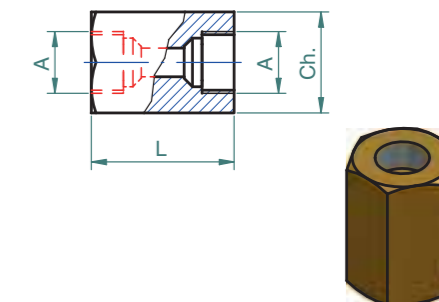

Giunto diritto ridotto flare f. per NPT
Reducing unions flare f. for NPT

MODELLO Model	A Flare	B NPT	Ch.	L mm	PESO Weight gr.	n°PCS x conf.
DL US-4A	1/4"	1/8"	17	28	31	100
DL US-4B	1/4"	1/4"	17	30	39	100
DL US-6B	3/8"	1/4"	22	34	51	50
DL US-6C	3/8"	3/8"	22	34	65	50
DL US-6D	3/8"	1/2"	22	36	65	25

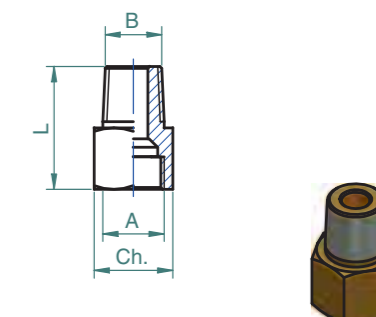

Giunto diritto ridotto maschio per femmina
Male to female reduced unions

MODELLO Model	A Flare	B Flare	Ch.	L mm	PESO Weight gr.	n°PCS x conf.
DL UR3-46	1/4"	3/8"	22	33	50	50
DL UR3-48	1/4"	1/2"	25	37	73	50
DL UR3-64	3/8"	1/4"	17	33	40	50
DL UR3-68	3/8"	1/2"	25	38	73	25
DL UR3-84	1/2"	1/4"	20	35	58	25
DL UR3-86	1/2"	3/8"	22	35	60	25
DL UR3-810	1/2"	5/8"	27	43	97	25
DL UR3-108	5/8"	1/2"	25	43	83	25
DL UR3-1012	5/8"	3/4"	32	45	129	10
DL UR3-1210	3/4"	5/8"	27	41	102	10

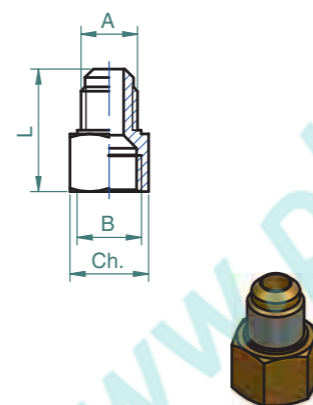

Giunto diritto a doppio bocchettone
Swivel nut unions

MODELLO Model	A Flare	Ch.	L mm	PESO Weight gr.	n°PCS x conf.
DL US4-4	1/4"	17	30	38	100
DL US4-5	5/16"	19	36	58	50
DL US4-6	3/8"	22	37	65	50
DL US4-8	1/2"	24	41	78	50
DL US4-10	5/8"	27	42	91	25
DL US4-12	3/4"	33	58	179	10

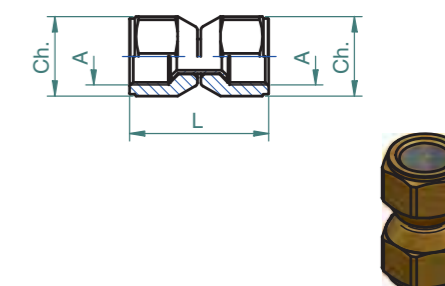

Giunto diritto ridotto flare per NPT f
Reducing unions flare per NPT f

MODELLO Model	A Flare	B NPT	Ch.	L mm	PESO Weight gr.	n°PCS x conf.
DL U3-4A	1/4"	1/8"	14	28	20	200
DL U3-4B	1/4"	1/4"	19	33	41	100
DL U3-4C	1/4"	3/8"	22	36	55	100
DL U3-6A	3/8"	1/8"	17	33	45	100
DL U3-6B	3/8"	1/4"	19	33	49	100
DL U3-6C	3/8"	3/8"	22	35	54	100
DL U3-6D	3/8"	1/2"	27	40	85	50
DL U3-8B	1/2"	1/4"	20	36	52	50
DL U3-8C	1/2"	3/8"	22	38	63	50
DL U3-8D	1/2"	1/2"	27	44	100	50

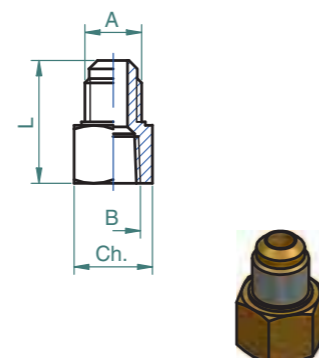

Giunto diritto a doppio bocchettone ridotto
Reduced swivel nut unions

MODELLO Model	A Flare	B Flare	Ch. 1	Ch. 2	L mm	PESO Weight gr.	n°PCS x conf.
DL URS4-64	3/8"	1/4"	22	17	33	53	50
DL URS4-65	3/8"	5/16"	22	19	35	65	25
DL URS4-86	1/2"	3/8"	24	22	38	71	25
DL URS4-108	5/8"	1/2"	27	24	41	90	10
DL URS4-1210	3/4"	5/8"	33	27	52	146	10

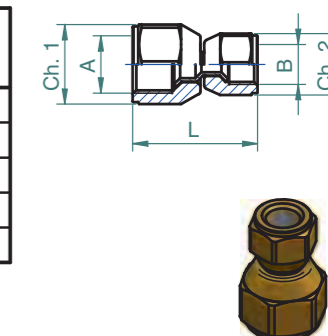

RACCORDI PER MECCANISMO DI CARICA - Access Valves

Raccordo diritto SAE
Flare unions

MODELLO Model	A Flare	B Flare	L mm	Ch. mm	PESO Weight gr.
DL 885	1/4"	Schrader	35	11	22

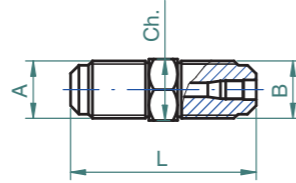

Raccordo diritto SAE per NPT
Flare for NPT unions

MODELLO Model	A Flare	B Flare	L mm	Ch. mm	PESO Weight gr.
DL 886	1/8"	Schrader	32	11	20
DL 886/01	1/4"	Schrader	37	11	32

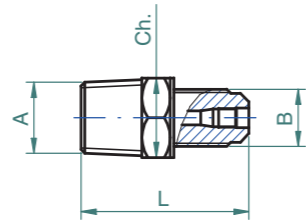

Raccordo diritto SAE per saldare
Flare unions for O.D.S.

MODELLO Model	A Flare	B		L mm	Ch. mm	PESO Weight gr.
		mm	ODS			
DL 888/4M6	Schrader	6	-	25	11	20
DL 886/4P14	Schrader	-	1/4"	25	11	32

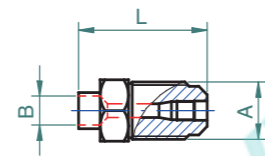

Raccordo a T
Tees

MODELLO Model	A NPT	B Flare	C Flare	L mm	PESO Weight gr.
DL 889	1/8"	Schrader	1/4"	45	28
DL 889/01	1/8"	1/4"	Schrader	45	28
DL 889/02	1/8"	Schrader	Schrader	45	25
DL 889/03	1/4"	Schrader	1/4"	48	38
DL 889/04	1/4"	1/4"	Schrader	48	38
DL 889/05	1/4"	Schrader	Schrader	48	35

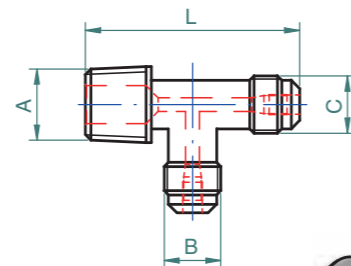

Raccordo a T
Tees

MODELLO Model	A Flare	B Flare	C Flare	L mm	PESO Weight gr.
DL 890	Schrader	1/4"	1/4"	45	28
DL 890/01	1/4"	Schrader	1/4"	45	28
DL 890/02	Schrader	Schrader	1/4"	45	25

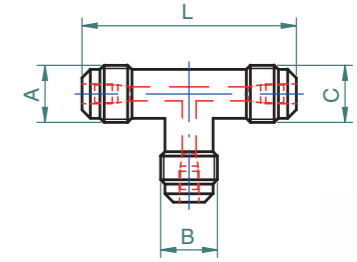

Raccordo a T con bocchettone girevole
Tees with swivel nut

MODELLO Model	A Flare	B Flare	C Flare	L mm	PESO Weight gr.
DL 891	1/4" N	Schrader	1/4"	52	50
DL 891/01	Schrader	1/4" N	1/4"	45	50
DL 891/02	1/4" N	Schrader	Schrader	52	47
DL 891/03	Schrader	1/4" N	Schrader	45	47

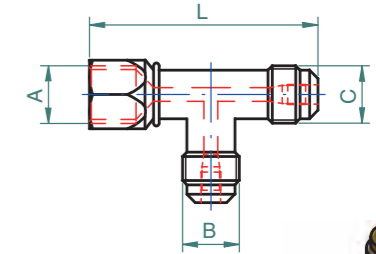

Raccordo a T
Tees

MODELLO Model	A Flare	B Flare	L mm	PESO Weight gr.
DL 892	Schrader	1/4" N	40	23
DL 892/01	1/4" N	Schrader	40	23
DL 892/02	Schrader	Schrader	40	20

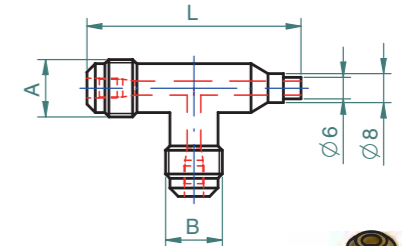

Raccordo a T
Tees

MODELLO Model	A Flare	B Flare	L mm	PESO Weight gr.
DL T6-4C	Schrader	1/4"	46	40
DL T6-4C/01	Schrader	Schrader	46	37

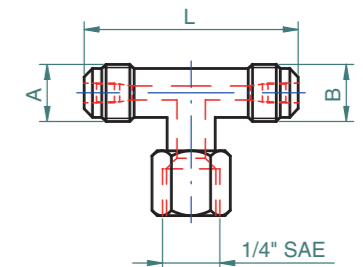



denaline

Via Segaluzza 11B
33170 Pordenone Italy
Tel. +39.0434.572710
Fax +39.0434.572802
www.denaline.it
denaline@denaline.it

www.pholod.com.ua