

www.pholod.com.ua



HANDBOOK
SOLENOID VALVES

Ed. 2017



NORMALLY-CLOSED SOLENOID VALVES

FOR REFRIGERATION PLANTS THAT USE HCFC, HFC OR HFO REFRIGERANTS



APPLICATION

The solenoid valves illustrated in this chapter are designed for installation on commercial refrigeration systems and on civil and industrial air conditioning plants that use the following refrigerant fluids:

- HCFC (R22)
- HFC (R134a , R404A , R407C , R410A , R507)
- HFO and HFO/HFC mixtures (R1234ze , R448A , R449A , R450A , and R452A)

belonging to Group 2, as defined in Article 13, chapter 1, Point (b) of Directive 2014/68/EU, with reference to EC Regulation No. 1272/2008.

Furthermore, the same solenoid valves, up to DN 25, that is models 1078*9, 1098/9, 1079/11 and 1099/11, can also be installed on systems using the following refrigeration fluids:

- HFC (R32)
- HFO (R1234yf)

classified as A2L in the ASHRAE 34-2013 standard, and belonging to Group 1, as defined in Article 13, chapter 1, Point (a) of Directive 2014/68/EU, with reference to EC Regulation No. 1272/2008.

For specific applications with refrigerant fluids not listed above, please contact Castel Technical Department.

OPERATION

The coils listed in this chapter are normally closed (NC). This means that when the coil is not energised, the plunger closes the fluid passage. When the coil is energised, the plunger opens the valve seat connecting the inlet to the outlet.

All the above indicated valves are sold in the version without coil (with the S suffix), and in the version with coil series 9300, type HF2 - "FAST LOCK" (A6 suffix with coil 9300/RA6-220/230 VAC and A7 suffix with coil 9300/RA7 - 240 VAC).

The valves series 1020 and 1028 are direct acting valves. Their operation depends only on the magnetic field produced by the current flow into the coil. Opening/closing of main valve seat, the only seat, is directly controlled by the mobile plunger.

These valves can work with zero pressure differential.

The valves series 1064 ; 1068 ; 1070 ; 1078 (excluded /11 , /13 , and /M42) ; 1079 (excluded /13 , /M42 , and /17) ; 1090 ; 1098 (excluded /9) ; 1099 (excluded /11) are pilot-operated diaphragm solenoid valves. Their operation depends not only on the magnetic field produced by the current flow into the coil, but also on a minimum inlet pressure, which is necessary to:

- open the diaphragm and keep it lifted off the main opening
- close the diaphragm and ensure the tightness on the main opening

Opening/closing of main valve seat is controlled by the diaphragm while opening/closing of pilot seat is controlled by the mobile plunger of the coil.

These valves cannot work with zero differential pressure.

The valve series 1034 ; 1038 ; 1040 ; 1048 ; 1049 ; 1050 ; 1058 ; 1059 ; 1078 (/11 , /13 , /M42) ; 1079 (/13 , /M42 , /17) ; 1098/9 ; 1099/11 are piston pilot-operated valves. Their operation depends not only on the magnetic field produced by the current flow into the coil, but also on a minimum inlet pressure, which is necessary to:

- open the piston and keep it lifted off the main opening
- close the piston and ensure the tightness on the main opening

Opening/closing of main valve seat is controlled by the piston, while opening/closing of pilot seat is controlled by the mobile plunger of the coil.

These valves cannot work with zero differential pressure.

CONSTRUCTION

The main parts that make up the solenoid valves presented in this chapter are constructed with the following materials:

- Hot forged brass EN 12420 – CW 617N for body and cover
- Copper tube EN 12735-1 – Cu-DHP for solder connections
- Austenitic stainless steel EN 10088-2 – 1.4303 for enclosure where the plunger moves
- Ferritic stainless steel EN 10088-3 – 1.4105 for the plunger
- Austenitic stainless steel EN ISO 3506 – A2-70 for tightening screws between body and cover.
- Chloroprene rubber (CR) for the outlet seal gaskets
- P.T.F.E. for seat gaskets

INSTALLATION

All the valves in this chapter can be installed on the three main branches of a plant (hot gas line, liquid line, and suction line), while respecting the limits of use indicated in TABLES 1 and 2 and the capacities indicated in TABLE 4. TABLES 1 and 2 show the following functional characteristics of a solenoid valve:

- Connection dimensions
- PS: maximum allowable pressure of the refrigerant
- TS: maximum / minimum allowable temperature of the refrigerant
- TA: maximum / minimum allowable ambient temperature
- Kv: discharge factor
- minOPD: minimum Opening Pressure Differential. This is the minimum pressure differential between inlet and outlet at which a pilot-operated solenoid valve can

open and stay opened or close and maintain the seal.

- MOPD: maximum opening pressure differential according to AHRI STANDARD 760:2014. This is the maximum pressure differential between inlet and outlet at which a solenoid valve can open.

Before connecting the valve to the pipe, it is advisable to make sure that the refrigerating system is clean. In fact, valves with P.T.F.E. gaskets, and particularly piston valves, are sensitive to dirt and debris. Furthermore, check that the flow direction in the pipe corresponds to the arrow stamped on the valve body. All the valves can be mounted in any position so long as the coil does not point downwards. The brazing of valves with solder connections should be carried out with care, using a low melting point filler material. It is not necessary to disassemble the valves before brazing, but it is important to avoid direct contact between the torch flame and the valve body, which could be damaged and compromise the proper functioning of the valve.

Before connecting a valve to the electrical system, be sure that the line voltage and frequency correspond to the values marked on the coil.

TRACEABILITY

Direct action valves in series 1020 and 1028 are identified by laser marking on the valve sleeve of the mobile plunger. This marking includes the following data: valve code, refrigerants, PS, TS, and production lot.

The pilot-operated diaphragm and piston valves, series 1034, 1038, 1040, 1048, 1049, 1050, 1058, 1059, 1064, 1068, 1070, 1078, 1079, 1090, 1098, and 1099 are identified by a plastic label fit on the valve sleeve of the mobile plunger (under the coil when indicated). This label includes the following data: valve code, refrigerants, PS, TS, and production lot.

TABLE 1: General characteristics of NC valves with SAE Flare connections

Operating Principles	Catalogue Number	SAE Flare Connections	Seat size nominal Ø [mm]	Kv Factor [m³/h]	Opening Pressure Differential [bar]				PS [bar]	TS [°C]		TA [°C]		Risk Category according to PED Recast	
					min OPD	MOPD				min.	max.	min. (3)	max.		
						coil series									
						9100 9110 9300 (AC)	9160 (AC)	9120 9320 (AC)							9120 9320 (DC)
Direct Acting	1020/2#	1/4"	2,5	0,175	0	21	28	35	21	45	-35	+110 (2)	-35	+50	Art. 4.3
	1020/3#	3/8"	3	0,23											
Diaphragm Pilot Operated	1064/3#	3/8"	6,5	0,80	0,05	21	28	35	18	45	-35	+105 (1)	-35	+50	Art. 4.3
	1064/4#	1/2"													
	1070/4#	1/2"	12,5	2,20					13						
	1070/5#	5/8"	2,61												
	1090/5#	5/8"	16,5	3,80					10						
	1090/6#	3/4"		4,80											
Piston Pilot Operated	1034/3#	3/8"	6,5	1,00	0,05	21	28	35	18	45	-35	+110 (2)	-35	+50	Art. 4.3
	1034/4#	1/2"													
	1040/4#	1/2"	12,5	2,40					18						
	1040/5#	5/8"	3,00												
	1050/5#	5/8"	16,5	3,80					16						
	1050/6#	3/4"		4,80											

= S , A6 , A7

(1) Temperature peaks of 120 °C are allowed during defrosting

(2) Temperature peaks of 130 °C are allowed during defrosting

(3) Check TA_{min} of the chosen coil

TABLE 2: General characteristics of NC valves with ODS connections

Operating Principles	Catalogue Number	Connections ODS		Seat size nominal Ø [mm]	Kv Factor [m³/h]	Opening Pressure Differential [bar]				PS [bar]	TS [°C]		TA [°C]		Risk Category according to PED Recast											
		Ø [in.]	Ø [mm]			min OPD	MOPD				min.	max.	min. (3)	max.												
							coil series																			
							9100 9110 9300 (AC)	9160 (AC)	9120 9320 (AC)							9120 9320 (DC)										
Direct Acting	1028/2#	1/4"	–	2,2	0,15	0	21	28	35	21	45	– 35	+110 (2)	– 35	+50	Art. 4.3										
	1028/2#.E	1/4"	–	3	0,23																					
	1028/3#	3/8"	–																							
	1028/M10#	–	10																							
Diaphragm Pilot Operated	1068/3#	3/8"	–	6,5	0,80	0,05	21	28	35	18	45	– 35	+105 (1)	– 35	+50	Art. 4.3										
	1068/M10#	–	10																							
	1068/M12#	–	12																							
	1068/4#	1/2"	–																							
	1078/M12#	–	12	12,5	2,20																					
	1078/4#	1/2"	–																							
	1078/5#	5/8"	16	16,5	2,61					13																
	1079/7#	7/8"	22																							
	1098/5#	5/8"	16																							
	1098/6#	3/4"	–	25,5	3,80					0,07							21	28	35	10	45	– 35	+110 (2)	– 35	+50	Art. 4.3
	1098/7#	7/8"	22																							
	1099/9#	1.1/8"	–																							
	1078/9#	1.1/8"	–	16,5	4,80																					
1079/11#	1.3/8"	35																								
1038/3#	3/8"	–	6,5	1,00	0,05	21	28	35	18		45	– 35	+110 (2)	– 35	+50	Art. 4.3										
1038/M10#	–	10																								
1038/M12#	–	12																								
1038/4#	1/2"	–																								
1048/M12#	–	12	12,5	2,40																						
1048/4#	1/2"	–																								
1048/5#	5/8"	16																								
1049/7#	7/8"	22																								
1058/5#	5/8"	16	16,5	3,80																						
1058/6#	3/4"	–																								
1058/7#	7/8"	22																								
1059/9#	1.1/8"	–	25,5	5,70					0,1	21							28	35	16	45	– 35	+110 (2)	– 35	+50	Art. 4.3	
1098/9#	1.1/8"	–																								
1099/11#	1.3/8"	35																								
1078/11#	1.3/8"	35	27	16																						
1079/13#	1.5/8"	–																								
1079/M42#	–	42																								
1078/13#	1.5/8"	–																								
1078/M42#	–	42	34	25	0,15	21	28	35			18	45	– 35	+110 (2)	– 35	+50			I							
1079/17#	2.1/8"	54																								

= S , A6 , A7

(1) Temperature peaks of 120 °C are allowed during defrosting

(2) Temperature peaks of 130 °C are allowed during defrosting

(3) Check TA_{min} of the chosen coil

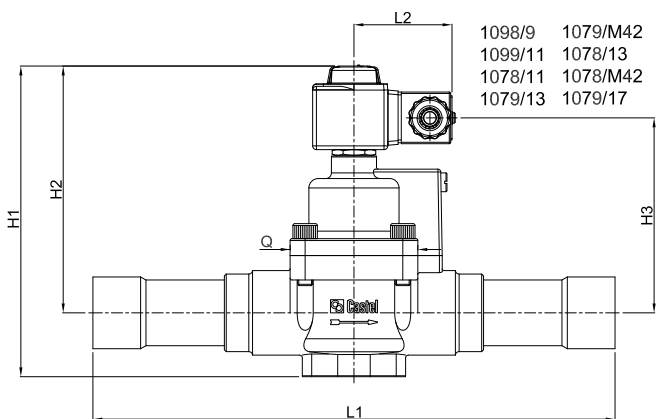
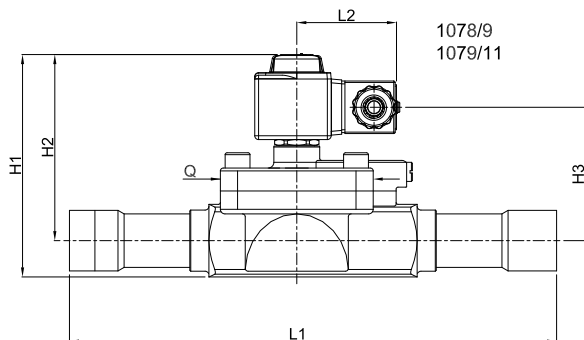
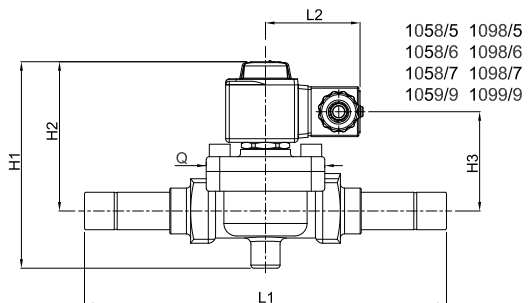
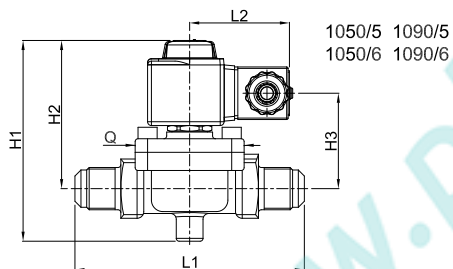
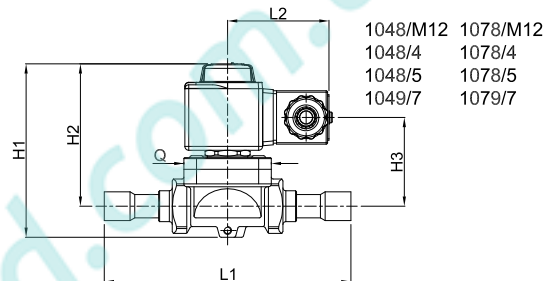
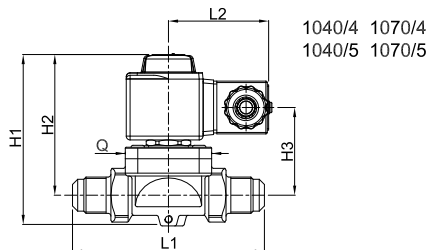
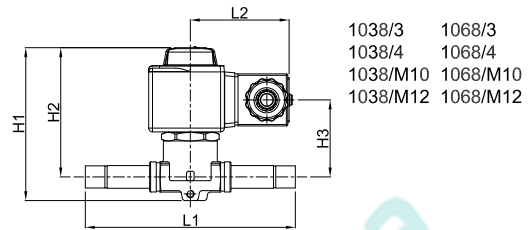
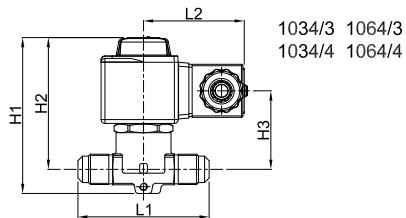
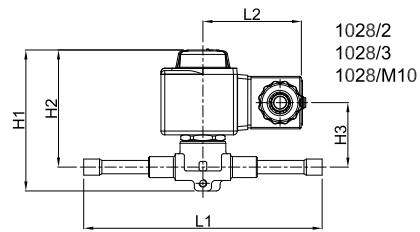
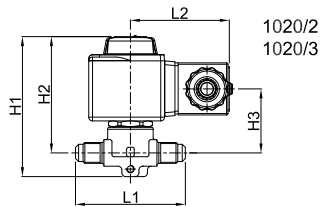

TABLE 3: Dimensions and weights of NC valves with 9300 coils (1)

Operating Principles	Catalogue Number	Dimensions [mm]						Weight [g]
		H ₁	H ₂	H ₃	L ₁	L ₂	Q	
Direct Acting	1020/2#	75	62,5	34	58	52	-	340
	1020/3#				65			355
	1028/2#				125			350
	1028/2#.E				125			350
	1028/3#				125			365
	1028/M10#				125			365
Diaphragm Pilot Operated	1064/3#	82	69,5	40	68	52	-	400
	1064/4#				72			415
	1068/3#				111			400
	1068/M10#				111			395
	1068/M12#				127			420
	1068/4#				127			420
	1070/4#	91	75	47	100		45	710
	1070/5#				106			755
	1078/M12#				127			690
	1078/4#				127			680
	1078/5#				175			775
	1079/7#				190			765
	1090/5#	106	78	50	120		57	1035
	1090/6#				124			1365
	1098/5#				175			995
	1098/6#				175			1185
	1098/7#				180			1170
	1099/9#				216			1225
	1078/9#	115	96	72	250		80	2565
	1079/11#				292			2620
Piston Pilot Operated	1034/3#	92,5	80	50,5	68	52	-	440
	1034/4#				72			457
	1038/3#				111			440
	1038/M10#				111			435
	1038/M12#				127			462
	1038/4#				127			462
	1040/4#	100,5	84,5	56,5	100		45	781
	1040/5#				106			831
	1048/M12#				127			759
	1048/4#				127			748
	1048/5#				175			853
	1049/7#				190			842
	1050/5#	121	93	65	120		57	1157
	1050/6#				124			1487
	1058/5#				175			1117
	1058/6#				175			1307
	1058/7#				180			1292
	1059/9#				216			1347
	1098/9#	157	127	99	235		60	2050
	1099/11#				277			2130
	1078/11#	175	141	113	278		68	2710
	1079/13#							2750
	1079/M42#							2750
1078/13#	190	153	125	280	88	3810		
1078/M42#						3810		
1079/17#						3880		

= S , A6 , A7

(1) : With coil 9320 the dimension L₂ is equal to 65 mm and the weights must be increased of 500 g.

Connectors are not included in the boxes and have to be ordered separately

TABLE 4: Refrigerant flow capacity of NC valves [kW]

Operating Principles	Catalogue Number	Liquid line												
		R134a	R22	R32	R404A	R407C	R410A	R507	R1234yf	R1234ze	R448A	R449A	R450A	R452A
Direct Acting	1020/2#	2,98	3,20	4,40	2,08	3,02	3,00	2,01	2,20	2,63	2,74	2,75	2,78	2,12
	1020/3#	3,91	4,21	5,78	2,74	3,96	3,95	2,65	2,89	3,46	3,60	3,62	3,66	2,79
	1028/2#	2,55	2,75	3,77	1,79	2,58	2,58	1,73	1,89	2,26	2,35	2,36	2,39	1,82
	1028/2#.E	3,91	4,21	5,78	2,74	3,96	3,95	2,65	2,89	3,46	3,60	3,62	3,66	2,79
	1028/3#													
	1028/M10#													
1028/M12#														
Diaphragm Pilot Operated	1064/3#	13,6	14,6	20,1	9,5	13,8	13,7	9,2	10,1	12,0	12,5	12,6	12,7	9,7
	1064/4#													
	1068/3#													
	1068/M10#													
	1068/M12#													
	1068/4#													
	1070/4#	37,4	40,3	55,3	26,2	37,9	37,8	25,3	27,7	33,1	34,4	34,6	35,0	26,7
	1070/5#	44,4	47,8	65,6	31,1	45,0	44,8	30,0	32,8	39,3	40,8	41,0	41,5	31,7
	1078/M12#	37,4	40,3	55,3	26,2	37,9	37,8	25,3	27,7	33,1	34,4	34,6	35,0	26,7
	1078/4#													
	1078/5#	44,4	47,8	65,6	31,1	45,0	44,8	30,0	32,8	39,3	40,8	41,0	41,5	31,7
	1079/7#													
	1090/5#	64,6	69,5	95,5	45,2	65,5	65,2	43,7	47,8	57,2	59,5	59,7	60,5	46,1
	1090/6#	81,6	87,8	120,6	57,1	82,7	82,4	55,2	60,4	72,2	75,1	75,5	76,4	58,2
	1098/5#	64,6	69,5	95,5	45,2	65,5	65,2	43,7	47,8	57,2	59,5	59,7	60,5	46,1
	1098/6#	81,6	87,8	120,6	57,1	82,7	82,4	55,2	60,4	72,2	75,1	75,5	76,4	58,2
	1098/7#	96,9	104,3	143,2	67,8	98,2	97,9	65,6	71,7	85,7	89,2	89,6	90,7	69,1
	1099/9#													
	1078/9#	170,0	183,0	251,3	119,0	172,3	171,7	115,0	125,8	150,4	156,5	157,2	159,1	121,3
	1079/11#													
Piston Pilot Operated	1034/3#	17,0	18,3	25,1	11,9	17,2	17,2	11,5	12,6	15,0	15,7	15,7	15,9	12,1
	1034/4#													
	1038/3#													
	1038/M10#													
	1038/M12#													
	1038/4#													
	1040/4#	40,8	43,9	60,3	28,6	41,4	41,2	27,6	30,2	36,1	37,6	37,7	38,2	29,1
	1040/5#	51,0	54,9	75,4	35,7	51,7	51,5	34,5	37,7	45,1	47,0	47,2	47,7	36,4
	1048/M12#	40,8	43,9	60,3	28,6	41,4	41,2	27,6	30,2	36,1	37,6	37,7	38,2	29,1
	1048/4#													
	1048/5#	51,0	54,9	75,4	35,7	51,7	51,5	34,5	37,7	45,1	47,0	47,2	47,7	36,4
	1049/7#													
	1050/5#	64,6	69,5	95,5	45,2	65,5	65,2	43,7	47,8	57,2	59,5	59,7	60,5	46,1
	1050/6#	81,6	87,8	120,6	57,1	82,7	82,4	55,2	60,4	72,2	75,1	75,5	76,4	58,2
	1058/5#	64,6	69,5	95,5	45,2	65,5	65,2	43,7	47,8	57,2	59,5	59,7	60,5	46,1
	1058/6#	81,6	87,8	120,6	57,1	82,7	82,4	55,2	60,4	72,2	75,1	75,5	76,4	58,2
	1058/7#	96,9	104,3	143,2	67,8	98,2	97,9	65,6	71,7	85,7	89,2	89,6	90,7	69,1
	1059/9#													
	1098/9#	170,0	183,0	251,3	119,0	172,3	171,7	115,0	125,8	150,4	156,5	157,2	159,1	121,3
	1099/11#													
1078/11#	272,0	292,8	-	190,4	275,7	274,7	184,0	-	240,6	250,4	251,5	254,6	194,1	
1079/13#														
1079/M42#														
1078/13#	425,0	457,5	-	297,5	430,8	429,3	287,5	-	376,0	391,3	393,0	397,8	303,3	
1078/M42#														
1079/17#														

= S , A6 , A7

Continued

Standard rating conditions according to AHRI Standard 760-2007

Condensing temperature	110 °F	(43,3 °C)	Temperature leaving evaporator	50 °F	(9,9 °C)
Liquid temperature	100 °F	(37,8 °C)	Evaporator superheating	10 °R	(5,5 °K)
Subcooling	10 °R	(5,5 °K)	Suction line temperature	65 °F	(18,3 °C)
Evaporating temperature	40 °F	(4,4 °C)	Suction superheating	15 °R	(8,4 °K)
			Discharge temperature	160 °F	(71,1 °C)

TABLE 4: Refrigerant flow capacity of NC valves [kW]

Operating Principles	Catalogue Number	Suction line												
		R134a	R22	R32	R404A	R407C	R410A	R507	R1234yf	R1234ze	R448A	R449A	R450A	R452A
Direct Acting	1020/2#	-	-	-	-	-	-	-	-	-	-	-	-	-
	1020/3#													
	1028/2#													
	1028/2#.E													
	1028/3#													
	1028/M10#													
Diaphragm Pilot Operated	1064/3#	1,46	2,04	3,40	1,76	1,82	2,64	1,78	1,18	1,14	1,92	1,76	1,27	1,69
	1064/4#													
	1068/3#													
	1068/M10#													
	1068/M12#													
	1068/4#													
	1070/4#	4,00	5,61	9,35	4,84	4,99	7,26	4,91	3,23	3,12	5,28	4,84	3,50	4,64
	1070/5#	4,75	6,66	11,09	5,74	5,92	8,61	5,82	3,84	3,71	6,26	5,74	4,15	5,51
	1078/M12#	4,00	5,61	9,35	4,84	4,99	7,26	4,91	3,23	3,12	5,28	4,84	3,50	4,64
	1078/4#													
	1078/5#	4,75	6,66	11,09	5,74	5,92	8,61	5,82	3,84	3,71	6,26	5,74	4,15	5,51
	1079/7#	6,9	9,7	16,2	8,4	8,6	12,5	8,5	5,6	5,4	9,1	8,4	6,0	8,0
	1090/5#	8,7	12,2	20,4	10,6	10,9	15,8	10,7	7,1	6,8	11,5	10,6	7,6	10,1
	1090/6#	6,9	9,7	16,2	8,4	8,6	12,5	8,5	5,6	5,4	9,1	8,4	6,0	8,0
	1098/5#	8,7	12,2	20,4	10,6	10,9	15,8	10,7	7,1	6,8	11,5	10,6	7,6	10,1
	1098/6#	10,4	14,5	24,2	12,5	12,9	18,8	12,7	8,4	8,1	13,7	12,5	9,1	12,0
	1098/7#	18,2	25,5	42,5	22,0	22,7	33,0	22,3	14,7	14,2	24,0	22,0	15,9	21,1
	1099/9#													
	1078/9#	18,2	25,5	42,5	22,0	22,7	33,0	22,3	14,7	14,2	24,0	22,0	15,9	21,1
1079/11#	18,2	25,5	42,5	22,0	22,7	33,0	22,3	14,7	14,2	24,0	22,0	15,9	21,1	
Piston Pilot Operated	1034/3#	1,82	2,55	4,25	2,20	2,27	3,30	2,23	1,47	1,42	2,40	2,20	1,59	2,11
	1034/4#													
	1038/3#													
	1038/M10#													
	1038/M12#													
	1038/4#													
	1040/4#	4,37	6,12	10,20	5,28	5,45	7,92	5,35	3,53	3,41	5,76	5,28	3,82	5,06
	1040/5#	5,46	7,65	12,75	6,60	6,81	9,90	6,69	4,41	4,26	7,20	6,60	4,77	6,33
	1048/M12#	4,37	6,12	10,20	5,28	5,45	7,92	5,35	3,53	3,41	5,76	5,28	3,82	5,06
	1048/4#													
	1048/5#	5,46	7,65	12,75	6,60	6,81	9,90	6,69	4,41	4,26	7,20	6,60	4,77	6,33
	1049/7#	6,9	9,7	16,2	8,4	8,6	12,5	8,5	5,6	5,4	9,1	8,4	6,0	8,0
	1050/5#	8,7	12,2	20,4	10,6	10,9	15,8	10,7	7,1	6,8	11,5	10,6	7,6	10,1
	1050/6#	6,9	9,7	16,2	8,4	8,6	12,5	8,5	5,6	5,4	9,1	8,4	6,0	8,0
	1058/5#	8,7	12,2	20,4	10,6	10,9	15,8	10,7	7,1	6,8	11,5	10,6	7,6	10,1
	1058/6#	10,4	14,5	24,2	12,5	12,9	18,8	12,7	8,4	8,1	13,7	12,5	9,1	12,0
	1058/7#	18,2	25,5	42,5	22,0	22,7	33,0	22,3	14,7	14,2	24,0	22,0	15,9	21,1
	1059/9#													
	1098/9#	18,2	25,5	42,5	22,0	22,7	33,0	22,3	14,7	14,2	24,0	22,0	15,9	21,1
	1099/11#	18,2	25,5	42,5	22,0	22,7	33,0	22,3	14,7	14,2	24,0	22,0	15,9	21,1
1078/11#	29,1	40,8	-	35,2	36,3	52,8	35,7	-	22,7	38,4	35,2	25,4	33,8	
1079/13#														
1079/M42#														
1078/13#	45,5	63,8	-	55,0	56,8	82,5	55,8	-	35,5	60,0	55,0	39,8	52,8	
1078/M42#														
1079/17#														

= S , A6 , A7

Continued

Standard rating conditions according to AHRI Standard 760-2007

Condensing temperature	110 °F	(43,3 °C)	Temperature leaving evaporator	50 °F	(9,9 °C)
Liquid temperature	100 °F	(37,8 °C)	Evaporator superheating	10 °R	(5,5 °K)
Subcooling	10 °R	(5,5 °K)	Suction line temperature	65 °F	(18,3 °C)
Evaporating temperature	40 °F	(4,4 °C)	Suction superheating	15 °R	(8,4 °K)
			Discharge temperature	160 °F	(71,1 °C)

TABLE 4: Refrigerant flow capacity of NC valves [kW]

Operating Principles	Catalogue Number	Hot Gas line												
		R134a	R22	R32	R404A	R407C	R410A	R507	R1234yf	R1234ze	R448A	R449A	R450A	R452A
Direct Acting	1020/2#	1,49	1,96	3,18	1,68	2,08	2,38	1,67	1,16	1,20	2,07	1,89	1,34	1,75
	1020/3#	1,96	2,58	4,18	2,21	2,74	3,13	2,19	1,53	1,58	2,71	2,48	1,76	2,30
	1028/2#	1,28	1,68	2,72	1,44	1,79	2,04	1,43	1,00	1,03	1,77	1,62	1,15	1,50
	1028/2#.E	1,96	2,58	4,18	2,21	2,74	3,13	2,19	1,53	1,58	2,71	2,48	1,76	2,30
	1028/3#													
	1028/M10#													
1028/M12#														
Diaphragm Pilot Operated	1064/3#	6,8	9,0	14,5	7,7	9,5	10,9	7,6	5,3	5,5	9,4	8,6	6,1	8,0
	1064/4#													
	1068/3#													
	1068/M10#													
	1068/M12#													
	1068/4#													
	1070/4#	18,7	24,6	40,0	21,1	26,2	29,9	21,0	14,6	15,1	26,0	23,7	16,8	22,0
	1070/5#	22,2	29,2	47,4	25,1	31,1	35,5	24,9	17,3	17,9	30,8	28,1	20,0	26,0
	1078/M12#	18,7	24,6	40,0	21,1	26,2	29,9	21,0	14,6	15,1	26,0	23,7	16,8	22,0
	1078/4#													
	1078/5#	22,2	29,2	47,4	25,1	31,1	35,5	24,9	17,3	17,9	30,8	28,1	20,0	26,0
	1079/7#													
	1090/5#	32,3	42,6	69,0	36,5	45,2	51,7	36,3	25,2	26,0	44,8	41,0	29,1	37,9
	1090/6#	40,8	53,8	87,2	46,1	57,1	65,3	45,8	31,9	32,9	56,6	51,7	36,7	47,9
	1098/5#	32,3	42,6	69,0	36,5	45,2	51,7	36,3	25,2	26,0	44,8	41,0	29,1	37,9
	1098/6#	40,8	53,8	87,2	46,1	57,1	65,3	45,8	31,9	32,9	56,6	51,7	36,7	47,9
	1098/7#	48,5	63,8	103,5	54,7	67,8	77,5	54,4	37,8	39,0	67,3	61,4	43,6	56,9
	1099/9#													
	1078/9#	85,0	112,0	181,6	96,0	119,0	136,0	95,4	66,4	68,5	118,0	107,8	76,5	99,8
	1079/11#													
Piston Pilot Operated	1034/3#	8,5	11,2	18,2	9,6	11,9	13,6	9,5	6,6	6,9	11,8	10,8	7,7	10,0
	1034/4#													
	1038/3#													
	1038/M10#													
	1038/M12#													
	1038/4#													
	1040/4#	20,4	26,9	43,6	23,0	28,6	32,6	22,9	15,9	16,4	28,3	25,9	18,4	24,0
	1040/5#	25,5	33,6	54,5	28,8	35,7	40,8	28,6	19,9	20,6	35,4	32,3	23,0	29,9
	1048/M12#	20,4	26,9	43,6	23,0	28,6	32,6	22,9	15,9	16,4	28,3	25,9	18,4	24,0
	1048/4#													
	1048/5#	25,5	33,6	54,5	28,8	35,7	40,8	28,6	19,9	20,6	35,4	32,3	23,0	29,9
	1049/7#													
	1050/5#	32,3	42,6	69,0	36,5	45,2	51,7	36,3	25,2	26,0	44,8	41,0	29,1	37,9
	1050/6#	40,8	53,8	87,2	46,1	57,1	65,3	45,8	31,9	32,9	56,6	51,7	36,7	47,9
	1058/5#	32,3	42,6	69,0	36,5	45,2	51,7	36,3	25,2	26,0	44,8	41,0	29,1	37,9
	1058/6#	40,8	53,8	87,2	46,1	57,1	65,3	45,8	31,9	32,9	56,6	51,7	36,7	47,9
	1058/7#	48,5	63,8	103,5	54,7	67,8	77,5	54,4	37,8	39,0	67,3	61,4	43,6	56,9
	1059/9#													
	1098/9#	85,0	112,0	181,6	96,0	119,0	136,0	95,4	66,4	68,5	118,0	107,8	76,5	99,8
	1099/11#													
1078/11#	136,0	179,2	-	153,6	190,4	217,6	152,6	-	109,6	188,8	172,5	122,4	159,7	
1079/13#														
1079/M42#														
1078/13#	212,5	280,0	-	240,0	297,5	340,0	238,5	-	171,3	295,0	269,5	191,3	249,5	
1078/M42#														
1079/17#														

= S , A6 , A7

Standard rating conditions according to AHRI Standard 760-2007

Condensing temperature	110 °F	(43,3 °C)	Temperature leaving evaporator	50 °F	(9,9 °C)
Liquid temperature	100 °F	(37,8 °C)	Evaporator superheating	10 °R	(5,5 °K)
Subcooling	10 °R	(5,5 °K)	Suction line temperature	65 °F	(18,3 °C)
Evaporating temperature	40 °F	(4,4 °C)	Suction superheating	15 °R	(8,4 °K)
			Discharge temperature	160 °F	(71,1 °C)

www.castel.it



ed. 001-VS-ENG

Castel can accept no responsibility for any errors or changes in the catalogues, handbooks, brochures and other printed material. Castel reserves the right to make changes and improvements to its products without notice. All trademarks mentioned are the property of their respective owners.
The name and Castel logotype are registered trademarks of Castel Srl.
All rights reserved.

Castel Srl - Via Provinciale 2-4 - 20060 Pessano con Bornago - MI