

www.pholod.com.ua

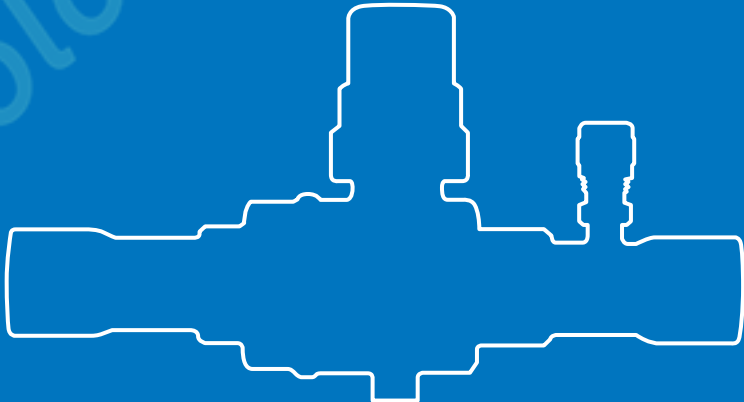

HANDBOOK
VALVES

Ed. 2017



CHAPTER 13

CHECK VALVES

FOR REFRIGERATION PLANTS THAT USE HCFC, HFC OR HFO REFRIGERANTS



APPLICATIONS

The check valves illustrated in this chapter are designed for installation on commercial refrigeration systems and on civil and industrial air conditioning plants that use the following refrigerant fluids:

- HCFC (R22), only valves in series 3122
- HFC (R134a, R404A, R407C, R410A, or R507)
- HFO and HFO/HFC mixtures (R1234ze, R448A, R449A, R450A, or R452A)

belonging to Group 2, as defined in Article 13, Chapter 1, Point (b) of Directive 2014/68/EU, with reference to EC Regulation No. 1272/2008.

Furthermore, the same check valves, up to DN 25, that is models 3122/9, 3124N/9, 3125N/9 can also be installed on systems using the following refrigeration fluids:

- HFC (R32)
- HFO (R1234yf)

classified as A2L in the ASHRAE 34-2013 standard, and belonging to Group 1, as defined in Article 13, Chapter 1, Point (a) of Directive 2014/68/EU, with reference to EC Regulation No. 1272/2008.

For specific applications with refrigerant fluids not listed above, please contact Castel Technical Department.

CONSTRUCTION

These check valves are available in the following two types:

- Valve types 3122, 3124N (standard spring) with a low opening differential; $\Delta p = 0.04$ bar or 0.1 bar.
- Valve types 3125N (reinforced spring) with a high opening differential; $\Delta p = 0.3$ bar. To be used, for example, with compressors in parallel.

The main parts of the check valves are made with the following materials:

- Hot forged brass EN 12420 – CW 617N for body and cover.
- Copper pipe EN 12735-1 – Cu--DHP for solder connections
- Austenitic stainless steel AISI 302 for the spring
- Laminated stainless steel / rubber for outlet seal gaskets for valves in series 3122
- Hydrogenated nitrile (HNBR) for outlet seal gaskets for valves in series 3124N, 3125N
- PTFE for seat gaskets

INSTALLATION

The valves can be installed in any section of a refrigeration system where it is necessary to avoid the consequences from undesirable flow inversion, with respect for the operating limits and the yields indicated in Table 56. Table 55 shows the following functional characteristics of a check valve:

- PS and TS
- Kv factor
- Minimum opening differential pressure at which the valve can open and remain opened.

Before connecting the valve to the pipe, it is advisable to make sure that the refrigerating system is clean. Valves with PTFE gaskets are particularly sensitive to dirt and debris. Furthermore, check that the flow direction in the pipe corresponds to the arrow stamped on the valve body. The brazing of valves with solder connections should be carried out with care, using a low melting point filler material (min. 5% Ag). **Before starting to braze the body, it is necessary to disassemble the valves in series 3122, 3124N, 3125N.** It is important to avoid direct contact between the torch flame and the body, which could be damaged and compromise the proper functioning of the entire valve.

The allowed operating positions are the following:

- 3122, 3124N, 3125N: with the piping axis horizontal and valve cover facing upward or to the side, horizontal. With the piping axis vertical and arrow facing either upward or downward. **Note: valves 3122, 3124N, 3125N cannot be installed with the valve cover facing downward.**

TABLE 55: General characteristics of check valves

Catalogue Number	Connections		Kv Factor [m³/h]	Minimum Opening Pressure Differential [bar]	PS [bar]	TS [°C]		TA [°C]		Risk Category according to PED Recast						
	ODS					min.	max.	min.	max.							
	Ø [in.]	Ø [mm]														
3122/M22	–	22	6,6	0,1	45	– 35	+160	– 35	+50	Art. 4.3						
3122/7	7/8"	–														
3122/M28	–	28	8,8													
3122/9	1.1/8"	–														
3122/11	1.3/8"	35	15,2													
3122/13	1.5/8"	–	25,0													
3122/M42	–	42														
3122/17	2.1/8"	54								40,0						
3124N/M22	–	22	8,1							0,04	45	-40	+150	-40	+50	Art. 4.3
3124N/7	7/8"	–														
3124N/M28	–	28	10,4													
3124N/9	1.1/8"	–														
3124N/11	1.3/8"	35	15,6													
3124N/13	1.5/8"	–	27,0													
3124N/M42	–	42														
3124N/17	2.1/8"	54		39,0												
3125N/M22	–	22	8,1	0,3	45	-40	+150	-40	+50							Art. 4.3
3125N/7	7/8"	–														
3125N/M28	–	28	10,4													
3125N/9	1.1/8"	–														
3125N/11	1.3/8"	35	15,6													
3125N/13	1.5/8"	–	27,0													
3125N/M42	–	42														
3125N/17	2.1/8"	54								39,0						

TABLE 56: Refrigerant flow capacity of check valves [kW]

Catalogue Number	Liquid line													
	R134a	R22	R32	R404A	R407C	R410A	R507	R1234yf	R1234ze	R448A	R449A	R450A	R452A	
3122/M22	–	112,20	120,78	165,86	78,54	113,72	113,32	75,90	83,03	99,26	103,29	103,75	105,01	80,06
3122/7	–													
3122/M28	–	149,60	161,04	221,14	104,72	151,62	151,10	101,20	110,70	132,35	137,72	138,34	140,01	106,74
3122/9	–													
3122/11	–	258,40	278,16	–	180,88	261,90	260,98	174,80	–	228,61	237,88	238,94	241,83	184,38
3122/13	–	425,00	457,50	–	297,50	430,75	429,25	287,50	–	376,00	391,25	393,00	397,75	303,25
3122/M42	–													
3122/17	–	680,00	732,00	–	476,00	689,20	686,80	460,00	–	601,60	626,00	628,80	636,40	485,20
3124N/M22	3125N/M22	137,70	148,23	203,55	96,39	139,56	139,08	93,15	101,90	121,82	126,77	127,33	128,87	98,25
3124N/7	3125N/7													
3124N/M28	3125N/M28	176,80	190,32	261,35	123,76	179,19	178,57	119,60	130,83	156,42	162,76	163,49	165,46	126,15
3124N/9	3125N/9													
3124N/11	3125N/11	265,20	285,48	–	185,64	268,79	267,85	179,40	–	234,62	244,14	245,23	248,20	189,23
3124N/13	3125N/13	459,00	494,10	–	321,30	465,21	463,59	310,50	–	406,08	422,55	424,44	429,57	327,51
3124N/M42	3125N/M42													
3124N/17	3125N/17	663,00	713,70	–	464,10	671,97	669,63	448,50	–	586,56	610,35	613,08	620,49	473,07

Standard rating conditions according to AHRI Standard 760-2007

Condensing temperature	110 °F	(43,3 °C)	Evaporator outlet temperature	50 °F	(9,9 °C)
Liquid temperature	100 °F	(37,8 °C)	Evaporator superheating	10 °R	(5,5 °K)
Subcooling	10 °R	(5,5 °K)	Suction line temperature	65 °F	(18,3 °C)
Evaporating temperature	40 °F	(4,4 °C)	Suction superheating	15 °R	(8,4 °K)
			Discharge temperature	160 °F	(71,1 °C)

Continued

TABLE 56: Refrigerant flow capacity of check valves [kW]

Catalogue Number		Suction line												
		R134a	R22	R32	R404A	R407C	R410A	R507	R1234yf	R1234ze	R448A	R449A	R450A	R452A
3122/M22	–	12,01	16,83	28,05	14,52	14,98	21,78	14,72	9,70	9,37	15,84	14,52	10,49	13,93
3122/7	–													
3122/M28	–	16,02	22,44	37,40	19,36	19,98	29,04	19,62	12,94	12,50	21,12	19,36	13,99	18,57
3122/9	–													
3122/11	–	27,66	38,76		33,44	34,50	50,16	33,90		21,58	36,48	33,44	24,17	32,07
3122/13	–	45,50	63,75		55,00	56,75	82,50	55,75		35,50	60,00	55,00	39,75	52,75
3122/M42	–													
3122/17	–	72,80	102,00		88,00	90,80	132,00	89,20		56,80	96,00	88,00	63,60	84,40
3124N/M22	3125N/M22	14,74	20,66	34,43	17,82	18,39	26,73	18,06	11,91	11,50	19,44	17,82	12,88	17,09
3124N/7	3125N/7													
3124N/M28	3125N/M28	18,93	26,52	44,20	22,88	23,61	34,32	23,19	15,29	14,77	24,96	22,88	16,54	21,94
3124N/9	3125N/9													
3124N/11	3125N/11	28,39	39,78		34,32	35,41	51,48	34,79		22,15	37,44	34,32	24,80	32,92
3124N/13	3125N/13	49,14	68,85		59,40	61,29	89,10	60,21		38,34	64,80	59,40	42,93	56,97
3124N/M42	3125N/M42													
3124N/17	3125N/17	70,98	99,45		85,80	88,53	128,70	86,97		55,38	93,60	85,80	62,01	82,29

Continued

TABLE 56: Refrigerant flow capacity of check valves [kW]

Catalogue Number		Hot Gas line												
		R134a	R22	R32	R404A	R407C	R410A	R507	R1234yf	R1234ze	R448A	R449A	R450A	R452A
3122/M22	–	56,10	73,92	119,86	63,36	78,54	89,76	62,96	43,82	45,21	77,88	71,15	50,49	65,87
3122/7	–													
3122/M28	–	74,80	98,56	159,81	84,48	104,72	119,68	83,95	58,43	60,28	103,84	94,86	67,32	87,82
3122/9	–													
3122/11	–	129,20	170,24		145,92	180,88	206,72	145,01		104,12	179,36	163,86	116,28	151,70
3122/13	–	212,50	280,00		240,00	297,50	340,00	238,50		171,25	295,00	269,50	191,25	249,50
3122/M42	–													
3122/17	–	340,00	448,00		384,00	476,00	544,00	381,60		274,00	472,00	431,20	306,00	399,20
3124N/M22	3125N/M22	68,85	90,72	147,10	77,76	96,39	110,16	77,27	53,78	55,49	95,58	87,32	61,97	80,84
3124N/7	3125N/7													
3124N/M28	3125N/M28	88,40	116,48	188,86	99,84	123,76	141,44	99,22	69,06	71,24	122,72	112,11	79,56	103,79
3124N/9	3125N/9													
3124N/11	3125N/11	132,60	174,72		149,76	185,64	212,16	148,82		106,86	184,08	168,17	119,34	155,69
3124N/13	3125N/13	229,50	302,40		259,20	321,30	367,20	257,58		184,95	318,60	291,06	206,55	269,46
3124N/M42	3125N/M42													
3124N/17	3125N/17	331,50	436,80		374,40	464,10	530,40	372,06		267,15	460,20	420,42	298,35	389,22

Standard rating conditions according to AHRI Standard 760-2007

Condensing temperature	110 °F	(43,3 °C)	Evaporator outlet temperature	50 °F	(9,9 °C)
Liquid temperature	100 °F	(37,8 °C)	Evaporator superheating	10 °R	(5,5 °K)
Subcooling	10 °R	(5,5 °K)	Suction line temperature	65 °F	(18,3 °C)
Evaporating temperature	40 °F	(4,4 °C)	Suction superheating	15 °R	(8,4 °K)
			Discharge temperature	160 °F	(71,1 °C)

TABLE 57: Dimensions and weights of check valves

Catalogue Number		Dimensions [mm]				Weight [g]
		H	H ₁	L	D	
3122/M22	-	84,5	28,5	100	60	1190
3122/7	-					
3122/M28	-					
3122/9	-					
3122/11	-	101,5	34	118	68	1557
3122/13	-	125,5	37	141	88	2990
3122/M42	-					
3122/17	-	142	42,5	173	104	4665
3124N/M22	3125N/M22	96	24	80	50	855
3124N/7	3125N/7					
3124N/M28	3125N/M28					867
3124N/9	3125N/9					
3124N/11	3125N/11	115	29	92	56	1130
3124N/13	3125N/13	148	36	121	67	
3124N/M42	3125N/M42					
3124N/17	3125N/17	167	44	157	79	

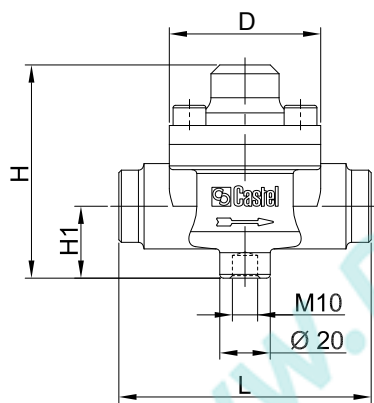

3122

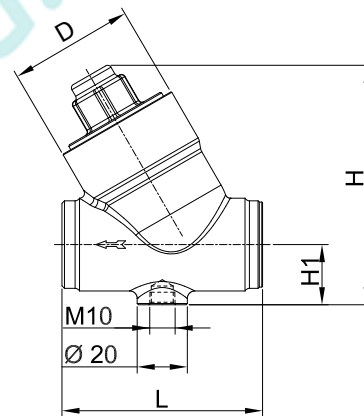

3124N
3125N

www.castel.it



ed. 002-VR-ENG

Castel can accept no responsibility for any errors or changes in the catalogues, handbooks, brochures and other printed material. Castel reserves the right to make changes and improvements to its products without notice. All trademarks mentioned are the property of their respective owners.
The name and Castel logotype are registered trademarks of Castel Srl.
All rights reserved.

Castel Srl - Via Provinciale 2-4 - 20060 Pessano con Bornago - MI