

www.pholod.com.ua

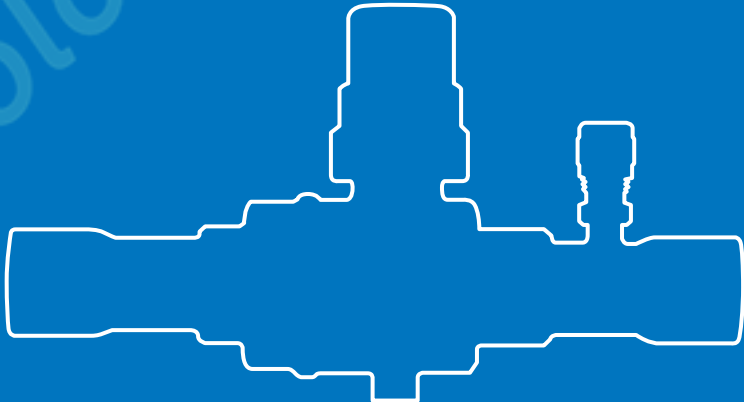

HANDBOOK
VALVES

Ed. 2017



CHAPTER 12 ■ HERMETIC CHECK VALVES

FOR REFRIGERATION PLANTS THAT USE HCFC, HFC, HFO, OR HC REFRIGERANTS



APPLICATIONS

The check valves illustrated in this chapter are designed for installation on commercial refrigeration systems and on civil and industrial air conditioning plants that use the following refrigerant fluids:

- HCFC (R22)
- HFC (R134a, R404A, R407C, R410A, or R507)
- HFO and HFO/HFC mixtures (R1234ze, R448A, R449A, R450A, or R452A)

belonging to Group 2, as defined in Article 13, Chapter 1, Point (b) of Directive 2014/68/EU, with reference to EC Regulation No. 1272/2008.

Furthermore, the same check valves, up to DN 25, that is models 3144W/9, 3145W/9, 3184W/9, 3185W/9 can also be installed on systems using the following:

- HFC (R32)
- HFO (R1234yf)
- HC (R290, R600, or R600a)

belonging to Group 1, as defined in Article 13, Chapter 1, Point (a) of Directive 2014/68/EU, with reference to EC Regulation No. 1272/2008.

For specific applications with refrigerant fluids not listed above, please contact Castel Technical Department.

CONSTRUCTION

These check valves are available in the following two types:

- Valve types 3112W, 3132W, 3144W, 3184W (standard spring) with a low opening differential; $\Delta p = 0.04$ bar.
- Valve types 3113W, 3133W, 3145W, 3185W (reinforced spring) with a high opening differential; $\Delta p = 0.3$ bar. To be used, for example, with compressors in parallel.

Valves in series 3112W, 3113W, 3132W, 3133W, 3144W, 3145W, 3184W, 3185W are equipped with laser welds between the body and the cover to ensure that the product is sealed hermetically. The main parts of the check valves are made with the following materials:

- Brass bar EN 12164 – CW 614N for body and cover of valves in series 3112W, 3113W, 3132W, and 3133W.
- Hot forged brass EN 12420 – CW 617N for body and cover of valves in series 3144W, 3145W, 3184W, and 3185W.
- Copper pipe EN 12735-1 – Cu--DHP for solder connections
- Austenitic stainless steel AISI 302 for the spring
- Laminated glass fibre fabric and PTFE for gasket seals of valves in series 3112W, 3113W, 3132W, and 3133W.
- PTFE for gasket seals of valves in series 3144W, 3145W, 3184W, and 3185W.

INSTALLATION

The valves can be installed in any section of a refrigeration system where it is necessary to avoid the consequences from undesirable flow inversion, with respect for the operating limits and the capacities indicated in Table 53. Table 52 shows the following functional characteristics of a check valve:

- PS and TS
- Kv factor
- Minimum opening differential pressure at which the valve can open and remain opened.

Before connecting the valve to the pipe, it is advisable to make sure that the refrigerating system is clean. Valves with laminated fibreglass and PTFE gaskets are particularly sensitive to dirt and debris. Furthermore, check that the flow direction in the pipe corresponds to the arrow stamped on the valve body.

The brazing of valves with solder connections should be carried out with care, using a low melting point filler material (min. 5% Ag). It is not necessary to disassemble the valves before brazing, but it is important to avoid direct contact between the torch flame and the valve body, which could be damaged and compromise the proper functioning of the valve.

The allowed operating positions are the following:

- 3144W, 3145W: with the piping axis horizontal and valve cover facing upward or to the side, horizontal. With the piping axis vertical and arrow facing either upward or downward. **Note: valves 3144W, 3145W cannot be installed with the valve cover facing downward.**
- 3184W, 3185W: with inlet pipe facing downward and valve cover facing upward. With inlet pipe horizontal and outlet pipe vertical or horizontal. **Note: valves 3184W, and 3185W cannot be installed with the valve input facing upward and the valve cover facing downward.**

Valves 3112W, 3113W, 3132W, 3133W can be installed in any working position.

CERTIFICATIONS

The American certification authority Underwriters Laboratories Inc. has approved the check valves in series 3112W, 3113W, 3132W, 3133W, 3144W, 3145W, 3184W, 3185W. These valves are certified **UL Listed** for the USA with file SA33319, in compliance with American standard UL 207.

TABLE 52: General characteristics of hermetic check valves, UL approved

Catalogue Number	Connections			Kv Factor [m³/h]	Minimum Opening Pressure Differential [bar]	PS [bar]	TS [°C]		TA [°C]		Risk Category according to PED Recast
	SAE Flare	ODS					min.	max.	min.	max.	
		Ø [in.]	Ø [mm]								
3112W/2	1/4"	-	-	0,5	0,04	45 (1)	-40	+150	-40	+50	Art. 4.3
3112W/3	3/8"			1,5							
3112W/4	1/2"			1,8							
3112W/5	5/8"			3,3							
3112W/6	3/4"			5,0							
3113W/2	1/4"	-	-	0,5	0,30	45 (1)	-40	+150	-40	+50	Art. 4.3
3113W/3	3/8"			1,5							
3113W/4	1/2"			1,8							
3113W/5	5/8"			3,3							
3113W/6	3/4"			5,0							
3132W/2	-	1/4"	-	0,5	0,04	45 (1)	-40	+150	-40	+50	Art. 4.3
3132W/3		3/8"	-	1,5							
3132W/M10		-	10	1,8							
3132W/M12		-	12								
3132W/4		1/2"	-	3,3							
3132W/5		5/8"	16	5,0							
3132W/M18		-	18								
3132W/6		3/4"	-								
3132W/7		7/8"	22								
3133W/2	-	1/4"	-	0,5	0,30	45 (1)	-40	+150	-40	+50	Art. 4.3
3133W/3		3/8"	-	1,5							
3133W/M10		-	10	1,8							
3133W/M12		-	12								
3133W/4		1/2"	-	3,3							
3133W/5		5/8"	16	5,0							
3133W/M18		-	18								
3133W/6		3/4"	-								
3133W/7		7/8"	22								

(1) : MWP = 600 psi according to UL approval

Continued

TABLE 52: General characteristics of hermetic check valves, UL approved

Catalogue Number	Connections		Kv Factor [m ³ /h]	Minimum Opening Pressure Differential [bar]	PS [bar]	TS [°C]		TA [°C]		Risk Category according to PED Recast	
	SAE Flare	ODS				min.	max.	min.	max.		
		Ø [in.]									Ø [mm]
3144W/7	-	7/8"	22	8,1	0,04	45 (1)	- 40	+150	- 40	+50	Art. 4.3
3144W/M28		-	28	10,4							
3144W/9		1.1/8"	-	15,6							
3144W/11		1.3/8"	35	27,0							
3144W/13		1.5/8"	-	39,0							
3144W/M42		-	42								
3144W/17		2.1/8"	54								
3144W/21		2.5/8"	-								
3144W/25		3.1/8"	-								
3145W/7	-	7/8"	22	8,1	0,3	45 (1)	- 40	+150	- 40	+50	Art. 4.3
3145W/M28		-	28	10,4							
3145W/9		1.1/8"	-	15,6							
3145W/11		1.3/8"	35	27,0							
3145W/13		1.5/8"	-	39,0							
3145W/M42		-	42								
3145W/17		2.1/8"	54								
3145W/21		2.5/8"	-								
3145W/25		3.1/8"	-								
3184W/7	-	7/8"	22	9,0	0,04	45 (1)	- 40	+150	- 40	+50	Art. 4.3
3184W/M28		-	28	19,0							
3184W/9		1.1/8"	-	29,0							
3184W/11		1.3/8"	35								
3185W/7	-	7/8"	22	9,0	0,3	45 (1)	- 40	+150	- 40	+50	Art. 4.3
3185W/M28		-	28	19,0							
3185W/9		1.1/8"	-	29,0							
3185W/11		1.3/8"	35								

(1) : MWP = 600 psi according to UL approval

TABLE 53: Refrigerant flow capacity of hermetic check valves [kW]

Catalogue Number		Liquid line															
		R134a	R22	R32	R404A	R407C	R410A	R507	R1234yf	R1234ze	R448A	R449A	R450A	R452A	R290	R600	R600a
3112W/2	3113W/2	8,50	9,15	12,57	5,95	8,62	8,59	5,75	6,29	7,52	7,83	7,86	7,96	6,07	10,19	11,95	10,60
3112W/3	3113W/3	25,50	27,45	37,70	17,85	25,85	25,76	17,25	18,87	22,56	23,48	23,58	23,87	18,20	30,57	35,85	31,80
3112W/4	3113W/4	30,60	32,94	45,23	21,42	31,01	30,91	20,70	22,64	27,07	28,17	28,30	28,64	21,83	36,68	43,02	38,16
3112W/5	3113W/5	56,10	60,39	82,93	39,27	56,86	56,66	37,95	41,51	49,63	51,65	51,88	52,50	40,03	67,25	78,87	69,96
3112W/6	3113W/6	85,00	91,50	125,65	59,50	86,15	85,85	57,50	62,90	75,20	78,25	78,60	79,55	60,65	101,90	119,50	106,00
3132W/2	3133W/2	8,50	9,15	12,57	5,95	8,62	8,59	5,75	6,29	7,52	7,83	7,86	7,96	6,07	10,19	11,95	10,60
3132W/3	3133W/3	25,50	27,45	37,70	17,85	25,85	25,76	17,25	18,87	22,56	23,48	23,58	23,87	18,20	30,57	35,85	31,80
3132W/M10	3133W/M10																
3132W/M12	3133W/M12	30,60	32,94	45,23	21,42	31,01	30,91	20,70	22,64	27,07	28,17	28,30	28,64	21,83	36,68	43,02	38,16
3132W/4	3133W/4																
3132W/5	3133W/5	56,10	60,39	82,93	39,27	56,86	56,66	37,95	41,51	49,63	51,65	51,88	52,50	40,03	67,25	78,87	69,96
3132W/M18	3133W/M18	85,00	91,50	125,65	59,50	86,15	85,85	57,50	62,90	75,20	78,25	78,60	79,55	60,65	101,90	119,50	106,00
3132W/6	3133W/6																
3132W/7	3133W/7																
3144W/7	3145W/7	137,70	148,23	203,55	96,39	139,56	139,08	93,15	101,90	121,82	126,77	127,33	128,87	98,25	165,08	193,59	171,72
3144W/M28	3145W/M28	176,80	190,32	261,35	123,76	179,19	178,57	119,60	130,83	156,42	162,76	163,49	165,46	126,15	211,95	248,56	220,48
3144W/9	3145W/9																
3144W/11	3145W/11	265,20	285,48		185,64	268,79	267,85	179,40		234,62	244,14	245,23	248,20	189,23			
3144W/13	3145W/13	459,00	494,10		321,30	465,21	463,59	310,50		406,08	422,55	424,44	429,57	327,51			
3144W/M42	3145W/M42																
3144W/17	3145W/17																
3144W/21	3145W/21	663,00	713,70		464,10	671,97	669,63	448,50		586,56	610,35	613,08	620,49	473,07			
3144W/25	3145W/25																
3184W/7	3185W/7	153,00	164,70	226,17	107,10	155,07	154,53	103,50	113,22	135,36	140,85	141,48	143,19	109,17	183,42	215,10	190,80
3184W/M28	3185W/M28	323,00	347,70	477,47	226,10	327,37	326,23	218,50	239,02	285,76	297,35	298,68	302,29	230,47	387,22	454,10	402,80
3184W/9	3185W/9																
3184W/11	3185W/11	493,00	530,70		345,10	499,67	497,93	333,50		436,16	453,85	455,88	461,39	351,77			

Standard rating conditions according to AHRI Standard 760-2007

Continued

Condensing temperature	110 °F	(43,3 °C)	Evaporator outlet temperature	50 °F	(9,9 °C)
Liquid temperature	100 °F	(37,8 °C)	Evaporator superheating	10 °R	(5,5 °K)
Subcooling	10 °R	(5,5 °K)	Suction line temperature	65 °F	(18,3 °C)
Evaporating temperature	40 °F	(4,4 °C)	Suction superheating	15 °R	(8,4 °K)
			Discharge temperature	160 °F	(71,1 °C)

TABLE 53: Refrigerant flow capacity of hermetic check valves [kW]

Catalogue Number		Suction line															
		R134a	R22	R32	R404A	R407C	R410A	R507	R1234yf	R1234ze	R448A	R449A	R450A	R452A	R290	R600	R600a
3112W/2	3113W/2	0,91	1,28	2,13	1,10	1,14	1,65	1,12	0,74	0,71	1,20	1,10	0,80	1,06	1,53	0,65	0,79
3112W/3	3113W/3	2,73	3,83	6,38	3,30	3,41	4,95	3,35	2,21	2,13	3,60	3,30	2,39	3,17	4,58	1,94	2,37
3112W/4	3113W/4	3,28	4,59	7,65	3,96	4,09	5,94	4,01	2,65	2,56	4,32	3,96	2,86	3,80	5,49	2,32	2,84
3112W/5	3113W/5	6,01	8,42	14,03	7,26	7,49	10,89	7,36	4,85	4,69	7,92	7,26	5,25	6,96	10,07	4,26	5,21
3112W/6	3113W/6	9,10	12,75	21,25	11,00	11,35	16,50	11,15	7,35	7,10	12,00	11,00	7,95	10,55	15,25	6,45	7,90
3132W/2	3133W/2	0,91	1,28	2,13	1,10	1,14	1,65	1,12	0,74	0,71	1,20	1,10	0,80	1,06	1,53	0,65	0,79
3132W/3	3133W/3	2,73	3,83	6,38	3,30	3,41	4,95	3,35	2,21	2,13	3,60	3,30	2,39	3,17	4,58	1,94	2,37
3132W/M10	3133W/M10																
3132W/M12	3133W/M12	3,28	4,59	7,65	3,96	4,09	5,94	4,01	2,65	2,56	4,32	3,96	2,86	3,80	5,49	2,32	2,84
3132W/4	3133W/4																
3132W/5	3133W/5	6,01	8,42	14,03	7,26	7,49	10,89	7,36	4,85	4,69	7,92	7,26	5,25	6,96	10,07	4,26	5,21
3132W/M18	3133W/M18	9,10	12,75	21,25	11,00	11,35	16,50	11,15	7,35	7,10	12,00	11,00	7,95	10,55	15,25	6,45	7,90
3132W/6	3133W/6																
3132W/7	3133W/7																
3144W/7	3145W/7	14,74	20,66	34,43	17,82	18,39	26,73	18,06	11,91	11,50	19,44	17,82	12,88	17,09	24,71	10,45	12,80
3144W/M28	3145W/M28	18,93	26,52	44,20	22,88	23,61	34,32	23,19	15,29	14,77	24,96	22,88	16,54	21,94	31,72	13,42	16,43
3144W/9	3145W/9																
3144W/11	3145W/11	28,39	39,78		34,32	35,41	51,48	34,79		22,15	37,44	34,32	24,80	32,92			
3144W/13	3145W/13	49,14	68,85		59,40	61,29	89,10	60,21		38,34	64,80	59,40	42,93	56,97			
3144W/M42	3145W/M42																
3144W/17	3145W/17																
3144W/21	3145W/21	70,98	99,45		85,80	88,53	128,70	86,97		55,38	93,60	85,80	62,01	82,29			
3144W/25	3145W/25																
3184W/7	3185W/7	16,38	22,95	38,25	19,80	20,43	29,70	20,07	13,23	12,78	21,60	19,80	14,31	18,99	27,45	11,61	14,22
3184W/M28	3185W/M28	34,58	48,45	80,75	41,80	43,13	62,70	42,37	27,93	26,98	45,60	41,80	30,21	40,09	57,95	24,51	30,02
3184W/9	3185W/9																
3184W/11	3185W/11	52,78	73,95		63,80	65,83	95,70	64,67		41,18	69,60	63,80	46,11	61,19			

Standard rating conditions according to AHRI Standard 760-2007

Continued

Condensing temperature	110 °F	(43,3 °C)	Evaporator outlet temperature	50 °F	(9,9 °C)
Liquid temperature	100 °F	(37,8 °C)	Evaporator superheating	10 °R	(5,5 °K)
Subcooling	10 °R	(5,5 °K)	Suction line temperature	65 °F	(18,3 °C)
Evaporating temperature	40 °F	(4,4 °C)	Suction superheating	15 °R	(8,4 °K)
			Discharge temperature	160 °F	(71,1 °C)

TABLE 53: Refrigerant flow capacity of hermetic check valves [kW]

Catalogue Number		Hot Gas line															
		R134a	R22	R32	R404A	R407C	R410A	R507	R1234yf	R1234ze	R448A	R449A	R450A	R452A	R290	R600	R600a
3112W/2	3113W/2	4,25	5,60	9,08	4,80	5,95	6,80	4,77	3,32	3,43	5,90	5,39	3,83	4,99	6,38	3,23	3,72
3112W/3	3113W/3	12,75	16,80	27,24	14,40	17,85	20,40	14,31	9,96	10,28	17,70	16,17	11,48	14,97	19,14	9,69	11,16
3112W/4	3113W/4	15,30	20,16	32,69	17,28	21,42	24,48	17,17	11,95	12,33	21,24	19,40	13,77	17,96	22,97	11,63	13,39
3112W/5	3113W/5	28,05	36,96	59,93	31,68	39,27	44,88	31,48	21,91	22,61	38,94	35,57	25,25	32,93	42,11	21,32	24,55
3112W/6	3113W/6	42,50	56,00	90,80	48,00	59,50	68,00	47,70	33,20	34,25	59,00	53,90	38,25	49,90	63,80	32,30	37,20
3132W/2	3133W/2	4,25	5,60	9,08	4,80	5,95	6,80	4,77	3,32	3,43	5,90	5,39	3,83	4,99	6,38	3,23	3,72
3132W/3	3133W/3	12,75	16,80	27,24	14,40	17,85	20,40	14,31	9,96	10,28	17,70	16,17	11,48	14,97	19,14	9,69	11,16
3132W/M10	3133W/M10																
3132W/M12	3133W/M12	15,30	20,16	32,69	17,28	21,42	24,48	17,17	11,95	12,33	21,24	19,40	13,77	17,96	22,97	11,63	13,39
3132W/4	3133W/4																
3132W/5	3133W/5	28,05	36,96	59,93	31,68	39,27	44,88	31,48	21,91	22,61	38,94	35,57	25,25	32,93	42,11	21,32	24,55
3132W/M18	3133W/M18	42,50	56,00	90,80	48,00	59,50	68,00	47,70	33,20	34,25	59,00	53,90	38,25	49,90	63,80	32,30	37,20
3132W/6	3133W/6																
3132W/7	3133W/7																
3144W/7	3145W/7	68,85	90,72	147,10	77,76	96,39	110,16	77,27	53,78	55,49	95,58	87,32	61,97	80,84	103,36	52,33	60,26
3144W/M28	3145W/M28	88,40	116,48	188,86	99,84	123,76	141,44	99,22	69,06	71,24	122,72	112,11	79,56	103,79	132,70	67,18	77,38
3144W/9	3145W/9																
3144W/11	3145W/11	132,60	174,72		149,76	185,64	212,16	148,82		106,86	184,08	168,17	119,34	155,69			
3144W/13	3145W/13	229,50	302,40		259,20	321,30	367,20	257,58		184,95	318,60	291,06	206,55	269,46			
3144W/M42	3145W/M42																
3144W/17	3145W/17																
3144W/21	3145W/21	331,50	436,80		374,40	464,10	530,40	372,06		267,15	460,20	420,42	298,35	389,22			
3144W/25	3145W/25																
3184W/7	3185W/7	76,50	100,80	163,44	86,40	107,10	122,40	85,86	59,76	61,65	106,20	97,02	68,85	89,82	114,84	58,14	66,96
3184W/M28	3185W/M28	161,50	212,80	345,04	182,40	226,10	258,40	181,26	126,16	130,15	224,20	204,82	145,35	189,62	242,44	122,74	141,36
3184W/9	3185W/9																
3184W/11	3185W/11	246,50	324,80		278,40	345,10	394,40	276,66		198,65	342,20	312,62	221,85	289,42			

Standard rating conditions according to AHRI Standard 760-2007

Condensing temperature	110 °F	(43,3 °C)	Evaporator outlet temperature	50 °F	(9,9 °C)
Liquid temperature	100 °F	(37,8 °C)	Evaporator superheating	10 °R	(5,5 °K)
Subcooling	10 °R	(5,5 °K)	Suction line temperature	65 °F	(18,3 °C)
Evaporating temperature	40 °F	(4,4 °C)	Suction superheating	15 °R	(8,4 °K)
			Discharge temperature	160 °F	(71,1 °C)

TABLE 54: Dimensions and weights of hermetic check valves

Catalogue Number		Dimensions [mm]						Weight [g]				
		L	L ₁	D	H	H ₁	Ch					
3112W/2	3113W/2	58	-	18	-	-	16	60				
3112W/3	3113W/3	70		22			20	100				
3112W/4	3113W/4	75		24			22	132				
3112W/5	3113W/5	87		29			26	204				
3112W/6	3113W/6	100		35			32	330				
3132W/2	3133W/2	93	-	18	-	-	-	65				
3132W/3	3133W/3	108		22				120				
3132W/M10	3133W/M10											
3132W/M12	3133W/M12	133		24				157				
3132W/4	3133W/4											
3132W/5	3133W/5	140		29				220				
3132W/M18	3133W/M18	165		35				-	-	-	304	
3132W/6	3133W/6											
3132W/7	3133W/7											
3144W/7	3145W/7	170		-				50	96	24	-	1055
3144W/M28	3145W/M28	201	56		115	29	-					1062
3144W/9	3145W/9											
3144W/11	3145W/11	232	67		148	36	-	1300				
3144W/13	3145W/13	255						79	167	44	-	
3144W/M42	3145W/M42											
3144W/17	3145W/17	285						-	-	-	-	
3144W/21	3145W/21											
3144W/25	3145W/25	329										
3184W/7	3185W/7	111	88		45	146	94	-	600			
3184W/M28	3185W/M28	149	123	51	196	141	1010					
3184W/9	3185W/9											
3184W/11	3185W/11	151		56	204		1300					

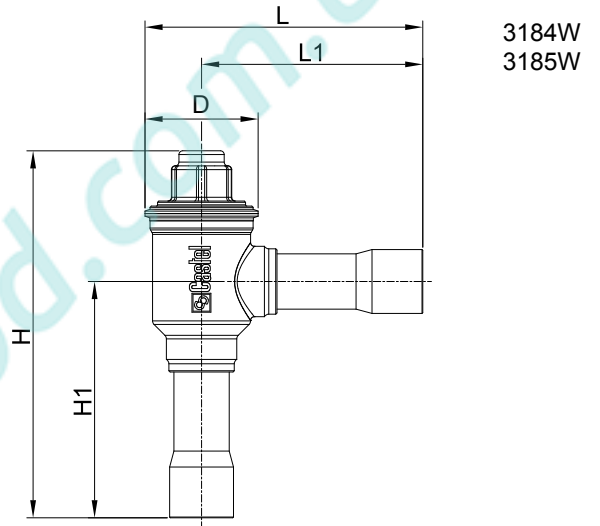
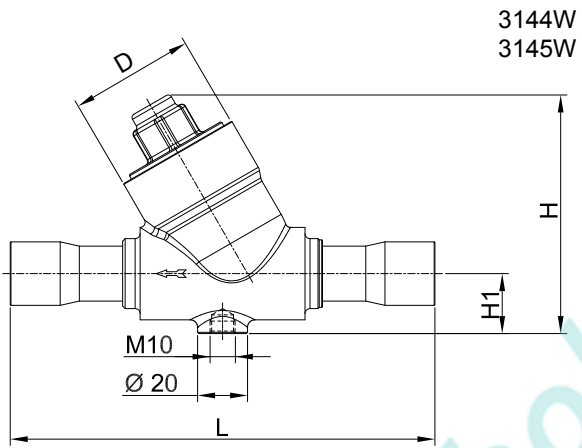
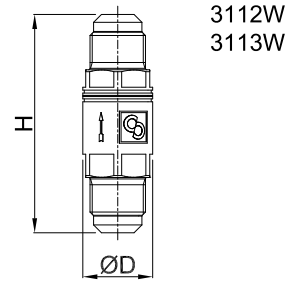
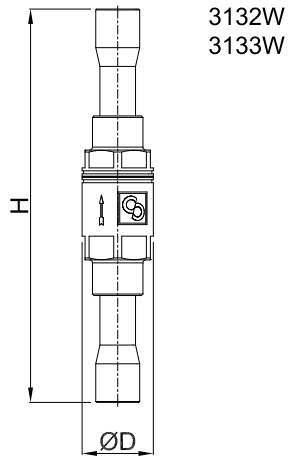

www.castel.it



ed. 002-VR-ENG

Castel can accept no responsibility for any errors or changes in the catalogues, handbooks, brochures and other printed material. Castel reserves the right to make changes and improvements to its products without notice. All trademarks mentioned are the property of their respective owners.
The name and Castel logotype are registered trademarks of Castel Srl.
All rights reserved.

Castel Srl - Via Provinciale 2-4 - 20060 Pessano con Bornago - MI