

GEA Bock FK50

Assembly instructions

09704-01.2018-Gb

Translation of the original instructions

FK50/460 N
FK50/460 K
FK50/460 TK

FK50/555 N
FK50/555 K
FK50/555 TK

FK50/660 N
FK50/660 K
FK50/660 TK

FK50/775 N
FK50/775 K
FK50/775 TK

FK50/830 N
FK50/830 K

FK50/980 N
FK50/980 K

FKX50/460 N
FKX50/460 K
FKX50/460 TK

FKX50/555 N
FKX50/555 K
FKX50/555 TK

FKX50/660 N
FKX50/660 K
FKX50/660 TK

FKX50/775 N
FKX50/775 K
FKX50/775 TK

FKX50/830 N
FKX50/830 K

FKX50/980 N
FKX50/980 K



engineering for
a better world

gea.com

About these instructions

Read these instructions before assembly and before using the compressor. This will avoid misunderstandings and prevent damage. Improper assembly and use of the compressor can lead to serious or fatal injury.

Observe the safety instructions contained in these instructions.

These instructions must be passed onto the end customer along with the unit in which the compressor is installed.

Manufacturer

GEA Bock GmbH
72636 Frickenhausen

Contact

GEA Bock GmbH
Benzstraße 7
72636 Frickenhausen
Germany

Telephone +49 7022 9454 0
Fax +49 7022 9454 137
info@gea.com
www.gea.com

GB

Contents

Page

1	Safety	4
1.1	Identification of safety instructions	
1.2	Qualifications required of personnel	
1.3	General safety instructions	
1.4	Intended use	
2	Product description	6
2.1	Brief description	
2.2	Name plate	
2.3	Type key	
3	Areas of application	8
3.1	Refrigerants	
3.2	Oil charge	
3.3	Limits of application	
3.4	N and K versions	
3.4.1	Limits of application R134a	
3.4.2	Limits of application R407C	
3.5	TK version	
3.5.1	Limits of application R404A/R507	
3.5.2	Limits of application R22	
4	Compressor assembly	11
4.1	Setting up	
4.2	Maximum permissible inclination	
4.3	V-belt drive	
4.4	Main bearing load	
4.5	Electromagnetic clutch assembly	
4.6	Pipe connections	
4.7	Pipes	
4.8	Operating the shut-off valves	
4.9	Operating mode of the lockable service connections	
4.10	Suction pipe filter	
5	Commissioning	15
5.1	Preparations for start-up	
5.2	Pressure strength test	
5.3	Leak test	
5.4	Evacuation	
5.5	Refrigerant charge	
5.6	Oil level check	
5.7	Shaft seal	
5.8	Avoiding liquid shocks	
6	Maintenance	18
6.1	Preparation	
6.2	Work to be carried out	
6.3	Shaft seal, emptying the oil reservoir	
6.4	Recommended spare parts	
6.5	Integrated decompression valves	
6.6	Extract from the lubricants table	
6.7	Decommissioning	
7	Accessories	20
7.1	Capacity regulator	
7.2	Thermi protection thermostat	
8	Technical Data	21
9	Dimensions and Connections	22
10	Installation certificate	24
11	Service	25

GB

1| Safety

1.1 Identification of safety instructions:



DANGER

Indicates a dangerous situation which, if not avoided, will cause immediate fatal or serious injury.



WARNING

Indicates a dangerous situation which, if not avoided, may cause fatal or serious injury.



CAUTION

Indicates a dangerous situation which, if not avoided, may cause fairly severe or minor injury.



ATTENTION

Indicates a situation which, if not avoided, may cause property damage.



INFO

Important information or tips on simplifying work.

GB

1.2 Qualifications required of personnel



WARNING

Inadequately qualified personnel poses the risk of accidents, the consequence being serious or fatal injury. Work on compressors is therefore reserved for personnel which is qualified to work on pressurized refrigerant systems:

- For example, a refrigeration technician, refrigeration mechatronic engineer. As well as professions with comparable training, which enables personnel to assemble, install, maintain and repair refrigeration and air-conditioning systems. Personnel must be capable of assessing the work to be carried out and recognising any potential dangers.

1| Safety

1.3 General safety instructions



WARNING

Risk of accidents.

Refrigerating compressors are pressurised machines and as such call for heightened caution and care in handling.

The maximum permissible overpressure must not be exceeded, even for testing purposes.

Risk of burns!

- Depending on the operating conditions, surface temperatures of over 60°C on the discharge side or below 0°C on the suction side can be reached.

- Avoid contact with refrigerant necessarily.

Contact with refrigerant can cause severe burns and skin damage.

1.4 Intended use

These assembly instructions describe the standard version of the FK50 manufactured by GEA. The compressor is intended for use in refrigeration systems in compliance with the limits of application. Only the refrigerant specified in these instructions may be used.

Any other use of the compressor is prohibited!

The GEA refrigerating compressor named in the title is intended for installation in a machine (within the EU according to the EU Directives 2006/42/EC Machinery Directive and 2014/68/EU Pressure Equipment Directive).

Commissioning is permissible only if the compressor has been installed in accordance with these assembly instructions and the entire system into which it is integrated has been inspected and approved in accordance with legal regulations.

GB

2| Product description

2.1 Brief description

Three different designs are available for various ranges of application:

- > for air-conditioning **the K Design**
- > for air-conditioning or normal cooling **the N Design**
- > for deep freezing **the TK Design**

The differences lie mainly in the valve plate tooling which is adapted to each application range where operational safety and efficiency are concerned.

- Compact six cylinder compressor in W design.
- Six capacity ranges.
- Lightweight aluminum design.
- Lubricating oil pump with oil pressure relief valve independent of rotational direction.
- Variable arrangement of the shut-off valves.

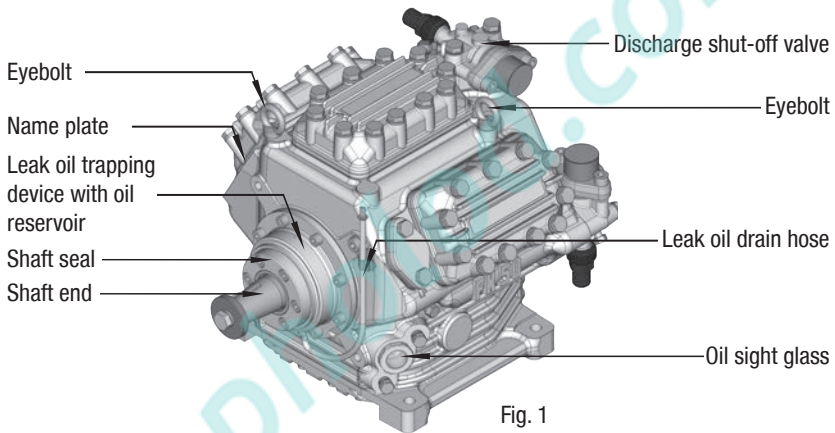

Fig. 1

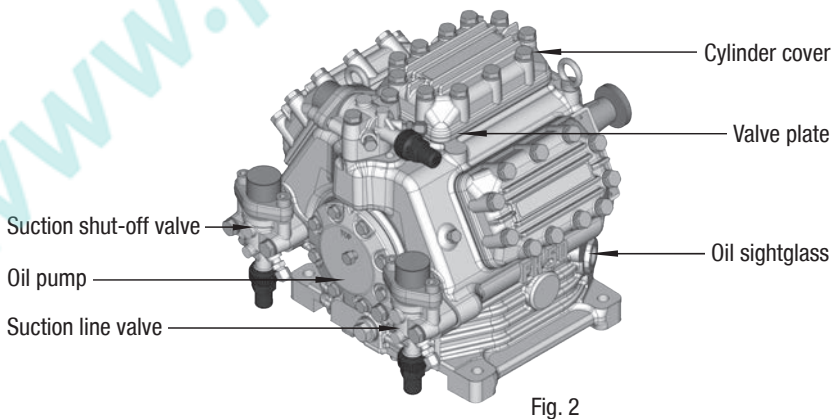

Fig. 2

Dimension and connection values can be found in Chapter 9

2| Product description

2.2 Name plate (example)

Fig. 3

1	Type designation	4	Machine number
2	Displacement at 1450 rpm	5	Factory-filled oil type
3	LP: Max. permissible operating pressure (g) Low pressure side HP: Max. permissible operating pressure (g) High pressure side	Observe the limits of application diagrams!	

2.3 Type key (example)

FK X 50/ 775 N

- FK — Series
- X — Ester oil charging ²⁾
- 50 — Size
- 775 — Swept volume
- N — Designs ¹⁾

¹⁾ K - specially for air-conditioning

N - specially for air-conditioning or normal cooling

TK - specially for deep freezing

²⁾ X - Ester oil charging (HFC refrigerant, e.g. R134a, R407C)

GB

3| Areas of application

3.1 Refrigerants

- HFKW / HFC: R134a, R404A/R507, R407C
- (H)FCKW / (H)CFC: R22

3.2 Oil charge

- The compressors are factory-filled with the following oil type:
 - for R134a, R404A/R507, R407C FUCHS Reniso Triton SE 55
 - for R22 FUCHS Reniso SP 46

Compressors with ester oil charge (FUCHS Reniso Triton SE 55) are marked with an X in the type designation (e.g. FKX50/775 N).



INFO

For recharging, we recommend the above oil types. Alternatives are: see lubricants table, Chapter 6.6.

3.3 Limits of application



ATTENTION

Compressor operation is possible within the limits of application shown in the diagrams. Please note the significance of the shaded areas. The limits of application must be observed. Thresholds should not be selected as design or continuous operating points.

- Max. permissible discharge end temperature: 140°C
- Max. permissible ambient temperature: 100°C
- Max. permissible switching frequency: 12 x /h
- A minimum running time of 2 min. at equilibrium (continuous operation) must be achieved.

Avoid continuous operation near the threshold. Should the compressor happen to be used near the thresholds, we recommend the use of a thermal protection thermostat (Accessories, Chap. 7).

For operation with capacity regulator:

- Continuous operation, when the capacity regulator is activated, is not permissible and can cause damage to the compressor.
- The suction gas superheat temperature may need to be reduced or set individually when operating near to the threshold.
- When the capacity regulator is activated, the gas velocity in the system can not under certain circumstances ensure that sufficient oil is transported back to the compressor.

When operating in the vacuum range, there is a danger of air entering on the suction side. This can cause chemical reactions, a pressure rise in the condenser and an elevated compressed-gas temperature. Prevent the ingress of air at all costs!

3| Areas of application

3.4 N and K versions

Models available:

- FXK50/460 N • FXK50/555 N • FXK50/660 N • FXK50/775 N
- FXK50/460 K • FXK50/555 K • FXK50/660 K • FXK50/775 K

- FXK50/830 N • FXK50/980 N
- FXK50/830 K • FXK50/980 K

3.4.1 Limits of application R134a (N and K versions)

Permissible rotation speeds:

N Design: 500–3000 rpm (max rotation speed 3500 rpm)

K Design: 500–3500 rpm

Max. permissible operating pressure (g) high-pressure side (HP): 28 bar

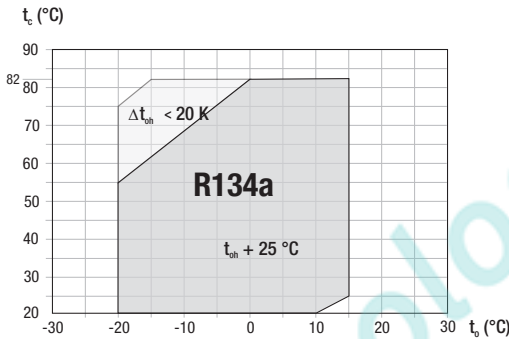

- Unrestricted application range
- Reduced suction gas temperature

- t_o Evaporation temperature (°C)
- t_c Condensing temperature (°C)
- Δt_{oh} Suction gas superheat (K)
- t_{oh} Suction gas temperature (°C)

Fig. 4

3.4.2 Limits of application R407C (N and K versions)

Permissible rotation speeds:

N Design: 500–2600 rpm

K Design: 500–3500 rpm

Max. permissible operating pressure (g) high-pressure side (HP): 28 bar

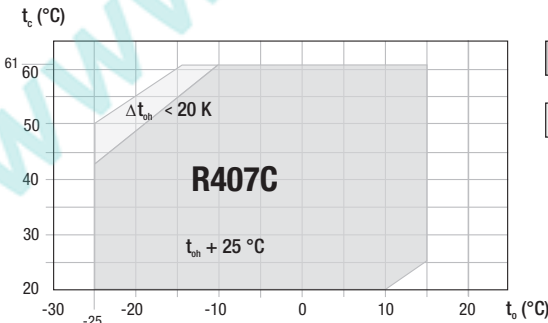

- Unrestricted application range
- Reduced suction gas temperature

- t_o Evaporation temperature (°C)
- t_c Condensing temperature (°C)
- Δt_{oh} Suction gas superheat (K)
- t_{oh} Suction gas temperature (°C)

Fig. 5

Design for other ranges on request

3| Areas of application

3.5 TK version

Models available:

- FK50/460 TK • FK50/555 TK • FK50/660 TK • FK50/775 TK
- FKX50/460 TK • FKX50/555 TK • FKX50/660 TK • FKX50/775 TK

3.5.1 Limits of application R404A/R507 (TK version)

Permissible rotation speeds:

TK design: 500–2600 rpm

Max. permissible operating pressure (g) high-pressure side (HP): 28 bar

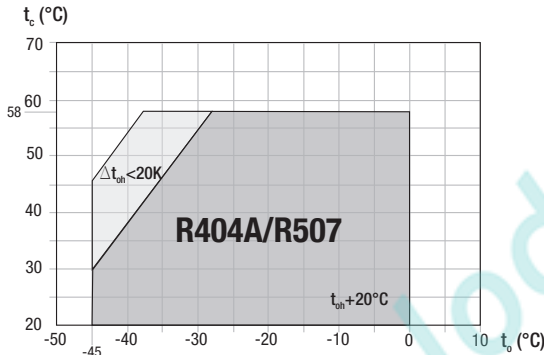

- Unrestricted application range
- Reduced suction gas temperature
- t_o Evaporation temperature (°C)
- t_c Condensing temperature (°C)
- Δt_{oh} Suction gas superheat (K)
- t_{oh} Suction gas temperature (°C)

Fig. 6

3.5.2 Limits of application R22 (TK version)

Permissible rotation speeds:

TK design: 500–2600 rpm

Max. permissible operating pressure (g) high-pressure side (HP): 28 bar

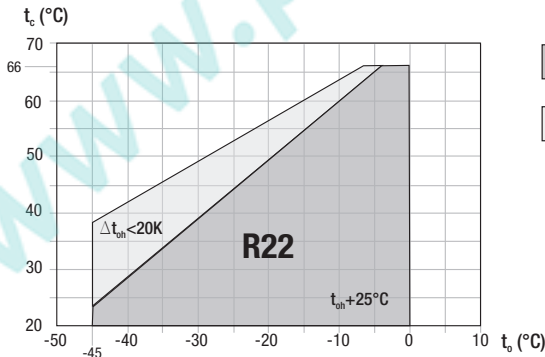

- Unrestricted application range
- Reduced suction gas temperature
- t_o Evaporation temperature (°C)
- t_c Condensing temperature (°C)
- Δt_{oh} Suction gas superheat (K)
- t_{oh} Suction gas temperature (°C)

Fig. 7

Design for other ranges on request

4| Compressor assembly



INFO

New compressors are factory-filled with inert gas. Leave this service charge in the compressor for as long as possible and prevent the ingress of air.
Check the compressor for transport damage before starting any work.

4.1 Setting up



WARNING

Move compressors only with hoists that have adequate load-bearing capacity.

- Transport and suspension unit on both eyebolts (Fig. 8).

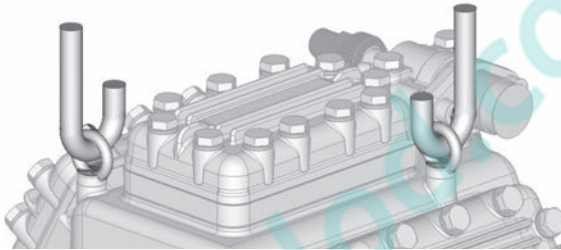

Fig. 8

- Fittings (e.g. pipe holders, additional units etc.) on the compressor are permissible only following consultation with GEA.
- Setup on an even surface or frame with sufficient load-bearing capacity. Use all 4 fastening points.
- Correct setup of the compressor and mounting of the belt drive are decisive for running comfort, operating safety and the service life of the compressor.

GB

4.2 Maximum permissible inclination



ATTENTION Poor lubrication can damage the compressor. Respect the stated values.

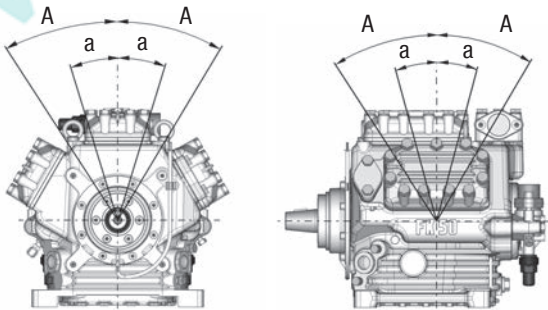

Fig. 9

A	max. 30°, max. 2 minutes
a	max. 15°, continuous operation

4| Compressor assembly

4.3 V-belt drive



ATTENTION Inappropriately designed belt drives, especially belt knocking or excessive tensioning forces can cause compressor damage! Make sure that the drive belt is designed correctly, e.g. by using tensioners and selecting the belt profile and the belt length.

- During operation with capacity controllers (Accessories, Chap. 7), the changing load can cause increased running noises and belt drive vibrations.

4.4 Main bearing load

To prevent the belt drive overloading the compressor main bearing, ensure that:

- The engagement force applied by the belt tension (centre of shaft taper, see Fig. 10) must not exceed $F_{\max \text{ per.}} = 2750 \text{ N}$.
- If the force engagement point shifts to the right (see Fig.10, small point), the force $F_{\max \text{ per.}}$ reduces as per the following formula:

$$F_{\max \text{ per.}} = \frac{245 \text{ kNmm}}{(90 \text{ mm} + L_1 [\text{mm}])}$$

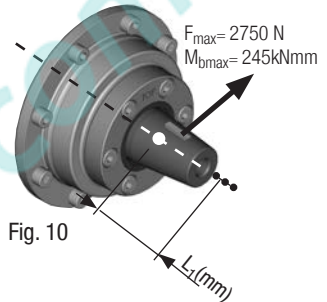

Fig. 10

4.5 Electromagnetic clutch assembly

The following description applies for an electromagnetic clutch secured to a shaft.

- To absorb the magnetic field of the electromagnetic clutch, the front bearing flange has a snug fit 148 h8 (see Fig. 11).
- To connect the magnetic field, loosen the 4 cheese head screws M8 on the bearing flange (see Fig. 11).
- Slide the magnetic field to a snug fit and re-attach using the four cheese head screws M8 (Fig. 12). Screw torque = 37 Nm.
- Further assembly of the electromagnetic clutch according to the clutch manufacturer.

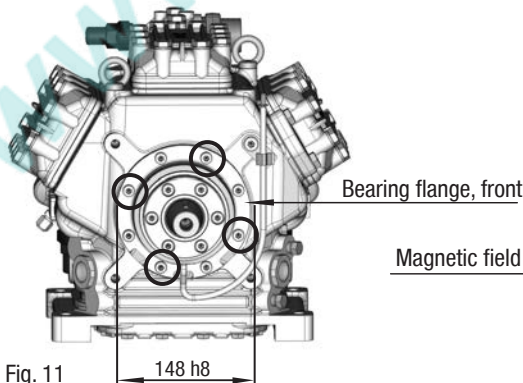

Fig. 11

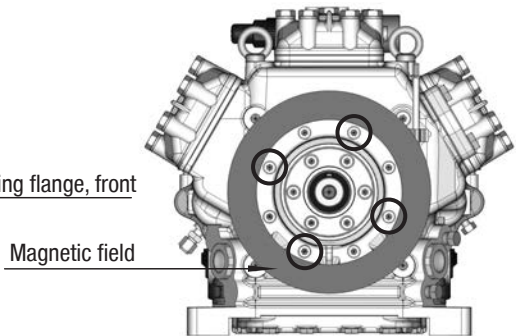

Fig. 12

4| Compressor assembly

4.6 Pipe connections

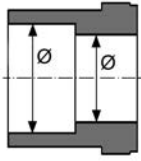

Fig. 13: Stepped internal diameters

- The **discharge and suction line valves** have stepped internal diameters, enabling the use of pipes with standard millimetre and inch dimensions. The depth of pipe insertion will depend on the dimension.
- The connection diameters of the shut-off valves are designed for maximum compressor output. **The required pipe cross-section must be matched to the capacity. The same applies for non-return valves.**



ATTENTION Overheating can damage the valve. Therefore, remove the pipe supports from the valve before soldering. Solder only using inert gas to inhibit oxidation products (scale).

- The required tightening torque for the flange connection is 60 Nm.

4.7 Pipes

- Pipes and system components must be clean and dry inside and free of scale, swarf and layers of rust and phosphate. Only use air-tight parts.
- Lay pipes correctly. Suitable vibration compensators must be provided to prevent pipes being cracked and broken by severe vibrations.
- Ensure a proper oil return.
- Keep pressure losses to an absolute minimum.

4.8 Operating the shut-off valves

- Before opening or closing the shut-off valve, release the valve spindle seal by approx. $\frac{1}{4}$ of a turn counter-clockwise.
- After activating the shut-off valve, re-tighten the adjustable valve spindle seal clockwise.

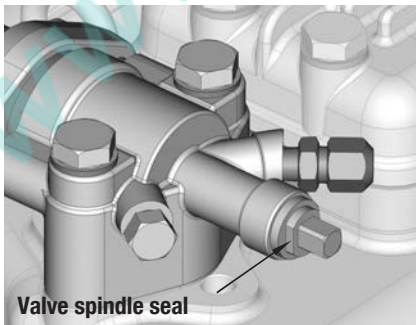

Fig. 14

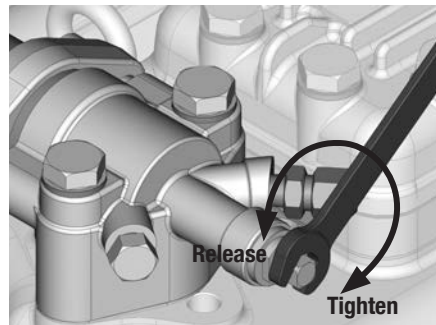

Fig. 15

4| Compressor assembly

4.9 Operating mode of the lockable service connections

Opening the shut-off valve

Spindle 1: turn to the left (counter-clockwise) as far as it will go.

—> Shut-off valve fully opened / service connection 2 closed.

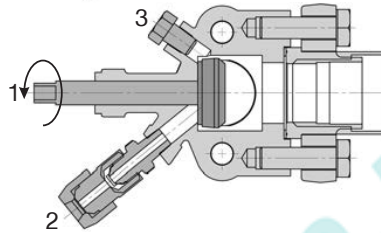

Fig. 16

Opening the service connection (2):

Spindle 1: $\frac{1}{2}$ - 1 rotation to the right
—> Service connection 2 opened / shut-off valve closed.

Connection 3 is provided for safety devices and is not lockable.

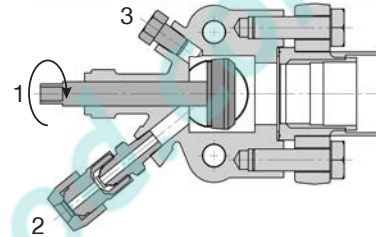

Fig. 17

After activating the spindle, generally fit the spindle protection cap again and tighten with 14-16 Nm. This serves as a second sealing feature during operation.

4.10 Suction pipe filter

For systems with long pipes and higher degree of contamination, a filter on the suction-side is recommended. The filter has to be renewed depending on the degree of contamination (reduced pressure loss).

5| Commissioning

5.1 Preparations for start-up



INFO

To protect the compressor against inadmissible operating conditions, high-pressure and low-pressure pressostats are mandatory on the installation side.

The compressor has undergone trials in the factory and all functions have been tested. There are therefore no special running-in instructions.

Check the compressor for transport damage!

5.2 Pressure strength test

The compressor has been tested in the factory for pressure integrity. If however the entire system is to be subjected to a pressure integrity test, this should be carried out in accordance with EN 378-2 or a corresponding safety standard **without the inclusion of the compressor.**

5.3 Leak test



DANGER

Risk of bursting!

The compressor must only be pressurised using nitrogen (N₂). Never pressurise with oxygen or other gases!

The maximum permissible overpressure of the compressor must not be exceeded at any time during the testing process (see name plate data)! Do not mix any refrigerant with the nitrogen as this could cause the ignition limit to shift into the critical range.

- Carry out the leak test on the refrigerating plant in accordance with EN 378-2 or a corresponding safety standard, while always observing the maximum permissible overpressure for the compressor.

5.4 Evacuation

- First **evacuate the system** and then include **the compressor in the evacuation process.**
- **Relieve the compressor pressure.**
- Open the suction and discharge line valves.
- Evacuate the suction and discharge pressure sides using the vacuum pump.
- At the end of the evacuation process, the vacuum should be < 1.5 mbar when the pump is switched off.
- Repeat the process as often as is required.

GB

5| Commissioning

5.5 Refrigerant charge



CAUTION

Wear personal protective clothing such as goggles and protective gloves!



ATTENTION

- **Avoid overfilling the system with refrigerant!**
- **To avoid shifts in concentration, zeotropic refrigerant blends must always be added to the refrigerating plant in liquid form.**
- **Do not pour liquid refrigerant through the suction line valve on the compressor.**
- **It is not permissible to mix additives with the oil and refrigerant.**

- Make sure that the suction and discharge line valves are open.
- With the compressor switched off, add the liquid refrigerant directly to the condenser or receiver, breaking the vacuum.
- If the refrigerant needs topping up after starting the compressor, it can be topped up in vapour form on the suction side, or, taking suitable precautions, also in liquid form at the inlet to the evaporator.

GB

5.6 Oil level check

After starting, check the compressor's oil level.

- Drive motor in operating condition "High idle".
- Compressor run time min. 10 minutes.
- The system should have reached operating points.
- Check oil level. As the installation location of the compressor can differ in practice (inclinations), it is recommended that the oil level is checked in both sightglasses. The oil level must be visible in at least one sightglass.



ATTENTION

After a compressor is replaced, the oil level must be checked again. If the level is too high, oil must be drained off (risk of oil impact, reduced performance of the air-conditioning system).

5.7 Shaft seal



ATTENTION

Failure to observe the following instructions can cause loss of refrigerant and damage to the shaft seal!



INFO

- **The shaft seal seals and lubricates with oil. An oil leakage of 0.05 ml per operating hour is therefore normal. This applies particularly during the run-in phase (200 - 300 h).**
- **To trap and collect leaked oil, the FK50 is fitted with an integrated leak oil trapping device with oil reservoir (P.6, Fig. 1).**

5| Commissioning

The compressor shaft is sealed to outside using a shaft seal. The sealing element rotates with the shaft.

The following is especially important to ensuring fault-free operation:

- The complete refrigerant circuit must be correctly executed and clean inside.
- Heavy shocks and vibrations to the shaft as well as continuous cyclic operation are to be avoided.
- The sealing surfaces can stick together during prolonged downtimes (e.g. winter). Therefore, run the system every 4 weeks for 10 minutes.

5.8 Avoiding liquid shocks



ATTENTION Slugging can damage the compressor and cause refrigerant to leak.

To prevent liquid shocks:

- The complete refrigeration plant must be correctly designed and executed.
- The capacities of all components must be compatible (particularly evaporator and expansion valve).
- Suction gas superheating at the evaporator output should be at least 7 – 10 K (check setting of the expansion valve).
- The system must reach a state of equilibrium.
- Particularly in critical systems (e.g. several evaporator points), suitable measures, e.g. use of liquid traps, solenoid valve in the liquid line, etc. are recommended.

GB

6| Maintenance

6.1 Preparation



WARNING

Before starting any work on the compressor:

- Switch off the compressor and secure it to prevent a restart.
- Relieve compressor of system pressure.
- Prevent air from infiltrating the system!

After maintenance has been performed:

- Connect safety switch.
- Evacuate compressor.
- Release switch lock.

6.2 Work to be carried out

- **Oil change:** In principle, an oil change is not mandatory if the system is correctly manufactured and operated. However, based on decades of experience we recommend that the following oil change/service work is carried out:
 - First oil change during the first maintenance of the vehicle.
 - Then after every 5,000 operating hours, though no more than 3 years, clean the oil strainer at the same time. If necessary, also empty the oil reservoir at the shaft seal.
- **Annual checks:** Oil level, tightness of the compressor, running noise, pressures, temperatures, function of auxiliary devices such as checking the capacity control.

6.3 Shaft seal, emptying the oil reservoir

As changing the shaft seal involves opening the refrigerant circuit, this is recommended only if the seal is losing refrigerant. Replacing the shaft seal is described in the spare part kit concerned.

Emptying the oil reservoir: The oil reservoir can be emptied very simple without having to dismantle the clutch and/or belt drive. It is recommended that this is done at the same time as the air-conditioning maintenance and motor service.

To proceed, detach the oil hose from the bracket, remove the plug and drain the oil into a collecting vessel. After emptying, reseal the oil hose and clamp it into the bracket.

Dispose of the used oil in accordance with national regulations.

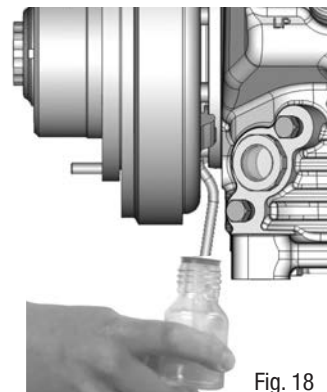

Fig. 18

6| Maintenance

6.4 Recommended spare parts

FK50 / ...	460 N, TK 555 N, TK	660 N, TK 775 N, TK 830 N 980 N	460 K, 555 K 660 K, 775 K 830 K, 980 K
Designation	Art. No.	Art. No.	Art. No.
Set of gaskets	80231		80089
Valve plate kit	80243	80244	08926
Set of shaft seals	80023		
Oil SP 46, 1 litre	02279		
Oil SE 55, 1 litre	02282		

Only use genuine GEA spare parts!

6.5 Integrated decompression valves

The valves are fundamentally maintenance-free.

However, constant leakage can occur after repeated blowing off due to abnormal operating conditions. This leads to reduced performance and increases the compressed gas temperature. In this case check the valves and replace as necessary.

GB

6.6 Extract from the lubricants table

The oil type charged as standard in the factory is marked on the **name plate**. **This oil type should be used as a preference.** Alternatives are stated in the extract from our lubricants table below.

Refrigerants	GEA standard oil types	Recommended alternatives
HFC (e.g. R134a, R407, R 404A)	Fuchs Reniso Triton SE 55 (see also chap. 6.3)	Fuchs SEZ 32/68/80 Esso/Mobil EAL Arctic 46
HCFC (e.g. R22)	Fuchs Reniso SP 46 (see also chap. 6.3)	BP Energol LPT 46 Sunoco Suniso 3.5GS Texaco Capella WF 46

6.7 Decommissioning

Close the shut-off valve on the compressor. Drain the refrigerant (it must not be discharged directly into the environment) and dispose of it according to the regulations. When the compressor is depressurised, undo the fastening screws of the shut-off valves. Remove the compressor using an appropriate hoist. Dispose of the oil inside in accordance with the valid national regulations.

7 | Accessories

7.1 Capacity regulation



ATTENTION

- **Capacity-regulated operation alters the gas speeds and pressure ratios of the refrigerating plant: Adjust the suction line routing and dimensioning accordingly, do not set the control intervals too close and do not let the system switch more than 12 times per hour (refrigerating plant must have reached a state of equilibrium). Continuous operation in the control stage is not recommended as the gas velocity in the plant system under certain circumstances does not guarantee sufficient oil return to the compressor with activated capacity regulator for a compressor speed below 1200 - 1500 rpm. We recommend switching to unregulated operation (100% capacity) for at least 5 minutes per capacity-regulated operating hour. An assured oil return can also be realised by a 100% capacity requirement after each compressor restart as otherwise the compressor can also be shut down in the regulated operating time by the thermostat.**
- **Electrical actuation of the solenoid valve: Normally open, (corresponds to 100 % compressor capacity).**
- **Cylinder covers for capacity regulation are marked with the designation "CR" (Capacity Regulator).**

FK50 / N + TK	... K
Designation	Item No.	Item No.
Special accessory 12 V	08703	08708
Special accessory 24 V	08704	08709

For a description, see technical information "Capacity regulation" (Item No. 09900)

If the capacity regulator is factory-fitted, it is integrated into an extra, dedicated cylinder cover. For retrofits, it is supplied with the cylinder cover. The regulator closes one cylinder bank at a time (capacity regulation approx. 33 %). Two retrofit kits are required for a capacity regulation of approx. 66 %.

7.2 Thermal protection thermostat (Item No. 07595)

A screw-in option is provided for the sensor element on the hot gas side of the compressor housing (see Chap. 9). Connect the thermal protection thermostat in series with the control line.

Technical Data:

- Switching voltage max. : 24 V DC
- Switching current max. : 2.5 A at 24 V DC
- Switch-off temperature : 145 °C ± 5 K
- Switch-on temperature : approx. 115 °C

8| Technical data

Type	No. of cylinders	Displacement cm ³	Swept volume (1450 rpm) m ³ /h	Weight kg	Connections		Oil charge Ltr.	Inertia moment of the driving unit [kgm ²]	Lubrication	Oil pump
					Discharge line DV mm / inch	Suction line SV mm / inch				
FK50/460	6	459	40,1	44,0	28 / 1 1/8	35 / 1 3/8	2,5	0,0047	Forced lubrication	Rotation direction independent
FK50/555		556	48,3	43,0	28 / 1 1/8	35 / 1 3/8				
FK50/660		662	57,6	42,0	35 / 1 3/8	2 x 35 / 1 3/8				
FK50/775		776	67,6	41,0	35 / 1 3/8	2 x 35 / 1 3/8	0,0056			
FK50/830		831	72,3	43,0	35 / 1 3/8	2 x 35 / 1 3/8				
FK50/980		976	84,9	41,0	35 / 1 3/8	2 x 35 / 1 3/8				

The technical data for the different designs K, N and TK are identical.
The compressor type data therefore do not mention these additions.

9| Dimensions and connections

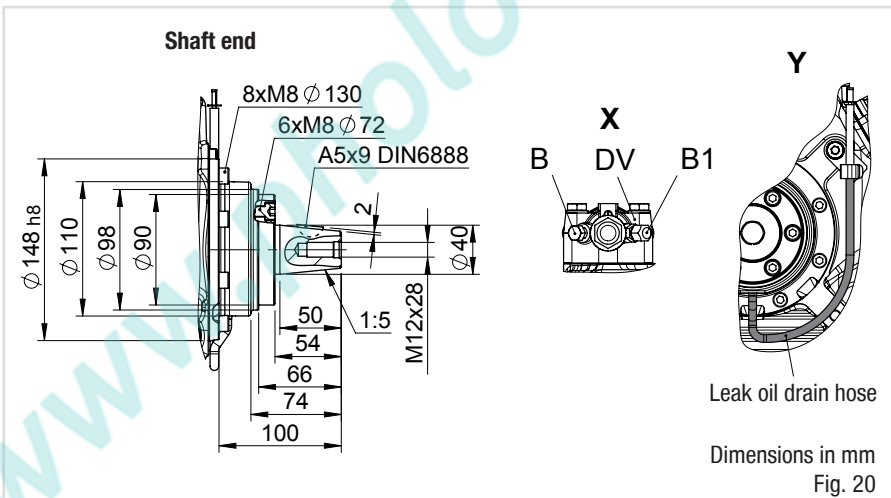
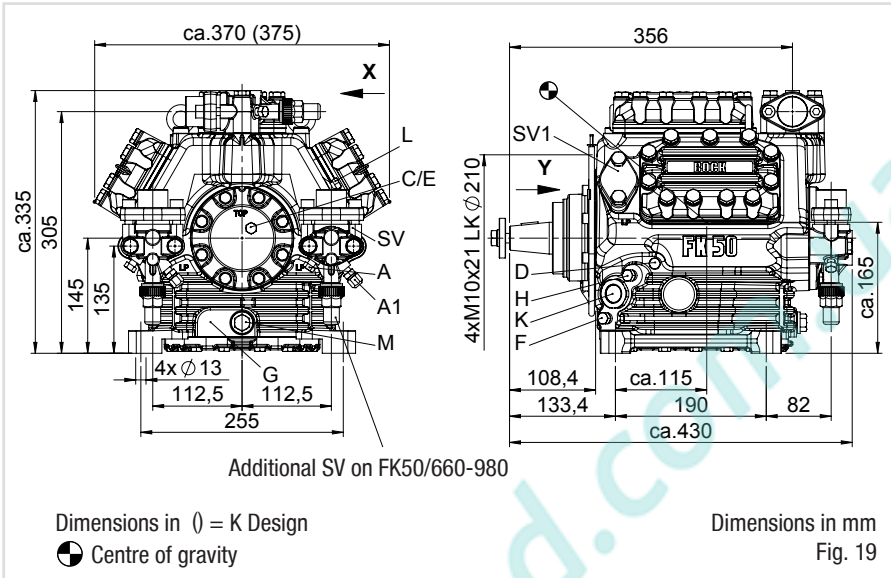

GB

9| Dimensions and connections

SV	Suction line	see technical data, Chapter 8	
DV	Discharge line		
A	Connection suction side, not lockable		1/8" NPTF
A1	Connection suction side, lockable		7/16" UNF
B	Connection discharge side, not lockable		1/8" NPTF
B1	Connection discharge side, lockable		7/16" UNF
C	Connection oil pressure safety switch OIL		1/8" NPTF
D	Connection oil pressure safety switch LP		1/8" NPTF
E	Connection oil pressure gauge		1/8" NPTF
F	Oil drain		1/4" NPTF
G	Opt. connection for oil sump heater		1)
H	Oil charge plug		1/4" NPTF
K	Sight glass		2 x 1 1/8" - 18 UNEF
L	Connection thermal protection thermostat		1/8" NPTF
M	Oil strainer		M22 x 1.5
SV1	Opt. connection for suction line valve		- -

¹⁾ No connection available as standard.
Available on request (Connection M22 x 1.5)

GB

10| Installation certificate

INSTALLATION CERTIFICATE

for using the compressors within the European Union
(in accordance with Machinery Directive 2006/42/EC)

The manufacturer: GEA Bock GmbH, Benzstraße 7
D-72636 Frickenhausen, Tel.: 07022/9454-0

hereby declares that the refrigerating compressor **FK50** conforms to the essential requirements of Annex II 1B of the Machinery Directive 2006/42/EC.

Applied harmonised standard:

EN 12693:2008 and the corresponding standards referenced

A partly completed machine may only be put into operation when it has been established that the machine, into which the partly completed machine is to be installed, conforms to the regulations of the Machinery Directive (2006/42/EC).

The manufacturer undertakes to transmit electronically the special documentation required by individual states for partly completed machinery upon request.

The special technical documentation required for partly completed machinery has been created in accordance with Annex VII Part B.

Person responsible for documentation is:
Wolfgang Sandkötter, Benzstraße 7, 72636 Frickenhausen.

Frickenhausen, 01.11.2011



ppa. Wolfgang Sandkötter,
Chief Development Officer

11| Service

Dear customer,

GEA compressors are top-quality, reliable and service-friendly quality products.

If you have any questions about installation, operation and accessories, please contact our technical service or specialist wholesaler and/or our representative. The GEA service team can be contacted by phone with a **toll-free hotline 00 800 / 800 000 88** or via **e-mail:**

info@gea.com

Yours faithfully

GEA Bock GmbH

Benzstraße 7

72636 Frickenhausen

Germany

GB



We live our values.

Excellence • Passion • Integrity • Responsibility • GEA-versity

GEA Group is a global engineering company with multi-billion euro sales and operations in more than 50 countries. Founded in 1881, the company is one of the largest providers of innovative equipment and process technology. GEA Group is listed in the STOXX® Europe 600 index.