

SC12/12CL LBP/MBP Twin Compressor R404A/R507 220-240V 50Hz

General

Code number	104L4088
Approvals	EN 60335-2-34
Compressors on pallet	18

Application

Application	LBP/MBP		
Frequency	Hz	50	60
Evaporating temperature	°C	-45 to -5	-
Voltage range	V	198 - 254	-
Max. condensing temperature continuous (short)	°C	55 (60)	-
Max. winding temperature continuous (short)	°C	125 (135)	-

Cooling requirements

Frequency	Hz	50			60		
Application		LBP	MBP	HBP	LBP	MBP	HBP
32°C		F ₂	F ₂	-	-	-	-
38°C		F ₂	F ₂	-	-	-	-
43°C		-	-	-	-	-	-
Remarks on application:							

Motor

Motor type	CSIR		
LRA (rated after 4 sec. UL984) *, HST LST	A	2 x 14.8	-
Cut in Current *, HST LST	A	2 x 14.8	-
Resistance, main start winding (25°C)	Ω	5.0	13.7

* Operational current for the second compressor time-delayed.

Design

Displacement	cm ³	2 x 12.87
Oil quantity (type)	cm ³	1220 (polyolester)
Maximum refrigerant charge	g	2200
Free gas volume in compressor	cm ³	2820
Weight without electrical equipment	kg	27.3

Dimensions

Height	mm	A	249
		B	244
		B1	183
		B2	100
Suction connector (service valve)	location/I.D. mm	C	12 37°
Suction connector (solder connector)	location/I.D. mm	C	12 37°
Process connector	location/I.D. mm angle	D	6.2 37°
	material comment		Cu-plated steel Al cap
Discharge connector	location/I.D. mm angle	E	6.2 37°
	material comment		Cu-plated steel Al cap
Oil cooler connector	location/I.D. mm angle	F	-
	material comment		-
Connector tolerance	I.D. mm		±0.09
Remarks:			

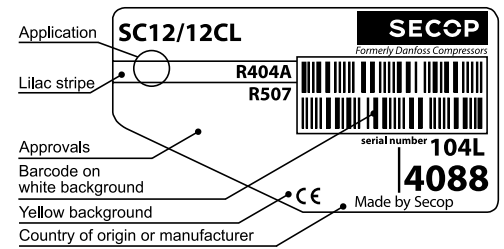

- S = Static cooling normally sufficient
- O = Oil cooling
- F₁ = Fan cooling 1.5 m/s (compressor compartment temperature equal to ambient temperature)
- F₂ = Fan cooling 3.0 m/s necessary
- SG = Suction gas cooling normally sufficient
- = not applicable in this area

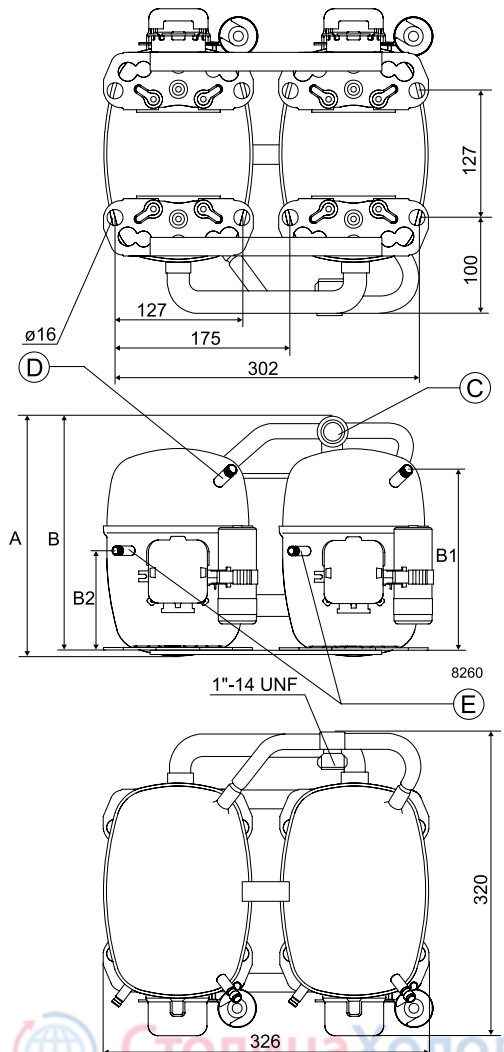

EN 12900 Household (CECOMAF)* 220V, 50Hz, fan cooling F₂

Evap. temp. in °C	-45	-40	-35	-30	-25	-23.3	-20	-15	-10	-6.7	-5	0	5	7.2	10	15	20
Capacity in W	115	279	475	706	980	1083	1299	1670	2096	2411	2583						
Power cons. in W	379	506	633	761	891	936	1024	1163	1308	1407	1460						
Current cons. in A	4.30	4.55	4.85	5.22	5.64	5.80	6.13	6.67	7.27	7.71	7.94						
COP in W/W	0.30	0.55	0.75	0.93	1.10	1.16	1.27	1.44	1.60	1.71	1.77						

ASHRAE LBP/MBP 220V, 50Hz, fan cooling F₂

Evap. temp. in °C	-45	-40	-35	-30	-25	-23.3	-20	-15	-10	-6.7	-5	0	5	7.2	10	15	20
Capacity in W	134	323	550	819	1137	1257	1509	1941	2440	2796	3011						
Power cons. in W	379	506	633	761	891	936	1024	1163	1308	1407	1460						
Current cons. in A	4.30	4.55	4.85	5.22	5.64	5.80	6.13	6.67	7.27	7.71	7.94						
COP in W/W	0.35	0.64	0.87	1.08	1.28	1.34	1.47	1.67	1.87	1.99	2.06						

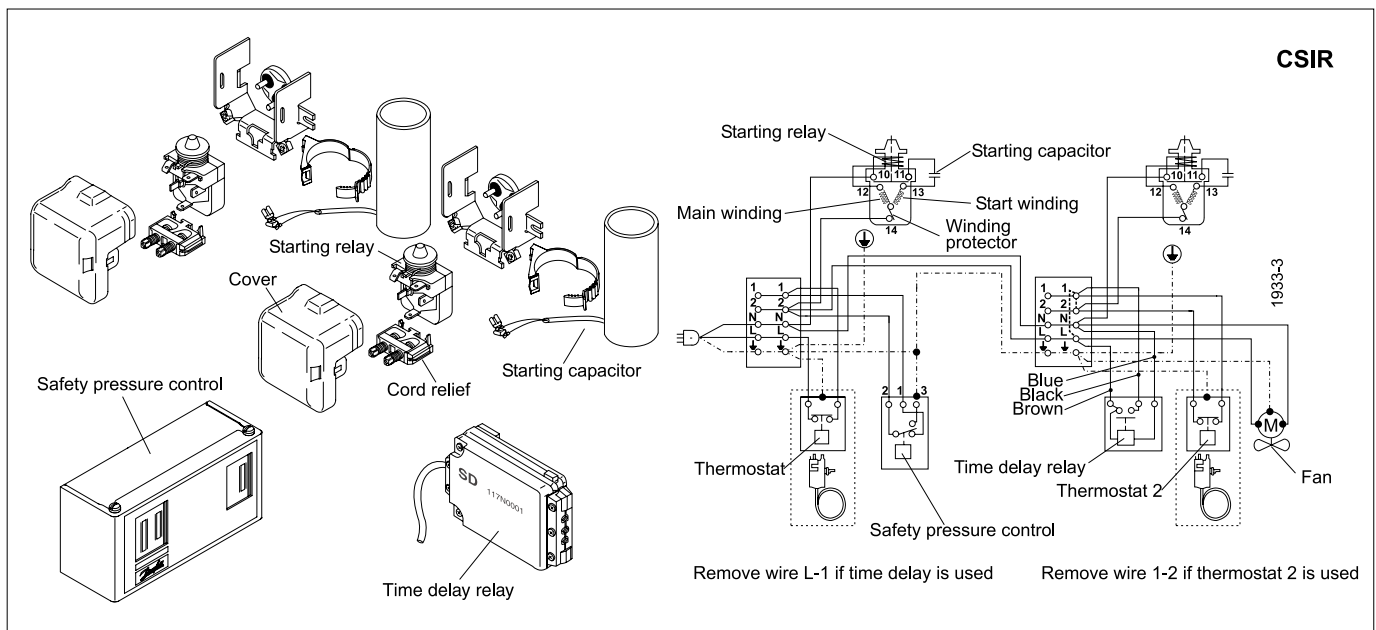

Accessories	SC12/12CL	pcs.	Code number
Starting device	470 mm cable length	2	-
	550 mm cable length		-
	650 mm cable length		-
Starting relay	6.3 mm spade connectors	2	117U6005
Start. capacitor 80 µF	6.3 mm spade connectors	2	117U5017
Cover		2	103N2009
Cord relief		2	103N1004
Time-delay relay		1	117N0001
Check valve (to be used with time-delay relay)		2	020-1014
Service valve	12 mm	1	118-7350
Solder connector (alternative)	12 mm	1	104B0584
Service valve	16 mm	1	-
Solder connector (alternative)	16 mm	1	-
Seal ring for service valve and solder connector		1	118-3638

Test conditions	EN 12900/CECOMAF*	ASHRAE LBP/MBP
Condensing temperature	45°C	45°C
Ambient temperature	32°C	32°C
Suction gas temperature	32°C	32°C
Liquid temperature	no subcooling	32°C

Mounting accessories		pcs.	Code number
Bolt joint for one compressor	Ø: 16 mm	2	118-1917
Bolt joint in quantities	Ø: 16 mm	2	118-1918

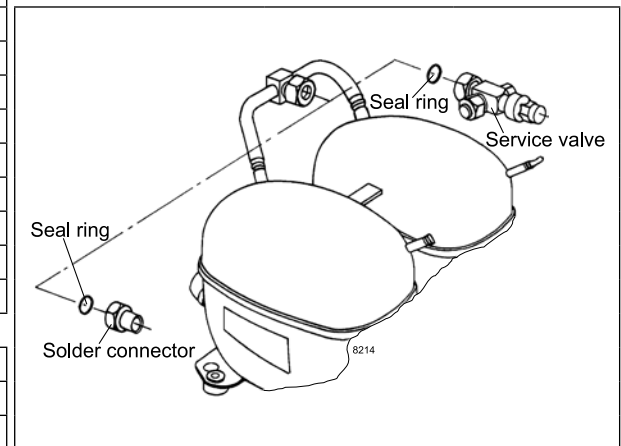

Danfoss can accept no responsibility for possible errors in catalogues, brochures and other printed material. Danfoss reserves the right to alter its products without notice. This also applies to products already on order provided that such alterations can be made without subsequential changes being necessary in specifications already agreed. All trademarks in this material are property of the respective companies. Danfoss and the Danfoss logotype are trademarks of Danfoss A/S. All rights reserved.