

# SC12/12G Universal Twin Compressor R134a 220-240V 50Hz

Data Sheet (Replaces CD.44.F6.02)

## General

Compressor	SC12/12G
Code number	104G8280

## Application

Application		LBP/HBP
Evaporating temperature range	°C	-35 to 15
Voltage range	V/Hz	198 - 254 / 50
Motor type		CSIR
Max. ambient temperature	°C	43
Comp. cooling at ambient temp.	32°C	LBP: F <sub>2</sub>
		HBP: F <sub>2</sub>
	38°C	LBP: F <sub>2</sub>
		HBP: F <sub>2</sub>
43°C	LBP: F <sub>2</sub>	
	HBP: F <sub>2</sub>	

## Design

Displacement	cm <sup>3</sup>	2 x 12.87
Oil quantity	cm <sup>3</sup>	1120
Maximum refrigerant charge	g	2200
Free gas vol. in compressor	cm <sup>3</sup>	3020
Weight without electrical equipment	kg	28

## Motor

Motor size	watt	2 x 315
LRA (rated after 4 sec. UL984) HST*	A	12.6
Cut-in current HST*	A	12.6
Resistance, main and start winding (25°C)	Ω	6.7/11.8
Approvals		EN 60335-2-34

\* Operational current for the second compressor time-delayed.

## Dimensions

Height	mm	A	249
		B	244
		B1	183
		B2	100
Suction connector	location/I.D. mm	C	12
		Solder connector	12
Process connector	location/I.D. mm	D	6.2 ±0.09
Discharge connector	location/I.D. mm	E	6.2 ±0.09
Compressors on a pallet	pcs.		18

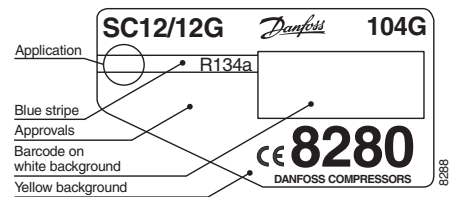

- S = Static cooling normally sufficient
- O = Oil cooling
- F<sub>1</sub> = Fan cooling 1.5 m/s  
(compressor compartment temperature equal to ambient temperature)
- F<sub>2</sub> = Fan cooling 3.0 m/s necessary

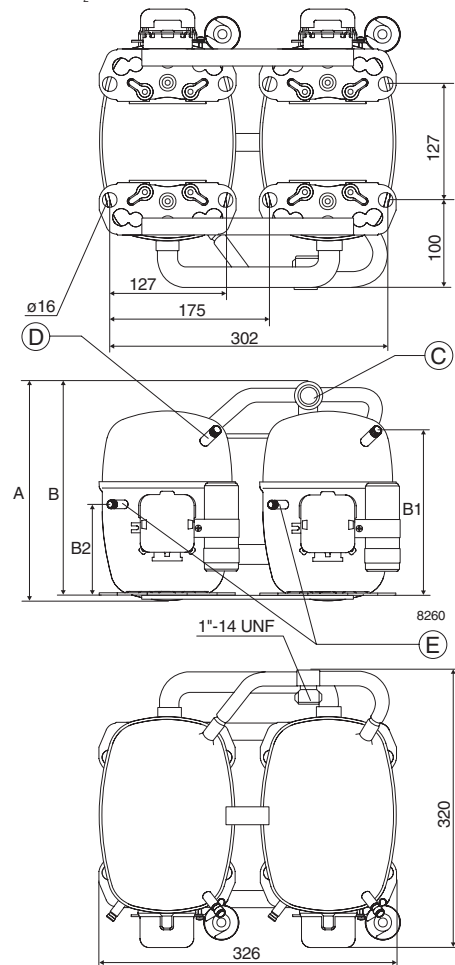

**Capacity (EN 12900/CECOMAF)**

Comp.\°C	-35	-30	-25	-23.3	-20	-15	-10	-5	0	5	7.2	10	15
SC12/12G	129	226	350	399	505	696	928	1206	1535	1920	2108	2364	2875

**watt**
**Capacity (ASHRAE)**

Comp.\°C	-35	-30	-25	-23.3	-20	-15	-10	-5	0	5	7.2	10	15
SC12/12G	159	279	432	492	623	860	1147	1493	1902	2382	2617	2939	3580

**watt**
**Power consumption**

Comp.\°C	-35	-30	-25	-23.3	-20	-15	-10	-5	0	5	7.2	10	15
SC12/12G	296	373	454	481	537	622	710	800	892	986	1028	1081	1177

**watt**
**Current consumption**

Comp.\°C	-35	-30	-25	-23.3	-20	-15	-10	-5	0	5	7.2	10	15
SC12/12G	3.25	3.44	3.66	3.74	3.90	4.17	4.47	4.79	5.14	5.52	5.69	5.92	6.35

**A**
**COP (EN 12900/CECOMAF)**

Comp.\°C	-35	-30	-25	-23.3	-20	-15	-10	-5	0	5	7.2	10	15
SC12/12G	0.44	0.61	0.77	0.83	0.94	1.12	1.31	1.51	1.72	1.95	2.05	2.19	2.44

**W/W**
**COP (ASHRAE)**

Comp.\°C	-35	-30	-25	-23.3	-20	-15	-10	-5	0	5	7.2	10	15
SC12/12G	0.54	0.75	0.95	1.02	1.16	1.38	1.62	1.87	2.13	2.42	2.55	2.72	3.04

**W/W**

Test conditions	EN 12900/CECOMAF	ASHRAE
Condensing temperature	55°C	55°C
Ambient and suction gas temp.	32°C	32°C
Liquid temperature	55°C	32°C
Fan cooling $F_2$ , 220V 50Hz		

**Accessories**

Devices	pcs.	SC12/12G
Starting relay	2	117U6003
Starting capacitor 80 $\mu$ F	2	117U5017
Cover	2	103N2009
Cord relief	2	103N1004
Time-delay relay	1	117N0001
Check valve (to be used with time-delay relay)	2	020-1014
Service valve	1	118-7350 (12 mm)
Solder connector (alternative)	1	104B0584 (12 mm)
Seal ring for service valve and solder connector	1	118-3638
Mounting accessories Bolt joint for one compressor Bolt joint in quantities	2	118-1917 118-1918

